

**Proceedings of the 19th International Symposium on the
Packaging and Transportation of Radioactive Materials**

PATRAM 2019

August 4-9, 2019, New Orleans, LA, USA

**1335 Emergency Preparedness for Spent Fuel Shipments during Loss of Cooling
Function in Ships**

Takeru KOGA, Tatsuya MINAMI

Safety & Security Design and Development Department, Nuclear Fuel Transport Co.,
Tokyo, Japan

ABSTRACT

Nuclear Fuel Transport Co., owns and manages a ship for spent fuel shipments from nuclear power plants to the reprocessing facility in Japan. She satisfies the requirements of Class INF 3 ship of IMO. She has cooling devices in her holds, because of spent fuel heat.

We have evaluated hazards of natural events related to nuclear material transport, one of the hazards is “loss of cooling function” in case the ship is grounded on land due to tsunami. This hazard may occur as a result of the cooling device stopping because of the inability to take on seawater by being grounded on land, however the probability of this hazard occurring is very low. We evaluated the hazard by the following process.

First, we evaluated the influence by analysis for this hazard assessment. In the assessment, we analysed under conditions maximum number (four) of the packages loaded in the hold and cooling devices stopped. As a result, it was shown that the seal of the packages could be broken after a certain period of time because of high design heat generation rate of the packages and conservative analysis model (not considering heat radiation from the side of the hold).

Next, we studied a mitigation measure to open all apertures from inside of the hold to outside directly. We changed the analysis model to be more realistic, and analysed by the model in consideration of the mitigation measure. As the result, we confirmed that the seal integrity could be maintained in case of up to two packages in the hold if the mitigation measure was carried out.

Furthermore, we conducted a parameter survey on the heat generation rate for maintaining the seal integrity in case of loading 3 or 4 packages in the hold, and we obtained acceptable heat generation rates.

Based on these results, we confirmed the seal integrity can be maintained at the “loss of cooling function” event by restricting the number of loaded packages in the hold or heat generation rate of the packages, and to take the mitigation measure as emergency preparedness.

INTRODUCTION

Nuclear Fuel Transport Co., owns and manages a ship for spent fuel shipments from nuclear power plants to the reprocessing facility in Japan. She satisfies the requirements of Class INF 3 ship of IMO. She has five holds and is able to load twenty packages which contain SF. She has cooling devices in her holds, because packages have high design heat generation rate.

The package which has the highest design heat generation rate loaded into the ship is NFT-14P type cask. This cask is able to hold 14 spent fuels for PWR which is 54kW¹ design heat generation rate (See Figure 1).

We have evaluated hazards of natural events related to nuclear material transport, one of the hazards is “loss of cooling function” in case the ship is grounded on land due to tsunami. This hazard may occur as a result of the cooling device stopping because of the inability to take on seawater by being grounded on land, however the probability of this hazard occurring is very low. We evaluated the hazard by the following process;

- (1) We have evaluated the influence by analysis for this hazard assessment. In the assessment, we analyzed by FLUENT which is thermal fluid dynamic code under conditions maximum number (four) of the packages loaded in the hold, heat insulation between the holds, and cooling devices stopped.
- (2) Based on the result of (1), we studied several mitigation measures and analyzed by FLUENT to consider one of the mitigation measures under the same conditions as the case (1) except the mitigation measure.
- (3) Based on the result of (2), we confirmed the mitigation measure’s effectiveness, so we conducted a parameter survey by FLUENT which parameters are the heat generation rate and number of packages loaded in the hold.

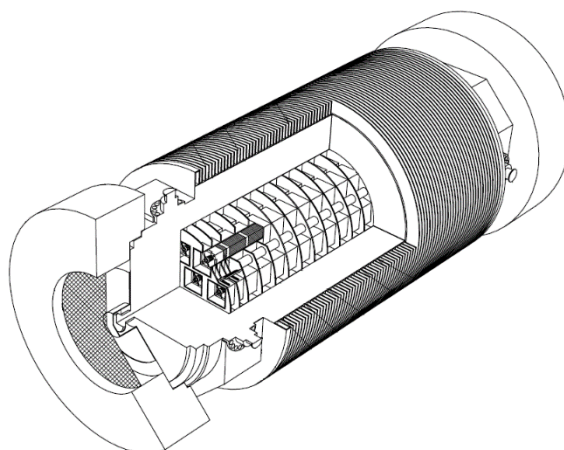

Figure 1. NFT-14P type package

¹ Because of the restriction from the reprocessing facility, spent fuels cooled for longer than 12 years (heat generation rate of the package is about 13kW) can be transported. Also, the maximum heat generation rate of the package transported in the past was about 43kW and the average was about 21kW.

DURATION OF SEAL INTEGRITY

After loss of cooling function, the temperature of packages in holds rises accompanying a pressure rise in the cavity of packages, which might result in the leak of cavity water to the hold and a severe accident following such as failure of fuel assemblies. In order to evaluate the period of time maintaining the seal integrity of packages after loss of cooling function, we conducted thermal fluid dynamic analysis by FLUENT code and the following thermal transfer analysis by ABAQUS code.

Under Cooling Device Operation

In order to evaluate temperature distribution in the hold at thermal equilibrium under cooling device operation, which would be given to the following analysis as an initial condition, thermal fluid dynamic analysis was conducted. Analysis condition is shown in figure 2. Details of the analysis conditions are shown below.

- (a) Analysis model of the hold including the maximum number (four) of packages was constructed in 2D.
- (b) Each of four packages in the hold has high design heat generation rate of 54kW.
- (c) Insulation condition was conservatively given to the walls between holds and the bottom surface of the hold.
- (d) Temperature in the hold is required to be under 38 degrees Celsius during transport according to Japanese regulation. Therefore, the ship has a cooling device, which provides air of 23 degrees Celsius. Flow rate of the air was coordinated to 0.35m/s in this analysis so that the temperature in the hold would be under 38 degrees Celsius and the temperature on the external surface of the package would correspond to 118 degrees Celsius, which was resulted from the assessment in Safety Analysis Report under normal conditions of transport without insulation.
- (e) Air convection in the hold was calculated by FLUENT code, and radiation between cask surfaces and hold inner surfaces including the interim hatch was considered as a form of thermal transfer.

Temperature distribution in the hold at thermal equilibrium under cooling device operation is shown in figure 3.

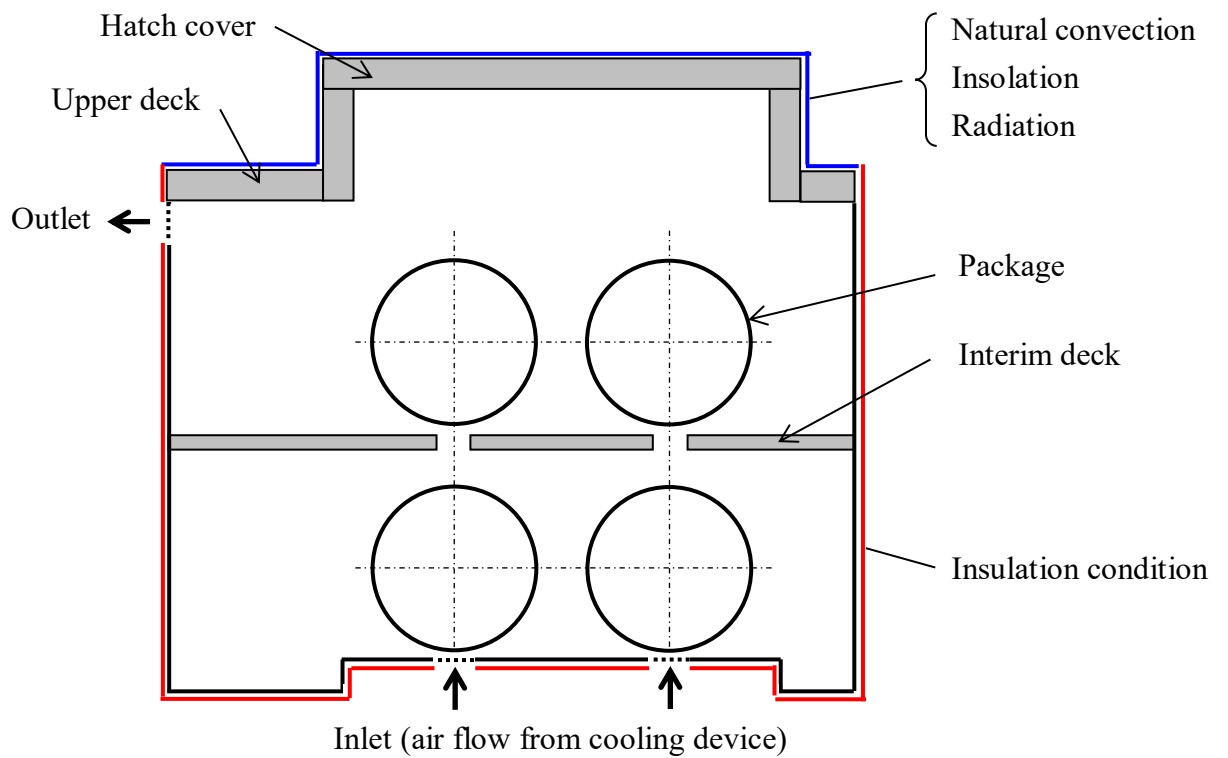

Note: The inlet and outlet surfaces are changed to insulation condition after loss of cooling function

Figure 2. Analysis condition

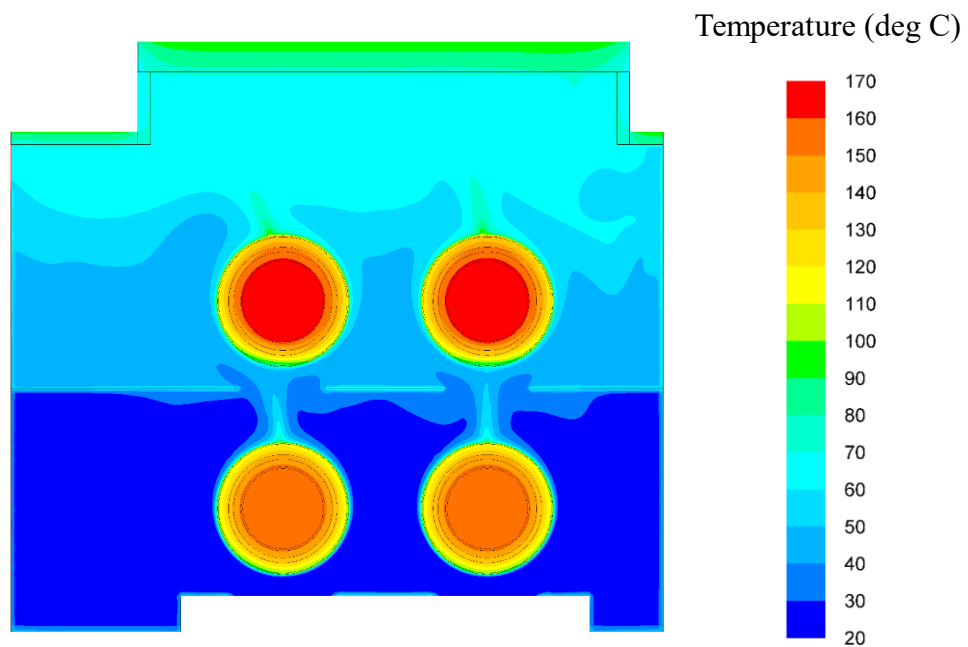

Figure 3. Temperature distribution under cooling device running

Under Loss of Cooling Function

Time history of temperature in the hold under loss of cooling function was calculated by FLUENT code considering the distribution temperature shown in figure 3 as an initial condition of this analysis. Analysis condition under loss of cooling function is the same as shown in figure 2, except the inlets and the outlet were changed into insulation conditions. Time history of temperature on the external surfaces of the packages after loss of cooling function is shown in figure 4.

Considering the time history of temperature on external surface of the package, which is the highest temperature of four packages, as the boundary condition in this analysis, period of time maintaining the seal integrity of the package was evaluated by thermal transfer analysis using ABAQUS code.

Analysis model of NFT-14P type package is shown in figure 5. The package has a water level in the cavity. If the package temperature rises, cavity pressure soars accompanying with water swelling. The seal integrity of elastomer gasket used in the package can't be ensured after the cavity pressure exceeds 6.9MPaG [1]. So we assumed that the seal integrity would be broken when cavity pressure reaches 6.9MPaG. Cavity water temperature corresponding to the pressure of 6.9MPaG can be calculated by Boyle-Sharle's law, which is 211 degrees Celsius in case of NFT-14P type package.

Time history of cavity water temperature after loss of cooling function is shown in figure 6. The cavity water temperature reached 211 degrees Celsius a little more than 8 hours after loss of cooling function, which indicates the seal of the package could be broken.

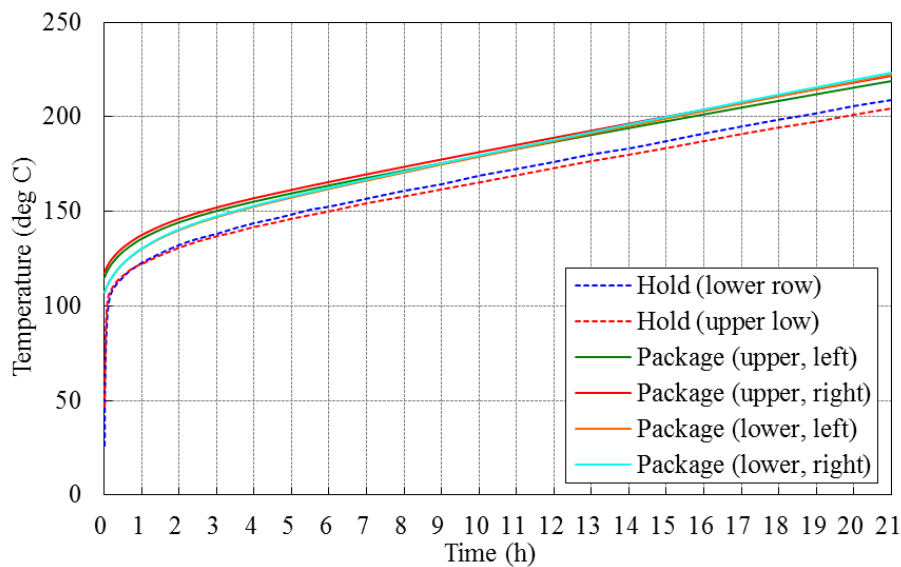

Figure 4. Time history of temperature on external surfaces of the packages after loss of cooling function

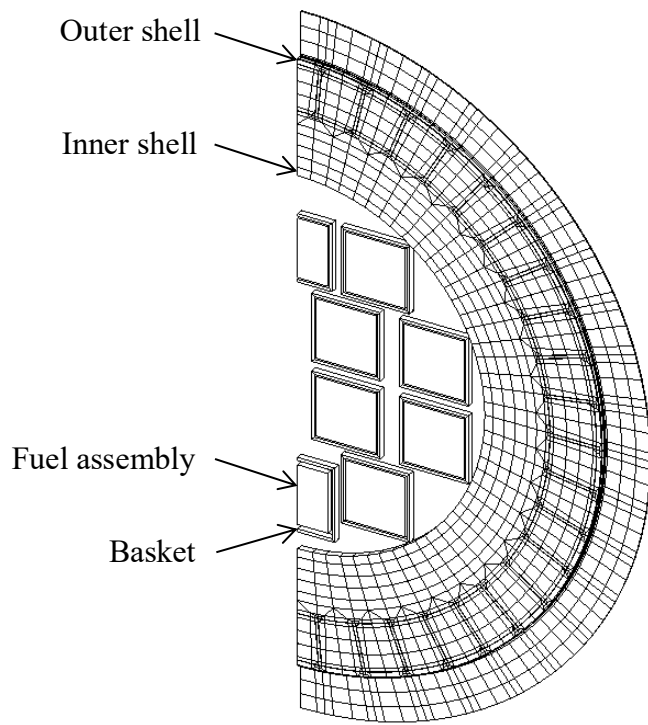

Figure 5. Analysis model of NFT-14P package

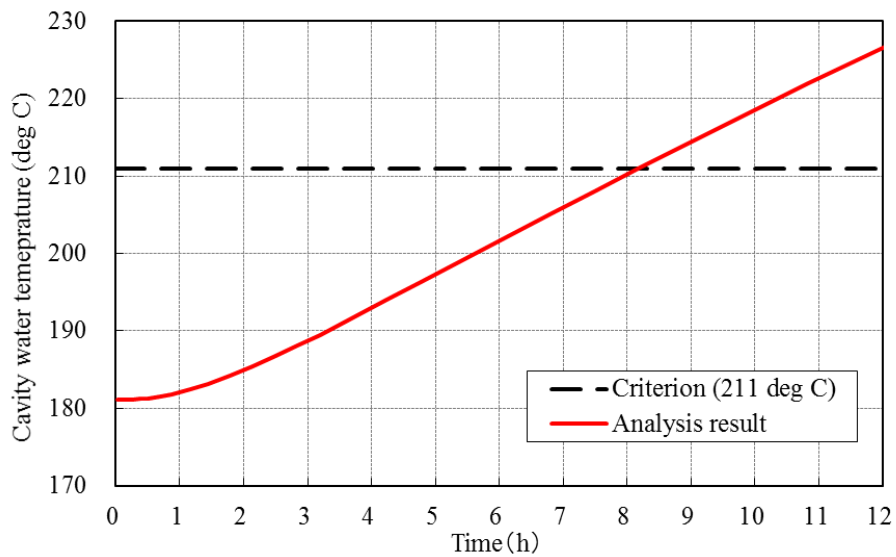

Figure 6. Time history of cavity water temperature after loss of cooling function

STUDY ON MITIGATION MEASURE

Opening all apertures, which enables air to ventilate between the inside of the hatch and outside of the ship, was considered as a realistic mitigation measure because they can be opened by hand without power supply. In order to grasp effect of the mitigation measure, thermal fluid dynamic analysis and following thermal transfer analysis were conducted. Analysis condition with all apertures open is shown in figure 7. Details of the analysis condition is mentioned below.

- (a) Analysis condition is the same as precedent analysis, except three apertures were modeled.
- (b) Although there is an air duct which connects upper deck and lower row hold in reality, we modeled an inlet through which ambient air at 38 degrees Celsius flowed into the lower row hold.
- (c) The size of each aperture in the analysis model is coordinated so that the cross section of each aperture in the analysis model corresponds to the real cross section.

Owing to opening all apertures, the period of time maintaining the seal integrity of the package extended to little more than 17 hours after loss of cooling function, which indicates the mitigation measure is effective.

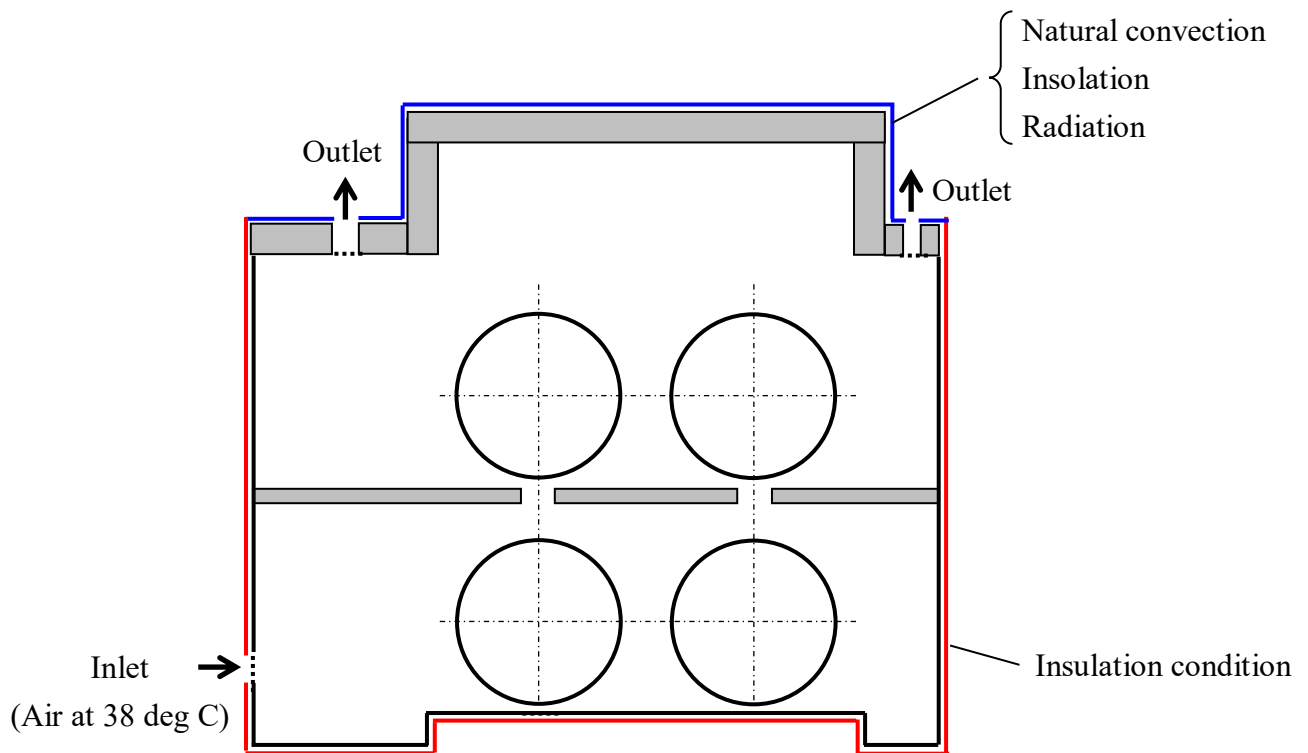

Figure 7. Analysis condition for study on mitigation measure

PARAMETER SURVEY ON HEAT GENERATION RATE

In order to evaluate the limit of the heat generation rate which ensure the seal integrity of the package at thermal equilibrium after loss of cooling function, we conducted thermal fluid dynamic analysis and the following thermal transfer analysis in consideration of opening all apertures. Analysis condition for this survey is shown in figure 8.

- (a) Analysis model was changed to be more realistic, modeling outside of the hold as well as inside of the hold in 2D.
- (b) The number of packages loaded in the hold is two, three or four in this survey. In each case, the heat generation rate of the package was varied so that the seal integrity of the package can be maintained.
- (c) The packages were modeled at right angles to the actual direction of the packages loaded in the hold, which barely have any effect on the results of this survey.
- (d) Although some tanks which contain fuel oil, ballast water and so on are located between inside walls and outside walls of the ship, the amount of them in the tanks can vary depending on shipping conditions. So we assumed conservatively that air is filled between inside walls and outside walls, and the air is only allowed to transfer thermal by conductivity.
- (e) The size of each aperture in the analysis model is coordinated so that the cross section of each aperture in the analysis model corresponds to the real cross section.
- (f) A widespread area filled with air is modeled above the ship, which is connected to the apertures.
- (g) The ambient air temperature around the ship was set to 38 degrees Celsius.

The temperature on the external surfaces of the packages at thermal equilibrium was calculated by FLUENT code. Then considering the highest temperature of them as a boundary condition, cavity water temperature was calculated by ABAQUS code using the analysis model shown in figure 5.

As shown in table 1, the seal integrity of the packages could be maintained without restricting the heat generation rate of the packages in case of up to two packages loaded in the hold. The seal integrity of packages could also be maintained by restricting the heat generation rate of the packages to 46kW and less in the case of three packages and to 42kW and less in the case of four packages.

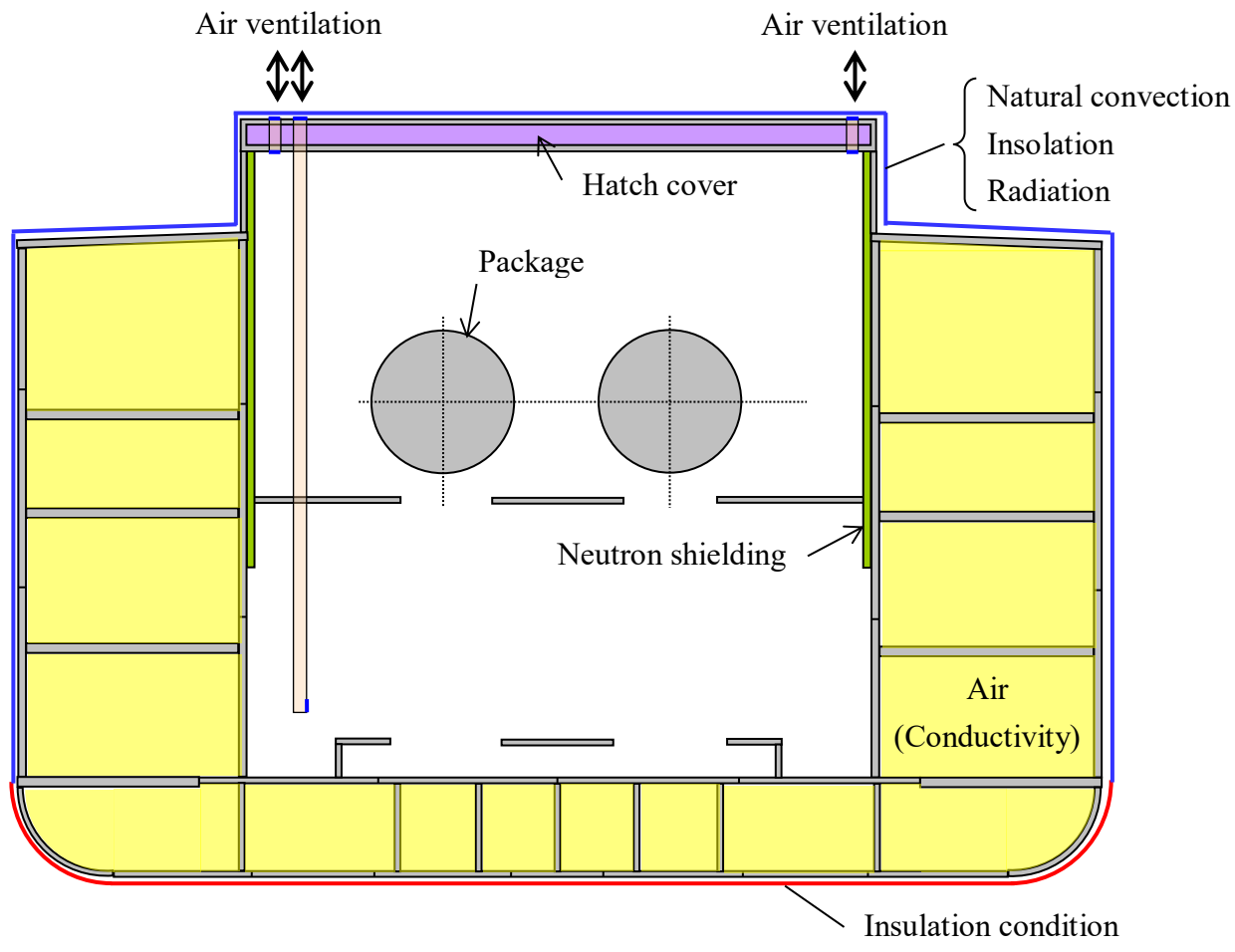

Figure 8. Analysis condition for parameter survey on heat generation rate

Table 1. Result of parameter survey on heat generation rate

| Number of packages | Heat generation rate | Outer shell temperature (FLUENT) | Cavity water temperature (ABAQUS) | Criterion for cavity water temperature |
|--------------------|----------------------|----------------------------------|-----------------------------------|--|
| 2 | 54 kW | 146 deg C | 209 deg C | 211 deg C |
| 3 | 46 kW | 154 deg C | 208 deg C | |
| 4 | 42 kW | 160 deg C | 210 deg C | |

Note: The high design heat generation rate of NFT-14P type package is 54kW

CONCLUSION

Hazard Assessment for loss of cooling function, which may occur as a result of tsunami, was conducted in this study.

In case of the maximum number (four) of packages loaded in the hold with high design heat generation rate of 54kW, the seal of package could be broken a little more than 8 hours after loss of cooling function.

As a realistic mitigation measure, opening all apertures was considered. The mitigation measure extends the period of time maintaining seal integrity of the package to little more than 17 hours after loss of cooling function, which indicates the mitigation measure is effective.

Finally, we obtained the restriction of heat generation rate, which ensures the seal integrity of the package at thermal equilibrium after loss of cooling function, according to the number of packages loaded in the hold under taking the mitigation measure.

We plans to take the restriction into the transport plan and take opening all apertures into operation procedure in the future, in case that loss of cooling function occurs. When the time comes that a new ship takes over from the ship for spent fuel shipments, we will try to design a new ship capable of cooling packages only by opening all apertures without restricting the heat generation rate during loss of cooling function.

REFERENCES

- [1] VALQUA HAND BOOK TECHNICAL DATA, VALQUA, Ltd.,
http://www.seal.valqua.co.jp./seal/gasket_detail_tech/076/