

Paper No. 1332

Study on Heat Flow Analysis Modeling for Transport Packages with Radial Fins

Tatsuya ITO¹, Hironori MIZOBUCHI¹, Shigeo HONDA¹, Haruaki KIKUCHI¹,
Tatsuya MINAMI²

1. OCL Corporation, 6-2-40, Nakanoshima, Kita-Ku, Osaka 530-0005, Japan
2. Nuclear Fuel Transport Co., Ltd., 1-1-3, Shiba Daimon, Minato-ku, Tokyo 105-0012, Japan

ABSTRACT

Some spent nuclear fuel transport packages have radial fins to enhance heat removal by natural convection during transport placed in horizontal orientation. During the handling, they are temporally located vertically. In this case, heat removal behavior from outer shell of the packages varies due to change of air flow around the fins from that of horizontal orientation. Therefore, the heat removal performance of the vertically located packages was studied using FLUENT code. The code was verified using the data obtained in the thermal test with a model package. As the test data, results of heat transfer test using test body that simulated a package were used. As results of this study, the heat flow analysis model that demonstrated enough precision was developed. In the future, comparison of the heat removal performance in vertical orientation to that in horizontal orientation will be performed using the developed model.

INTRODUCTION

Some spent nuclear fuel transport packages that are placed in horizontal position during transport have radial fins to enhance heat removal by natural convection. During the handling of the packages before and after transportation, they are temporally set vertically. In this case, heat removal behavior from outer shell of the packages varies due to change of air flow around the fins from that in horizontal position. The heat removal behavior from outer surface of packages by natural convection is often evaluated using empirical formula such as Jakob's equation [1]. Such empirical formula can be applied to the evaluation of the heat removal behavior of the packages with radial fins in horizontal position. However, there is no suitable empirical formula to apply to the evaluation of that in vertical position. Therefore, it is necessary to evaluate the behavior of such cases by a test or simulation by analysis code. And also, it is necessary that the method of the simulation by the analysis code is validated by comparing with the test data.

In the present study, the heat removal performance of the vertically located packages is studied using FLUENT code [2]. Appropriate modeling method is also studied by comparing with the test data obtained in heat transfer test using test body that simulated a package.

HEAT TRANSFER TEST

The heat transfer test body simulates a part of the NFT-22B type spent nuclear fuel transport package with radial fins shown in Fig.1. The outline of the test body is shown in Fig.2. The test body is composed of body shell, heat transfer fins, outer shell, and fins. A heater is attached to the inner surface of the body shell. Power of the heater is 700W and 175W. These values correspond to about 20 kW and 5 kW decay heat, respectively, for the NFT-22B type package. An insulator is placed on the outer surface of the test body excluding periphery of the outer shell and the fins. The insulator is, additionally, placed in the region between the body shell and the outer shell instead of neutron shielding materials.

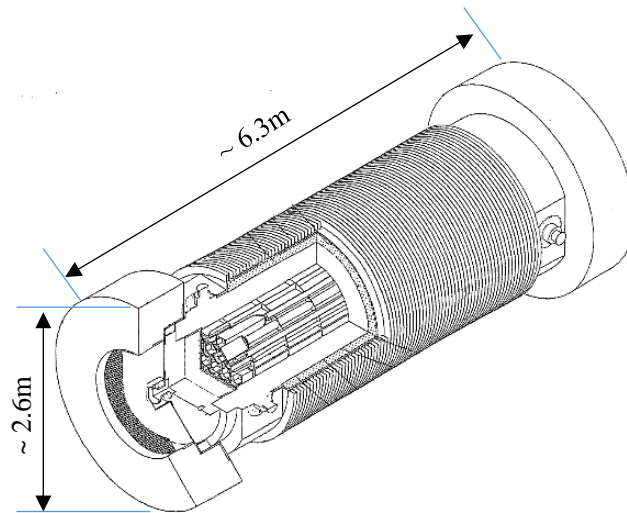

Fig.1 NFT-22B type transport package

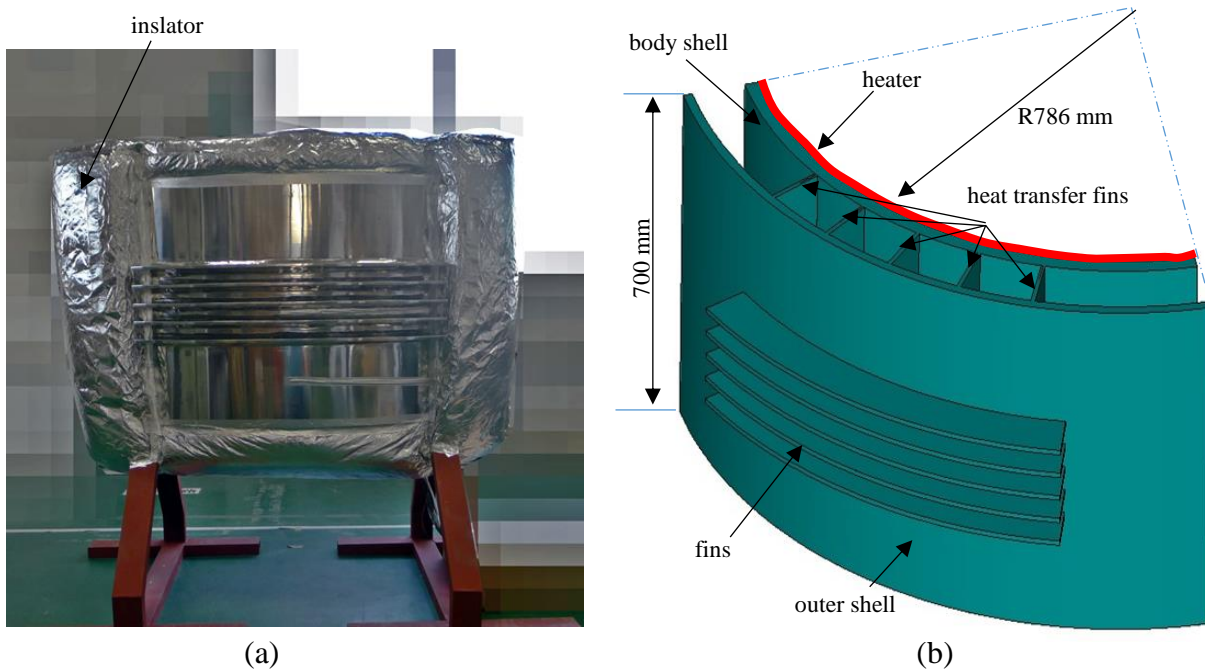
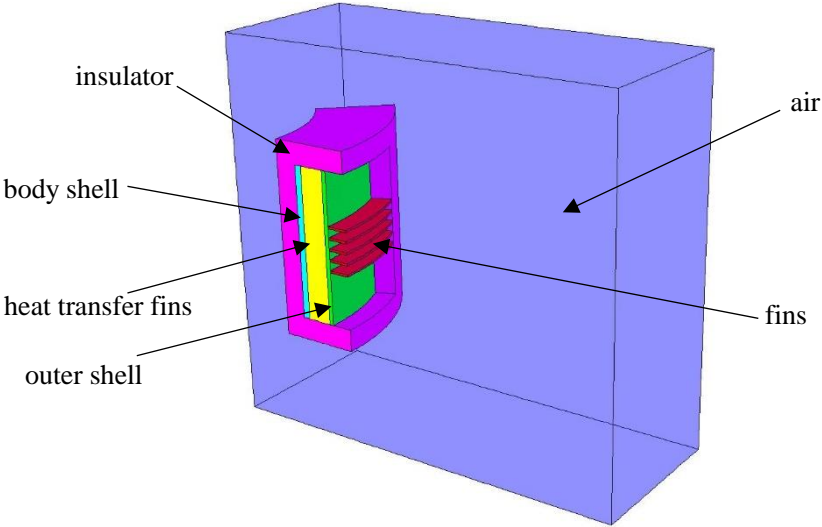

Fig.2 Outline of the test body (a) picture, (b) shape and dimension

DEVELOPMENT OF ANALYTICAL MODEL

ANALYSIS MODEL AND CONDITION

The analysis model is shown in Fig.3 and details of analysis condition are shown in Table 1. The analysis model is half size of the test body in consideration of symmetry of the shape of that. The analysis model is composed of body shell, heat transfer fins, outer shell, fins, insulator and air around the test body. The air is modeled as fluid and the other components are modeled as solid. The heat power of 350W or 87.5W (half of 700W or 175W) is directly loaded from the inside of the body shell instead of modeling actual heater.



(a)

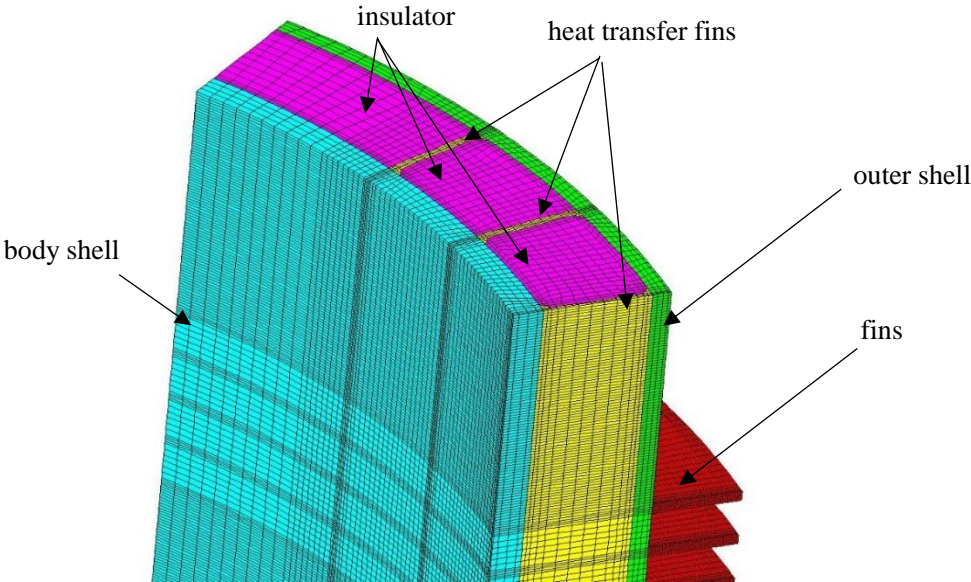

(b)

Fig.3 Analysis model (a) whole, (b) components modeled as solid

Table 1 Details of analysis condition

Type of calculation : Steady state analysis	
FLUENT version : 14.5	
Viscous model : Realizable k- ϵ turbulence model, Full Buoyancy Effects	
Mesh size of air near the test body : ~3mm	
Wall Treatment : Non-Equilibrium Wall Functions	
Radiation : Discrete Ordinate (DO) Model	
Density of air : incompressible-ideal-gas	
Operating Pressure : 101325 Pa	
Operating Density : Density of air at environmental temperature	
Discretization Scheme	Pressure : PRESTO! Pressure-Velocity Coupling : Coupled Momentum, k, ϵ , Energy, DO : First Order Upwind
Boundary Conditions	Top : inlet/outlet of air Side and Bottom : adiabatic

COMPARISON TO TEST DATA

Fig.4 and Fig.5 show temperature comparison between test data and analysis results at 700W and 175W, respectively. Temperature differences between the analysis results and the test data are about 10°C at the maximum. Both at 700W and 175W, the analysis results agree well with the test data. Therefore, the analysis model has enough precision.

RESULTS

Velocity vector of air around the test body at power of 700W is shown in Fig.6. The velocity of air is larger at the lower part of the outer shell, the tip of the fin and the upper part of the outer shell and smaller in the space between the fins. From this, it can be seen that the air around the test body flows upward through the tip of the fins from the lower part of the outer shell, on the other hand, little air flows into the space between the fins. Temperature distribution of the surface of the outer shell and the fins at 700W is shown in Fig.7. The temperature of the outer shell surface near the heat transfer fins is higher than the temperature of the other surfaces of the outer shell. The developed model can simulate temperature distribution on the outer surface of the outer shell. In addition, the temperature of the upper part of the outer shell is higher than that of the lower part of the outer shell. This is because little air flows into the space above top of the fins (see Fig.6).

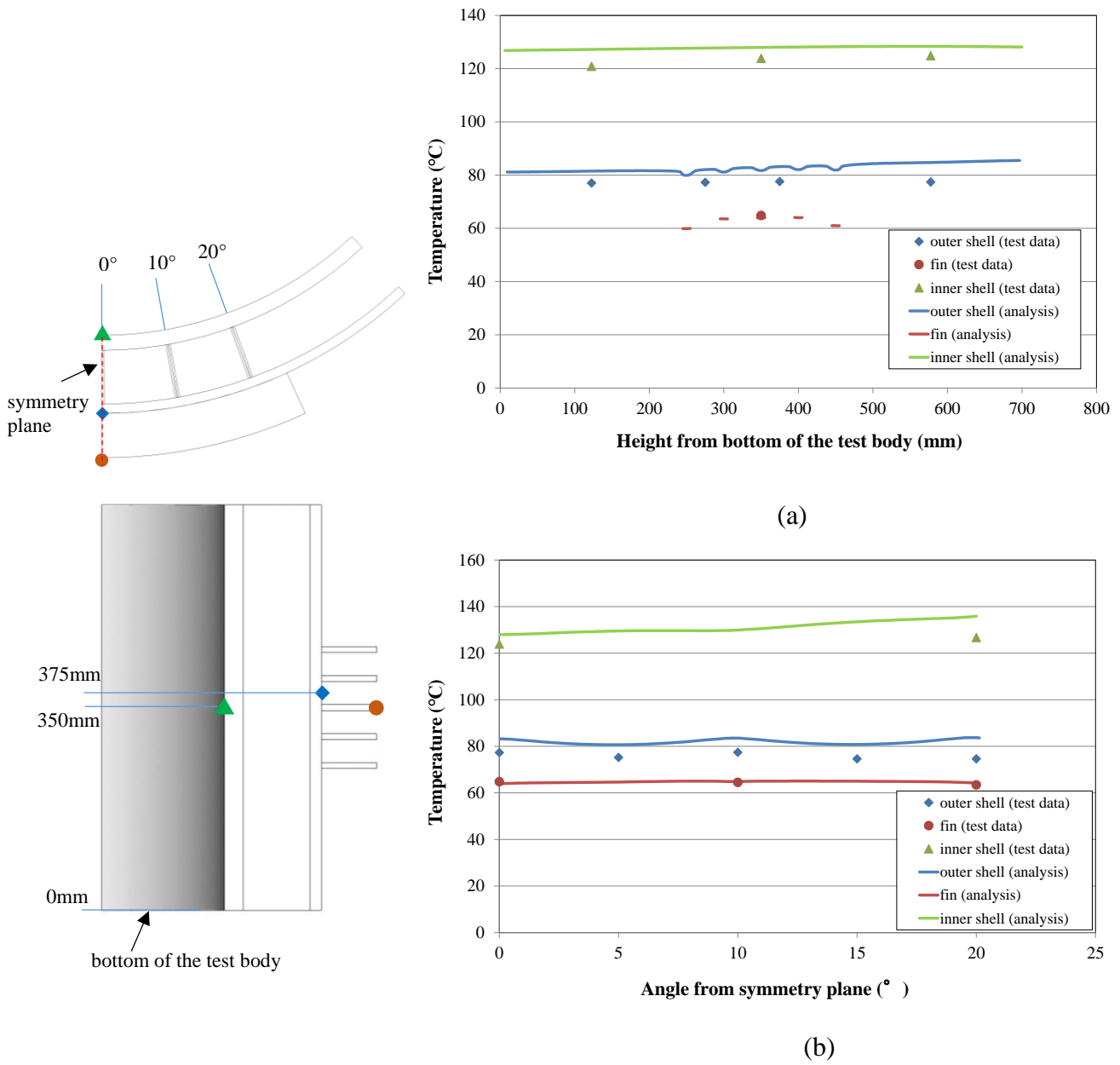

Fig. 4 Temperature comparison between test data and analysis results at 700 W (a) height distribution at the symmetry plane position (b) circumferential distribution at the center of the test body

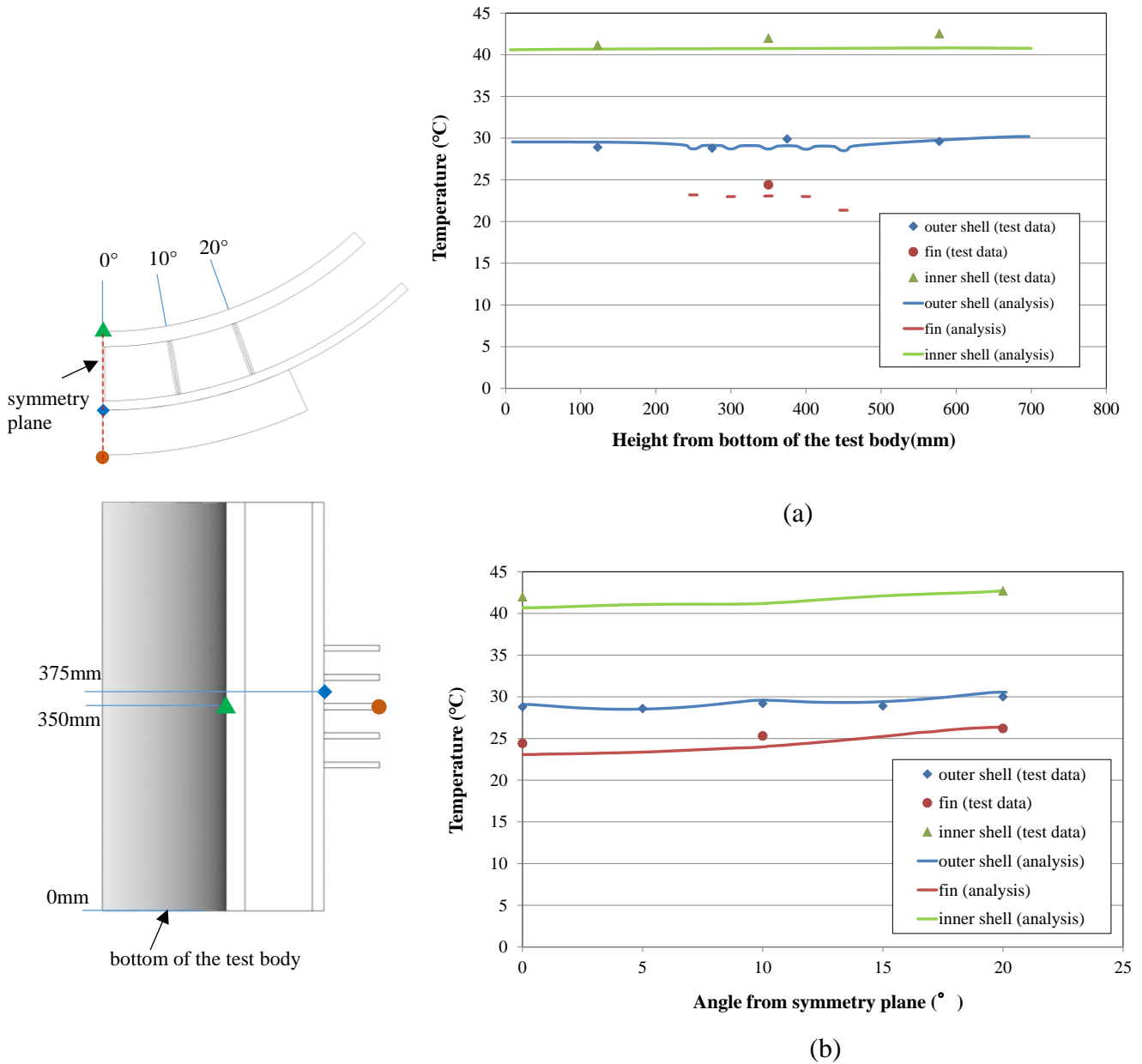

Fig. 5 Temperature comparison between test data and analysis results at 175 W (a) height distribution at the symmetry plane position (b) circumferential distribution at the center of the test body

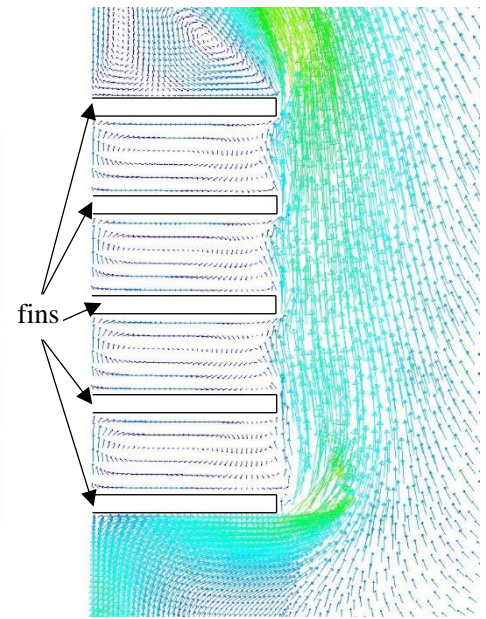
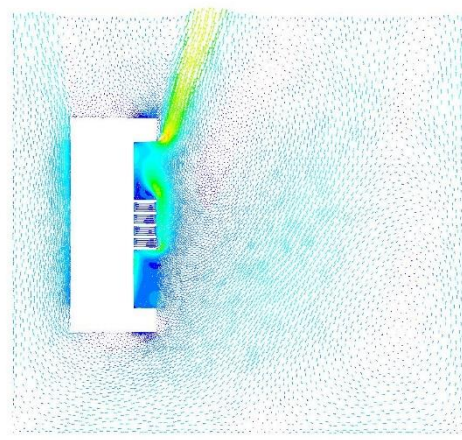
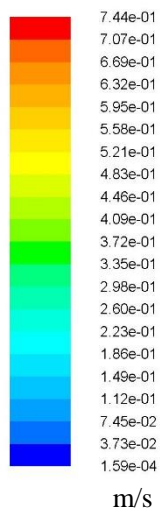

Fig.6 Velocity vector of air around the test body at 700W
(a) on the symmetry plane, (b) around the fins of (a)

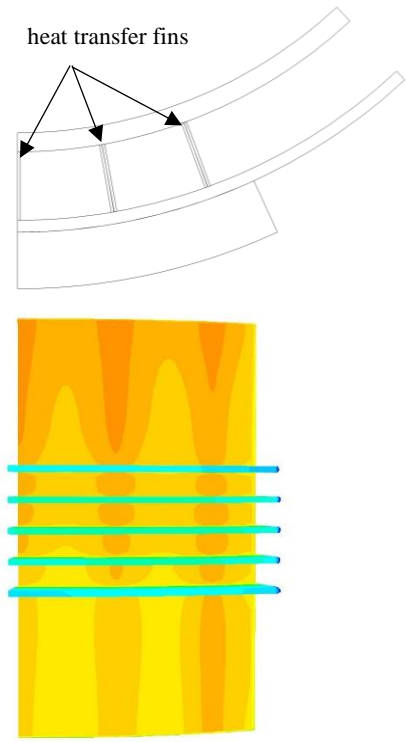
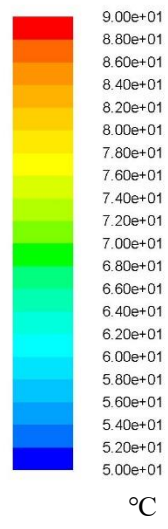

Fig.7 Temperature distribution on the surface of outer shell and fins at 700W

CONCLUSION

The applicability of the analysis model and heat removal performance of the vertically located packages by natural convection were studied using FLUENT code. The analysis results of the developed model agree well with the test data. As results of the analysis, the developed model can simulate temperature distribution on the outer surface of the outer shell. Moreover, the air around the test body flows upward through the tip of the fins from the lower part of the outer shell and little air flows into the space between the fins. In the future, comparison of the heat removal performance in vertical orientation to that in horizontal orientation will be performed using the developed model.

REFERENCES

- [1] M.Jakob, "Heat Transfer", Volume I. John Wiley & Sons, Inc. (1962)
- [2] ANSYS, Inc. Web page. <https://www.ansys.com/Products/>