

DESIGN OF THE DEFENSE PROGRAMS PACKAGE 3 (DPP-3)

Peter J. Sakalaukus Jr.

orcid.org/0000-0003-3691-4210

Pacific Northwest National
Laboratory, Richland, WA, USA

Nathan P. Barrett

orcid.org/0000-0001-5301-7066

Pacific Northwest National
Laboratory, Richland, WA, USA

Brian J. Koeppel

orcid.org/0000-0002-9529-5088

Pacific Northwest National
Laboratory, Richland, WA, USA

ABSTRACT

The Pacific Northwest National Laboratory (PNNL) is the design authority for a new Type B hazardous materials transportation package designated as the Defense Programs Package 3 (DPP-3) for the U.S. Department of Energy (DOE) National Nuclear Security Administration (NNSA). The DPP-3 is intended to be a replacement for older DT-series packages that will be phased out of service. The DPP-3 has been developed using similar materials and fabrication methods employed in previous U.S. Nuclear Regulatory Commission (NRC), DOE, and NNSA certified packages. The DPP-3 design criteria are derived from the American Society of Mechanical Engineers (ASME) Boiler and Pressure Vessel Code (BPVC), NNSA guidance and NRC guides in order to safely and securely transport a variety of payloads.

The DPP-3 has been structurally analyzed using the Finite Element Analysis (FEA) software platform LS-DYNA from Livermore Software Technology Corporation (LSTC). The structural analyses performed for the DPP-3 serve two purposes: first, they aid in the design of the DPP-3 package during development, and second, they pinpoint which drop orientations will cause the most damage to the package during regulatory testing, since this package will be certified by the NNSA based on testing. Final acceptance by the NNSA will require experimental demonstration that the containment vessel (CV) housed within the drum overpack remains leaktight after enduring the entire regulatory testing sequence prescribed in Title 10 of the Code of Federal Regulations Part 71 (10 CFR 71). This paper will discuss the design approach, FEA structural evaluations for normal conditions of transport (NCT) and hypothetical accident conditions (HAC), evolution of the DPP-3 package design, and the lessons learned in development of the prototype design.

INTRODUCTION

The Pacific Northwest National Laboratory (PNNL) is the design authority for a new U.S. Department of Energy (DOE) National Nuclear Security Administration (NNSA) Category I, Type B hazardous materials transportation package designated as the Defense Programs Package 3 (DPP-3) that must comply with all applicable regulatory and guidance documents. The DPP-3 packaging design must meet the regulatory requirements for containment, shielding, subcriticality, and other safety features as outlined in Title 10 of

the Code of Federal Regulations Part 71 (10 CFR 71) [1]. The primary functions of the DPP-3 overpack is to provide confinement of the containment vessel (CV), thereby providing protection from postulated drop, vibration, and thermal events as defined in 10 CFR 71 and commonly known as the normal conditions of transport (NCT) and hypothetical accident conditions (HAC), sequential testing. By protecting the CV from damage, containment can be assured, thus protecting the public from potential release of hazardous materials.

The DPP-3 is intended to be a replacement for older DT-series packages which have been grandfathered into the program due to being no longer compliant with the current regulations. Therefore, the DT-series packages will be phased out of service once the DPP-3 has been approved by the regulatory body. The DPP-3 has been developed using similar materials and fabrication methods employed in previous U.S. Nuclear Regulatory Commission (NRC), DOE, and NNSA certified packages. This approach was chosen to leverage the immense amount of prior knowledge within the packaging community on the materials and processes used successfully in the past to ensure public safety—the number one goal of transport packages for radioactive material.

While the regulations predominately contain performance standards, the construction requirements for the DPP-3 were developed following the guidance of NUREG/CR-3019 *Recommended Welding Criteria for Use in the Fabrication of Shipping Containers for Radioactive Materials* [2] and NUREG/CR-3854 *Fabrication Criteria for Shipping Containers* [3]. These guidance documents stipulate the use of ASME BPVC Section III, Division 1 Subsection NB (III-NB) [4] as the construction code of choice for Class 1 nuclear components, which is what a containment vessel (CV) is typically treated as in the transportation community. Additionally, the use of III-NB is in line with NRC's Regulatory Guide 7.6 [5] and NNSA 2012 Interim Guidance which based off the WRC Bulletin 429 [6]. Therefore, the DPP-3 design criteria have been derived following III-NB Subparagraph NB-3200 *Design by Analysis*, as well as other applicable DOE, NRC, and NNSA guidance in order to safely and securely transport a variety of payloads.

The final DPP-3 design has been structurally analyzed using the explicit Finite Element Analysis (FEA) software platform LS-DYNA [7]. The structural analyses performed for the DPP-3 served multiple purposes. First, FEA aided in the design process of the DPP-3 package to determine the final prototype design choice that was most viable based off the package response to the simulated NCT and HAC structural performance tests. This approach gave confidence that the prototypic DPP-3 packages based off the proposed final DPP-3 production drawings will successfully pass the 10 CFR 71 testing criteria. Second, FEA gives insight and assurance as to which drop orientations will cause the most damage to the package during regulatory testing, since this package will be certified by the NNSA through testing of a limited number of test configurations. Regardless of what the DPP-3 packaging looks like after it has gone through the required 10 CFR 71 NCT and HAC sequence of tests, the final acceptance criteria by the NNSA is a demonstration that the CV housed within the DPP-3 packaging remains leaktight as defined by ANSI N14.5 [8]. Upon successful completion of the 10 CFR 71 regulatory test, the testing results will be used to validate the FEA models in order to allow for potential new contents in the future without the need to perform additional regulatory testing. This paper will discuss the prototypic design approach, FEA structural evaluations for NCT and HAC, evolution of the DPP-3 package design, and the lessons learned in development of the prototypic design.

DPP-3 PACKAGE

Figure 1 depicts a cutaway image of the prototypic DPP-3 package design for testing which illustrates the use of impact limiters (GP Foam, TR-19HS), thermal insulating materials (GP Foam, TR-19HS, Fiberfrax LTC HSA thermal blanket) and the CV, which is constructed from 304L stainless steel. The maximum

allowable gross shipping weight of the DPP-3 package is 1700 lbs. (~771 kg). The overall dimensions of the DPP-3 package are 36.5 in. overall diameter, 52 in. overall height. The approximate volume of the package is approximately 212 gal., Table 1 shows the main package component weights, as well as the maximum allowable gross shipping weight.

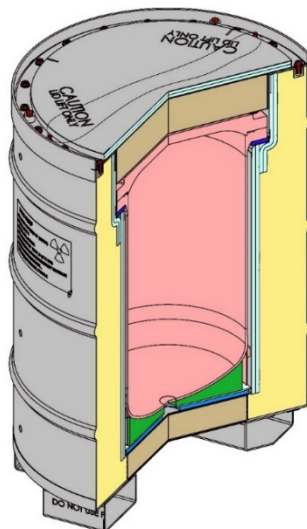

Figure 1. DPP-3 package cutaway

Table 1. DPP-3 package weights

Part	Weight (lb.)
Drum assembly (including Fiberfrax LTC HSA thermal blanket, GP FR-3710 foam, and perforated metal with encapsulated TR-19HS)	592
Drum lid (including fasteners)	134
Drum/CV vibration pads and CV support saddle	11
CV (flange, body, and skirt)	261
CV lid (including fasteners)	247
TOTAL EMPTY WEIGHT	1245
ESTIMATED MAXIMUM GROSS WEIGHT	1700

DPP-3 OVERPACK ASSEMBLY

The primary function of the DPP-3 overpack is to provide confinement of the CV, as well as protection from postulated impact, vibration, and thermal events. The DPP-3 overpack consists of an outer drum shell weldment, an inner liner weldment and a flanged, bolted lid with 20 ASTM A320 Grade L7 bolts. Within the drum are thermally insulating and impact limiting materials, vibration isolating materials, and CV support features.

The overpack is designed in such a way as to absorb as much damage from the required regulatory drops and fire event as possible with minimal transmission of forces or elevated temperatures to the CV. Minimizing the transmission of forces and temperatures to the CV provides confidence that a containment breach will not occur, i.e., the closure around the self-energizing O-rings will not be damaged by the sequential drops and the O-rings will stay below their operational temperature limit throughout the postulated thermal event. To aid in this, the large cavity between the drum walls and drum liner is filled with LAST-A-FOAM FR-3710, a rigid, closed cell polyurethane flame retardant foam manufactured by General Plastics (GP) [9]. The 10 pcf. GP Foam acts as an impact limiter and a thermal barrier. This

density was established through scoping LS-DYNA analyses of the DPP-3 to ensure the foam is not too stiff, which would transmit high impact loads to the CV. This foam is poured into the cavity between the drum exterior wall and the drum liner weldments through pour holes on the bottom of the drum base. Once completed, these pour holes are capped and welded. Vent holes are required on the exterior of the drum to allow jetting to occur during the required HAC thermal test. The number and size of these vent holes was chosen using the GP design guide [9]. In addition to providing the DPP-3 package with a layer of impact limiting protection, the GP foam also provides a thermally insulating barrier between the CV and the environment. In the event of exposure to fire, this foam can potentially burn. However, it does so while it intumesces, expanding rapidly to starve local hot regions of oxygen, thus discouraging the fire from spreading within the drum body. Some examples of packages that use the FR 3700 series polyurethane foams include the 380-B and 435-B (NRC certified packages); the RTG (DOE certified package); and the 9977, the H1700, and the BTSP-1 packages (NNSA certified packages). One lesson learned during drum overpack design was how to properly balance the need for a relatively soft impact limiter during the 4 ft. NCT drop event with a relatively stiff impact limiter during the 30 ft. HAC drop event. The outcomes from this lesson learned are seen in the foam density selection for the drum overpack and in the design features on the CV skirt, discussed below.

The drum weldment is primarily constructed from 0.0625 in. thick (16 gauge) ASTM A240, Type 304L stainless steel. Various other thicknesses of 304L stainless steel are used throughout the drum where stiffer sections are required to maintain structural rigidity, such as in the drum bolt guard (1/4 in. thick), the drum base guard (1/8 in. thick), and the drum liner support (3/16 in. thick). Multiple welding operations are performed to create the drum weldment which is shown in Figure 2.

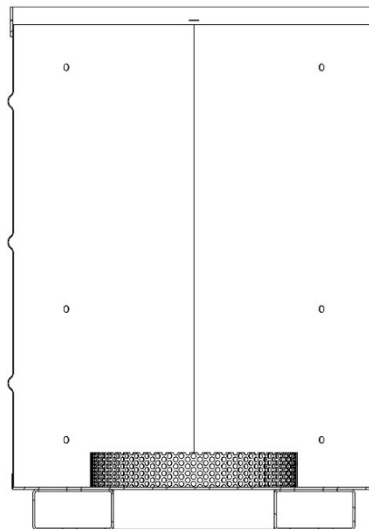

Figure 2. DPP-3 Drum exterior drum weldment and perforated liner support

Welded to the inside bottom of the drum exterior weldment is a perforated liner support ring, also shown in Figure 2. This ring is composed of 1/8 in. thick sheet metal constructed of ASTM A-240, Type 304L stainless steel with 1/2 in. diameter perforations on a flat plate that is rolled into a cylinder and welded together. The perforated liner support ring provides mechanical support for the liner during normal loading, handling, and transport conditions to mitigate liner displacement over the lifetime of the package. The design allows for buckling deformation to occur during the HAC regulatory testing which was confirmed via scoping FEA. This reduces the amount of excess mechanical energy imparted onto the CV during the drop event, thereby reducing the stresses on the CV. The perforated ring also attenuates the

thermal path from the extreme heat of the package exterior to the CV during regulatory thermal testing. Additionally, a block of TR-19HS is located within the perforated ring. TR-19HS is a thermal insulating block made from vermiculite granules and high temperature bonding materials by Morgan Thermal Ceramics [10] and is rated for continuous use at temperatures up to 1900°F, even when exposed to direct flame. A similar product, TR-19, which has identical constituents formed at a lower crush strength, is used in other shipping packages, such as the 9977 and H1700.

The drum liner weldment is composed of various thicknesses of ASTM A-240, Type 304L stainless steel. The drum liner design was developed, analyzed, and iterated after using multiple FEA models to determine the suitable thickness and shape of the drum liner shelf in order to reduce total construction cost, prevent fatigue, and to maintain public safety. A lesson learned during this development task was to work closely with the fabricator during the design process. The original design proved to be too difficult to fabricate. This required the design team to develop and test different designs in LS-DYNA, while coordinating with the fabricator to ensure the design could be manufactured easily.

Once the drum liner weldment has been created, two layers of ½ in. thick Fiberfrax LTC HSA thermal blanket is wrapped and secured to the liner, as shown in Figure 3. LTC HSA is a quilted blanket formed from layers of ceramic fiber paper covered in woven textile cloth [11] and is an excellent thermal insulator. Then, with the TR-19HS glued into the space inside the perforated liner support ring, the drum exterior weldment and the liner weldment are joined together by welding the drum liner lip to the drum bolt guard.

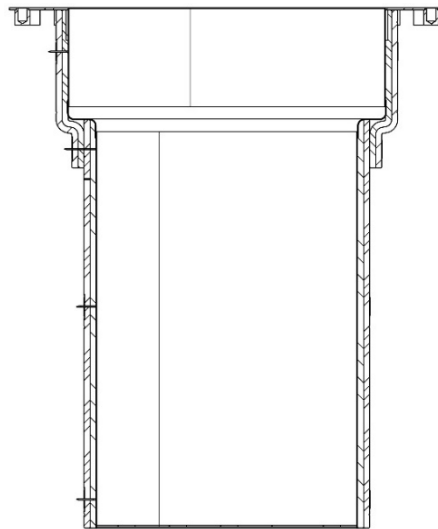

Figure 3. DPP-3 drum liner weldment

The drum lid is fabricated from a 1/8 in. thick bolt plate with 0.0625 in. thick (16 gauge) chambers above and below. The bolt plate, top, and bottom chambers are constructed of ASTM A-240, Type 304L stainless steel. Before welding, the space between the drum top and bottom chambers is filled with two 1/2 in. layers of Fiberfrax thermal blanket and with TR-19HS, respectively. Additionally, the TR-19HS acts as an impact limiter during the top end and top corner drop scenarios while creating an additional thermal barrier.

DPP-3 Packaging CV Support

The DPP-3 packaging supports the CV inside the drum liner cavity by three components: the CV saddle

plus upper and lower vibration pads. The purpose of the CV saddle is to have a reusable, durable support structure that will distribute handling and free drop loads across the entire surface of the CV torispherical head. The benefit of this design is that it creates a durable, low cost, lightweight support for the CV inside the drum liner cavity.

The CV saddle is constructed of Delrin acetyl resin and BJB Enterprises TC-284 flexible polyurethane foam and is shown in Figure 4. The flexible polyurethane foam will help absorb impact energy during NCT and HAC drop events. The CV saddle base provides a large surface area for the bottom vibration pad while locating and centering the saddle within the drum liner. Scoping FEA analyses were performed to determine the best CV saddle design. A lesson learned during the development of the CV saddle was how the various soft and stiff components surrounding the CV will impart mechanical energy to the CV during impact (NCT and HAC) and vibration events. The design of the CV saddle is the result of compromises to satisfy the different loading scenarios.

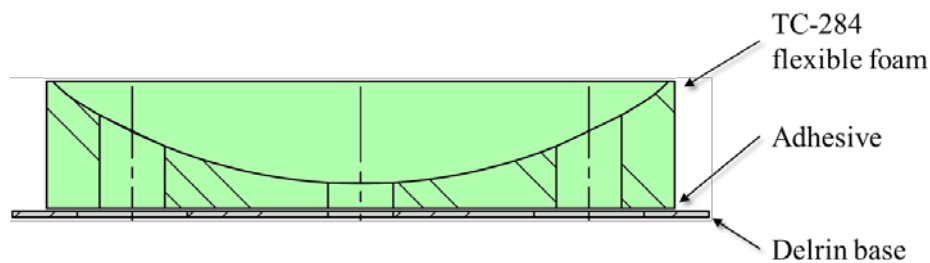

Figure 4. DPP-3 CV saddle support system

The upper and lower vibration pads between the CV and the drum liner protect both the CV and drum liner from vibration and metal-on-metal contact during shipping. They are also meant to protect the liner from damage due to loading and unloading of the CV. The CV upper and lower vibration pads are being fabricated from BISCO BF-1000 silicone foam. However, the vibration pad design will be finalized with optimal vibration attenuation being the driving goal.

CONTAINMENT SYSTEM

The general design of the stainless-steel CV, shown in Figure 5, consists of a 1/4 in. cylindrical shell with a torispherical head and a closure lid constructed of ASME SA-240, Type 304L. Additionally, a flat-face flange is used and is constructed of ASME SA-182, Type F304L. A quantity of 20 bolts is used to secure the CV lid to the CV body and is to be constructed of ASME SA-320, Grade L43. The preliminary design calculations for the DPP-3 used the available consensus standards ASME BPVC and NUREG/CR-6007 [12] as a basis to develop an initial design of the CV and the required number of bolts. This was followed by scoping analyses performed with LS-DYNA to validate the prototypic DPP-3 design under impact events. The preliminary design calculations used physical, mechanical, and thermal properties for the CV and closure bolt materials from ASME BPVC Section II, Part D [13] for all calculations.

The CV bolts are designed to the ASME BPVC guidelines of Mandatory Appendix IX and Nonmandatory Appendix E [14]. Using a design pressure of 300 psig, which was proposed to adequately size the bolts and torques to ensure a large margin of safety on the containment boundary. A quantity of 20 CV bolts with a minimum root diameter of ~0.38 in. was determined using the calculation approach of NUREG/CR-6007. Initially, 1/2 in. bolts were used; however, upon completion of the scoping LS-DYNA analyses, it was shown that 5/8 in. diameter bolts were more appropriate for the type of impact loading the package is

expected to undergo during regulatory testing. Therefore, a bolt diameter of 5/8 in. with a root diameter of ~0.51 in. was chosen. The initial choice of 20 CV bolts is based on the conservative assumptions used with NUREG/CR-6007. The conservative equations in NUREG/CR-6007 were initially used to determine the number of bolts required to pass the NCT stress limits in Table 6.1 of NUREG/CR-6007. Scoping FEA validated the use of 20 CV bolts.

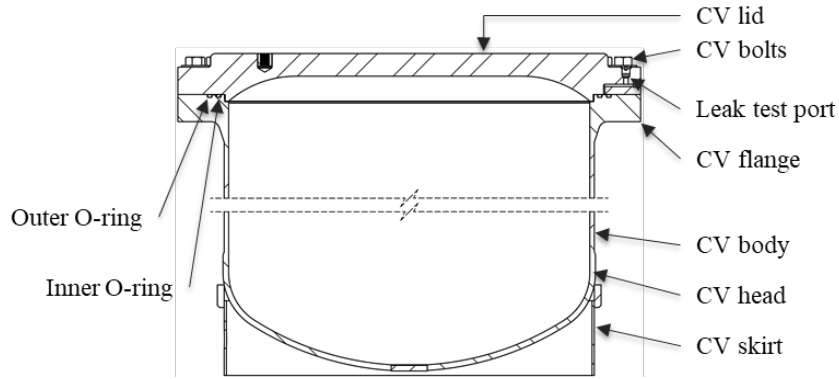

Figure 5. DPP-3 CV assembly

The DPP-3 CV uses a torispherical head at the bottom. The torispherical head will provide adequate structural strength and rigidity at a lower weight than a flat bottom head design, and at a shorter height than a stronger fully ellipsoidal head design. At 0.313 in. thick, the dished head is thicker than the main body of the CV by 1/16 in. This is to allow for the thinning of the dished head during manufacturing. By starting with a thicker material, the head thickness will remain at or above 1/4 in. once complete.

The design for the CV lid includes a mostly flat plate with a recessed bolt region and a curved underside. The curved underside of the lid improves the lid’s response to structural and vibrational loading while reducing the total lid mass. The raised lid (bolt guard) with an integrated shear ring design aids in protecting the bolts from shearing during HAC. The purpose of the shear ring on the CV closure lid is to protect the CV bolts from side impact loads. The CV lid bolt holes, shear ring, flange, and flange threaded bolt holes have all been held to appropriate tolerances to ensure the shear ring will always contact the flange before the lid contacts any of the bolts. Figure 6 shows this shear ring interface. Without the bolt guard and shear ring features, the bolts could be exposed to potential damage from side drops through excessive shearing stresses.

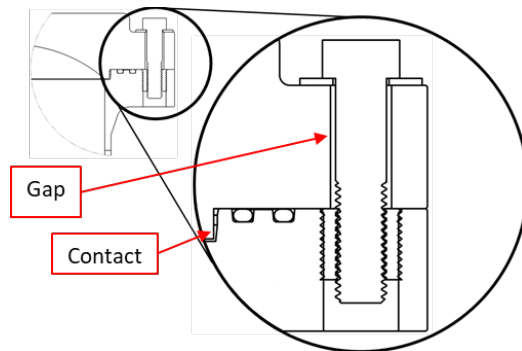

Figure 6. DPP-3 CV shear ring bolt protection design

The flange of the DPP-3 CV is machined to accept two concentric O-rings. The inner O-ring is credited

for containment for the DPP-3 CV and is designated to be leaktight (1×10^{-7} std. cm^3/sec , air) per the definition in ANSI N14.5, while the outer O-ring is used for the mandatory pre-shipment leakage-rate testing of to a sensitivity of at least 1×10^{-3} std. cm^3/sec , air. The DPP-3 package uses a single test port in the CV lid, as shown in Figure 7, which accesses the area between the two CV closure O-rings. This single port allows for the pre-shipment leakage-rate testing. The initial fabrication leakage-rate test, as well as the maintenance and periodic leakage-rate tests for leaktightness requires the use of a leak test flange placed between the CV lid and CV flange. The leak test flange has identical mating surfaces to the CV lid and CV flange.

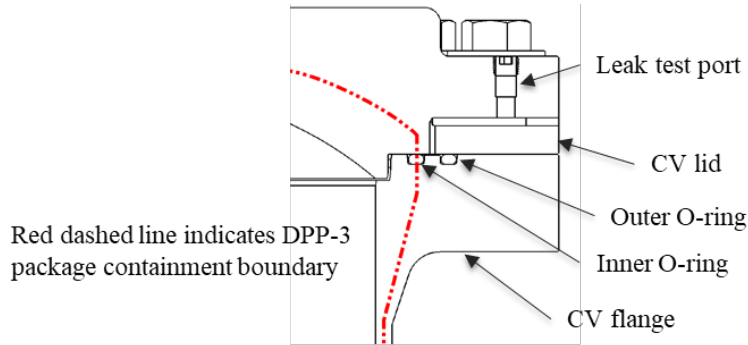

Figure 7. DPP-3 CV containment boundary with leak test port

The CV skirt, which is constructed of ASME SA-240, Type 304L, as shown in Figure 8, performs two functions. First, it provides a stable, flat surface for the CV to be placed on flat ground, as compared to current NNSA packages that require a specialized holder to place the CV upright. Second, the added material at the top of the CV skirt directs the load path during impact events into the knuckle region of the torispherical head. This keeps direct damage away from the CV walls, forcing impact locations at the CV flange/lid region and the CV knuckle regions, which have been designed with the ability to sustain higher loads. The initial CV skirt design did not have this additional material. Upon performing scoping analyses, it was shown that the stress intensities were too large in the CV body, i.e., cylinder portion, after completion of the NCT regulatory testing. It was determined that the GP foam was too stiff, which led to less energy being absorbed by this impact limiter. The lesson learned was that including the thicker material on the top of the CV skirt allows the NCT energy absorption to predominately be located locally in the torispherical head, which is stiffer and has a larger ASME BPVC allowable stress limit. Finally, a 1-in. vent hole is drilled into the wall of the skirt. This will allow air to pass through and will prevent the unintended vacuum seal of the CV bottom to the CV saddle or bell jar floor during leak testing.

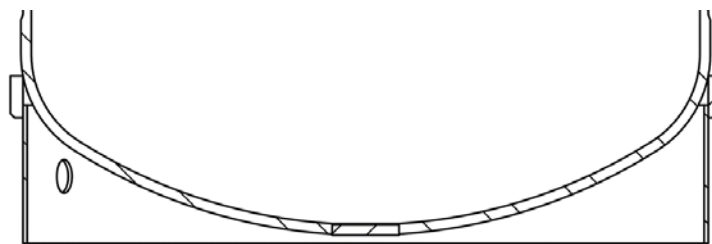

Figure 8. DPP-3 CV skirt

SCOPING FEA

Scoping FEA analyses were completed for a variety of drop scenarios and temperature conditions. The

results from these analyses aided in the decision to perform physical testing on six prototypic test units. The scoping analyses of the prototypic design showed the worst predicted cases to be: side drops at -20°F and 100°F (the coldest and hottest regulatory initial conditions), and top end, bottom end, top corner, and bottom corner drops at room temperature. A shallow angle or slapdown orientation will not be tested since this package has a low length/diameter ratio, and modeling results showed CV stresses were bounded by the other cases. The corner drops were oriented such that the center of gravity of the package was directly over the corner. The side drop analyses are predicted to be the worst case for the DPP-3, so the extreme temperature requirements of 10 CFR 71.71 are being used in those NCT and HAC tests. The top end, bottom end, top corner, and bottom corner drop analyses showed similar results at the cold, hot, and room temperature conditions. Therefore, room temperature was chosen as the appropriate condition for the remaining test units to test different orientations. Finally, the room temperature drops will validate some of the features included in the DPP-3, such as the TR-19HS blocks, perforated liner support ring, CV saddle, and the liner weldment design. Ultimately, the NNSA will certify this package when it is shown that the CV is leaktight as defined by ANSI N14.5 after the completion of all 10 CFR 71 regulatory requirements. The final, empty, prototypic DPP-3 package cross section is shown in Figure 9.

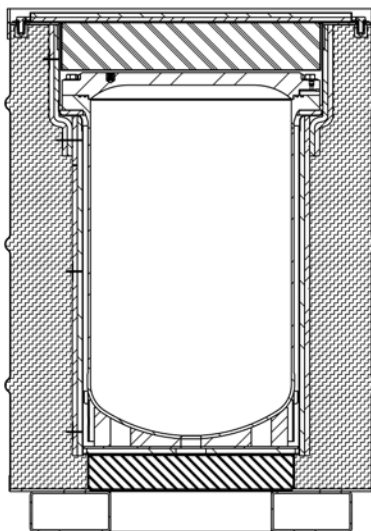

Figure 9. DPP-3 package cross section

CONCLUSIONS

PNNL is the design authority for a new Category I, Type B hazardous materials transportation package designated as the DPP-3 for DOE NNSA. The DPP-3 is intended to be a replacement for older DT-series packages that are being phased out of service. The DPP-3 has been developed using similar materials and fabrication methods employed in previous NRC, DOE, and NNSA certified packages. The DPP-3 design criteria were derived from the ASME BPVC, NNSA guidance, and NRC guides in order to safely and securely transport a variety of payloads.

The DPP-3 has been structurally analyzed using the FEA software platform LS-DYNA. The structural analyses performed for the DPP-3 helped finalize the design for prototype testing and determine the worst-case regulatory drop scenarios. Final acceptance by the NNSA will require demonstration that the CV remains leaktight after enduring the entire regulatory testing sequence as stated in 10 CFR 71. Future work will be to use the results from the 10 CFR 71 regulatory tests to validate the current FEA models in order to allow the possibility of new unforeseen contents without the need to perform additional regulatory

testing.

ACKNOWLEDGMENTS

The authors gratefully acknowledge the technical collaborations and contributions of fellow PNNL DPP-3 design, analysis, fabrication, and management team members. This work was funded by the NNSA Office of Infrastructure Operations and Modernization (NA-522) under U.S. DOE Contract DE-AC05-76RL01830.

REFERENCES

- [1] 10 CFR 71. 2019. "Packaging and Transportation of Radioactive Material," *Code of Federal Regulations*, year in effect at initiation of design.
- [2] NUREG/CR-3019. 1984. *Recommended Welding Criteria for Use in the Fabrication of Shipping Containers for Radioactive Materials*, U.S. Nuclear Regulatory Commission, Washington, D.C.
- [3] NUREG/CR-3854. 1985. *Fabrication Criteria for Shipping Containers*, U.S. Nuclear Regulatory Commission, Washington, D.C.
- [4] ASME. 2015. American Society of Mechanical Engineers, *Boiler and Pressure Vessel Code*, Section III, Division 1, Subsection NB.
- [5] RG 7.6. 1978. Rev. 1, *Design Criteria for the Structural Analysis of Shipping Cask Containment Vessels*, U.S. Nuclear Regulatory Commission, Washington, D.C., March 1978.
- [6] WRC Bulletin 429. 1998. *3D Stress Criteria Guidelines for Application*. J. L. Hechmer and G. L. Hollinger, New York, New York.
- [7] LS-DYNA. 2018. Livermore Software Technology Corporation (LSTC).
- [8] ANSI N14.5. 2014. *American National Standard for Radioactive Materials – Leakage Tests on Packages for Shipment*, American National Standards Institute, New York, New York.
- [9] General Plastics. 2012. *LAST-A-FOAM FR-3700 Crash & Fire Protection of Radioactive Material Shipping Containers, Design Guide*, Rev. 02.20.12. General Plastic Manufacturing Company, Tacoma, Washington.
- [10] Morgan Advanced Materials. 2016. *2016 TR Structural Block Insulation*. Datasheet Code Us: 10-14-100. Dated 02/2016, Morgan A.
- [11] Unifrax. 2006. *Fiberfrax HSA Paper Composite Systems, Product Information Sheet*. Form C-737-I. Effective 11/06, Unifrax I LLC, Tonawanda, New York.
- [12] NUREG/CR-6007. 1992. *Stress Analysis of Closure Bolts for Shipping Casks*, U.S. Nuclear Regulatory Commission, Washington, D.C.
- [13] ASME. 2015. American Society of Mechanical Engineers, *Boiler and Pressure Vessel Code*, Section II, Part D.
- [14] ASME. 2015. American Society of Mechanical Engineers, *Boiler and Pressure Vessel Code*, Section III, Appendices.