

Dual 3013 Metals Carrier Assembly (19-A-1254-PATRAM)

Charles McKeel, Juan Licea-Yanez and Glenn Abramczyk
Savannah River National Laboratory

ABSTRACT

The Model 9977 (9977) is a packaging designed to ship radioactive material (RAM) content compliant with Title 10 of the Code of Federal Regulations, Part 71. A new Content consisting of RAM in DOE-STD-3013 (3013) Containers has been added to that currently authorized for shipment in the 9977 Packaging. The Content Shipper has an operational requirement to pre-load two 3013 Containers into a common carrier system. This Carrier System can later be loaded as a unit into the Containment Vessel of the 9977 Packaging; reducing the loading time and the dose-rate exposure of the packaging operators. The performance requirements, design and functionality of the Dual 3013 Carrier System is discussed in this paper.

Introduction

The Model 9977 (9977) is a radioactive material (RAM) Title 10 of the Code of Federal Regulations, Part 71 Type B compliant packaging that was first certified for use by the Department of Energy Office of Environmental Management in October 2007. It was subsequently certified by the National Nuclear Security Administration (NNSA) Office of Packaging and Transportation (OPT), beginning in October 2012. The 9977 is currently certified to ship thirteen different contents in various configurations.

NNSA-OPT has been authorizing new contents within the 9977 through the review and approval of “Changes” to the last certified revision of the Safety Analysis Report for Packaging (SARP). The latest certified version of the 9977 SARP is Revision 2 Change 3 which was approved in July 2018.

Discussion

The latest content needed to be added to the 9977’s authorization consists of two Department of Energy (DOE) Standard 3013 (DOE-STD-3013) (referred to as the 3013) storage containers with plutonium (Pu) metal contents. The 3013 standard permits up to 4.4 kg of Pu metal. The 9977 is already authorized to ship two (2) 3013s with each containing up to 4.4 kg of Pu as oxide. Additionally, the 9977 is authorized to ship up to 4.4 kg of Pu metal. But, the combination of the configuration of two 3013s with Pu metal each loaded to their maximum RAM limit was not yet authorized.

To be as conservative as possible, it is always assumed that the contents are in the most reactive configuration possible, unless there is a verifiable justification against the configuration. The implication of this assumption is that the material reconfigures into the most reactive shape (e.g.

as a hemisphere) and that the separate masses move as close to each other as physically possible in the package as permitted by the configuration. Previous criticality evaluations demonstrated that fissile material contents at masses exceeding the minimum subcritical mass (MSM) limits need to be shipped in a configuration that reduces the diameter of the Containment Vessel (CV) content volume to 5-inches or less. The Dual 3013 Pu Oxide content previously mentioned is shipped in this type of “sleeved” configuration. It was also previously established that the spacer material could not be steel, as steel acts as a reflector increasing the reactivity of the system. Scoping criticality calculations were done which determined that a minimum separation of two Pu metal masses in the axial direction was needed to assure subcriticality of the configuration. The amount of separation needed is dependent upon the content mass. Conversely, increasing the separation distance permits an increase in the mass allowed. It was determined that a “shelf” feature was needed to assure the required separation between the RAM masses and that feature be permanently affixed to the sleeve feature so that it could not be accidentally left out of the loaded configuration.

Finally, there was a desire for the criticality control device to function as an assembly and loading tool. The request was for the Shippers to be able to pre-assemble their contents into the device and then, at time of package loading, place the entire content/configuration into the CV in one step. This functional requirement imposed additional structural design requirements on the device for it to be qualified as a lifting device within the facility.

Subcriticality

As had been demonstrated previously for fissile material content masses greater than the MSM, a 5-inch diameter right-circular cylinder is an inherently subcritical configuration. As the desired content mass was well above the MSM for Pu metal, the Carrier would require a feature to decrease the diameter of the content volume to 5-inches or less. The shape of previously used Pu content “sleeves” (e.g. the “3013 Spacer”) would be used. These designs are known to close fit within the CV and not interfere with the CV lower girth weld.

Previously performed criticality evaluations for generic Pu metal shapes and masses had verified the need for axial separation of the Pu mass to assure subcriticality, i.e. k_{eff} less than or equal to k_{safe} . The required separation distance and the total Pu mass are interdependent. The maximum separation possible based upon geometry of the 3013 Container and the CV interior dimensions was determined. See Figure 1. The Bottom 3013 Container was positioned in contact against the inner surface of the “pipe cap” bottom of the CV. To provide some accommodation for manufacturing tolerances, the Top 3013 Container was positioned 0.1-inches below the bottom surface of the Closure Assembly. Using the maximum 10-inch height of two 3013 Containers, the resulting separation between the Containers is 0.78 inches. This became the design thickness for the “shelf” feature of the Carrier. For conservatism, the shelf was credited in the criticality evaluation at only 0.75-inches thick. The attachment/latch function features of the shelf would have to be accomplished within this thickness.

Again, as in the previous criticality control feature designs, the Carrier would need to be fabricated mostly from aluminum. For criticality evaluations aluminum is essentially transparent to neutrons and is replaced by air or water, depending on the analysis conditions. While steel would be stronger and would better maintain the spacing through the Normal Conditions of Transport (NCT) and the Hypothetical Accident Conditions (HAC) transportation scenarios, steel is a neutron reflector and increases the system reactivity. The amount of steel used would be specifically analysed and minimized in the final design.

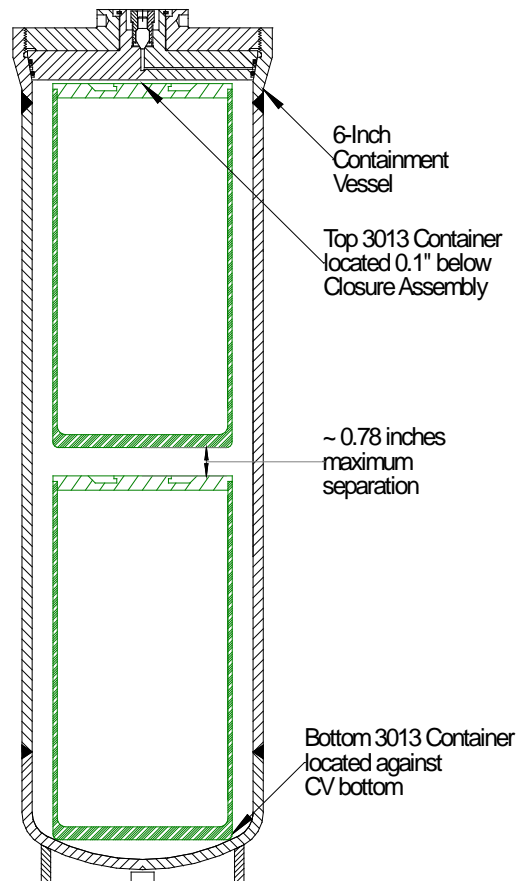

Figure 1 – CV Spacing

In order to maximize the separation of the Pu masses, and thereby maximize the content mass of Pu permitted, the thickness of the stainless steel lids of the 3013 containers was also credited for providing additional separation distance. The thickness of the 3013 Outer, Inner, and Convenience container lids were used, conservatively assuming that the NCT and HAC accidents caused complete collapse of the lids, and with the 3013 Containers arranged with their tops oriented together (i.e. one 3013 must be loaded up-side down). This configuration is shown in Figure 2 and the separation distance shown in detail in Figure 3.

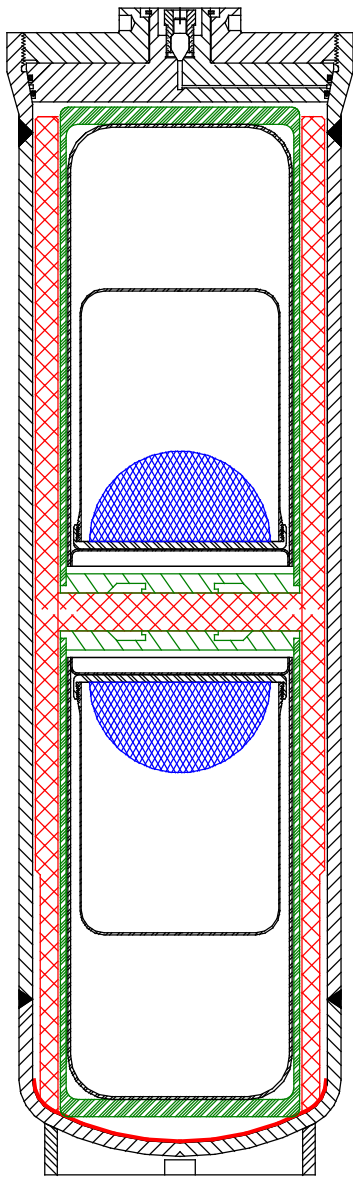
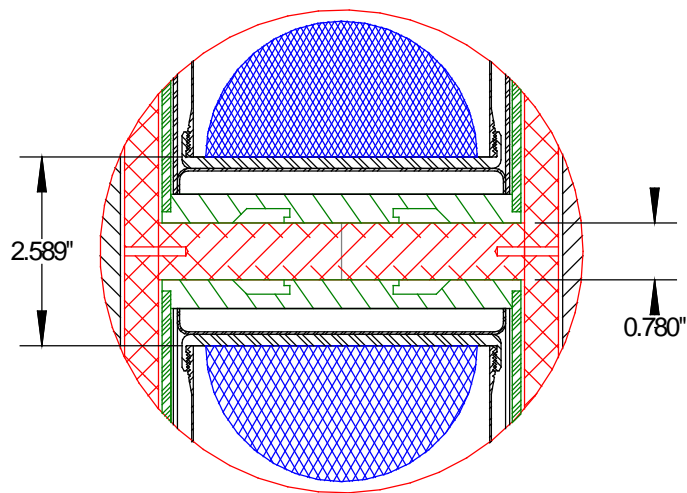

Figure 2 – 3013 Carrier Loading



Pre-HAC Configuration (above)

Post-HAC Configuration (below)

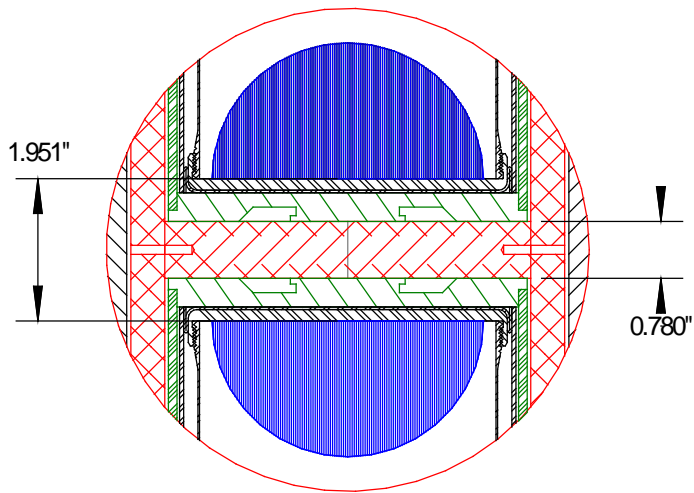

Figure 3 – Minimum Content Separation

Assembly and Loading

The Carrier was to be made primarily of aluminum for strength, criticality control and minimum weight. A limited amount of steel could be used for high load bearing/stress components needed to meet performance requirements. A method was needed for attaching the Bottom 3013 Container to the Carrier and for lifting the 3013. The design of the Latches was loosely based upon an existing hand grapple which interfaces with the “handling feature” incorporated into the lid of the Outer 3013 Container. The desire was for the Latches to operate manually, to engage the handling feature, not require any springs to either latch or un-latch, to be easy to operate with no or minimal tools, and to incorporate a positive “locking” feature. The Carrier was also to be easy and safe to load and assemble. The subcriticality based need to load the Top 3013 Container “up-side down”

complicated the operational requirements and the Carrier design. The 3013 Containers may each weigh up to 20 pounds, contain up to 19 watts of decay heat, and are smooth on all surfaces (with the exception of the handling feature in its lid). The loading requirements for the Top 3013 Container into the Carrier was to be as simple and hazard-free as possible. The assembled Carrier would be evaluated at its maximum weight to the operating facilities' safety basis requirements for lifting. The Carrier is also required to be structurally sound in and after the NCT and HAC accident events. Once loaded into the 9977, the Latch feature is no longer an operational desire and it is not a safety basis requirement. So, while the Carrier is not required to remain latched to the Bottom 3013 Container in an accident, the sleeve feature is not permitted to thin radially, and the shelf feature is not permitted to thin axially to less than the thicknesses credited in the Criticality evaluation.

Final Design

The final design for the 3013 Carrier is shown in Figure 4. Details of the latching mechanism are shown in Figure 5. The Carrier is approximately 99% aluminum with the Latches being the only steel components. The attachment system for the Bottom 3013 consists of two Latches that are captured radially between a central circular Hub and an oval cam hole in the shelf. The Hub has horizontal grooves in the bottom surface of its top plate that capture matching plates in the Latches. Rotation of the Hub about the axis of the Carrier forces the Latches to also rotate about this axis while still free to translate radially in the Hub top plate groove. See Figure 6 for depictions of the Latch operation. Turning the Hub into the "Latched" position causes the Latches to move inward axially by forcing vertical semi-circular bearing surfaces to press against the vertical oval cam surface of the shelf. The bottom horizontal plates of the Latches have semi-circular cutouts which fit within the handling feature in the lid of the Bottom 3013 Container. The top horizontal plate of the Latch has a Spring Plunger which serves a dual purpose. The detent tip of the plunger engages with recesses in the Shelf Plate when the Hub/Latches are turned to the "Latched" position. The Detents inhibit vibration from causing rotation of the Hub, movement of the Latches, and disengagement of the Latches from the 3013 handling feature. The body of the Detent extends through and below the top horizontal plate and rides in an oval groove in the top of the shelf. Rotating the Hub from the Latched to the "Unlatched" position, overcoming the resistance of the Detents, forces the body of the Detents to cam outward in the oval groove and move the Latches axially outward from the center. This axial motion of the Latches causes them to disengage from the 3013 handling feature. A Shelf Plate is fixed to the Shelf with four aluminum screws. The Shelf Plate centers the Hub and captures the Latches between the Hub and the Shelf. The Hub has a central standard 1/2-inch square drive socket for actuation.

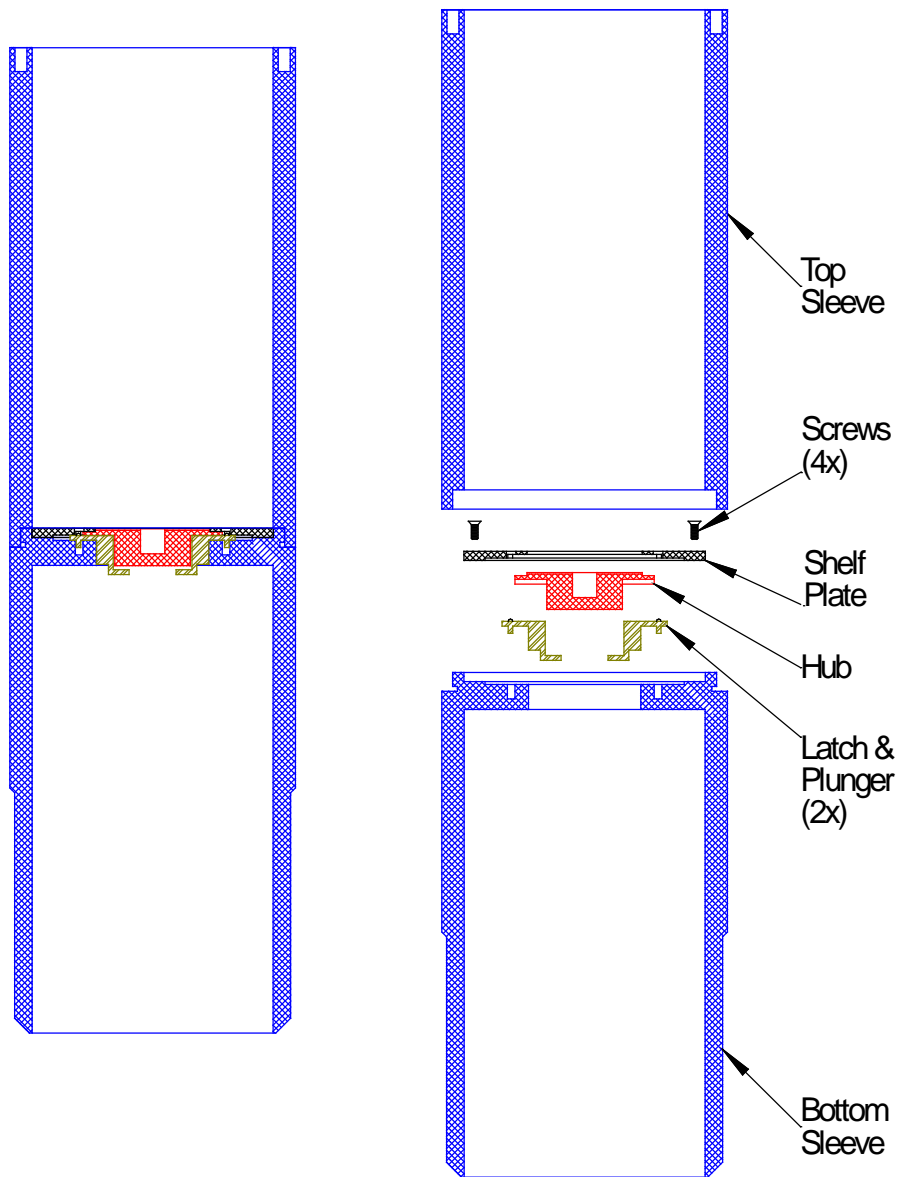

Figure 4 – 3013 Carrier Design

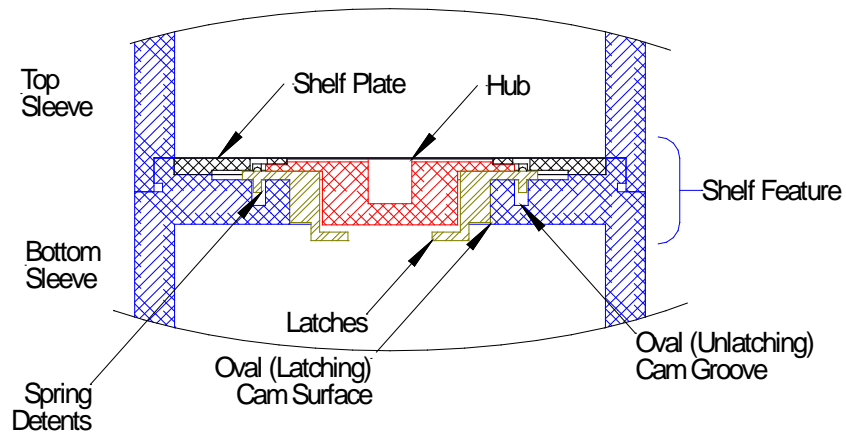

Figure 5 – 3013 Carrier Latch Detail

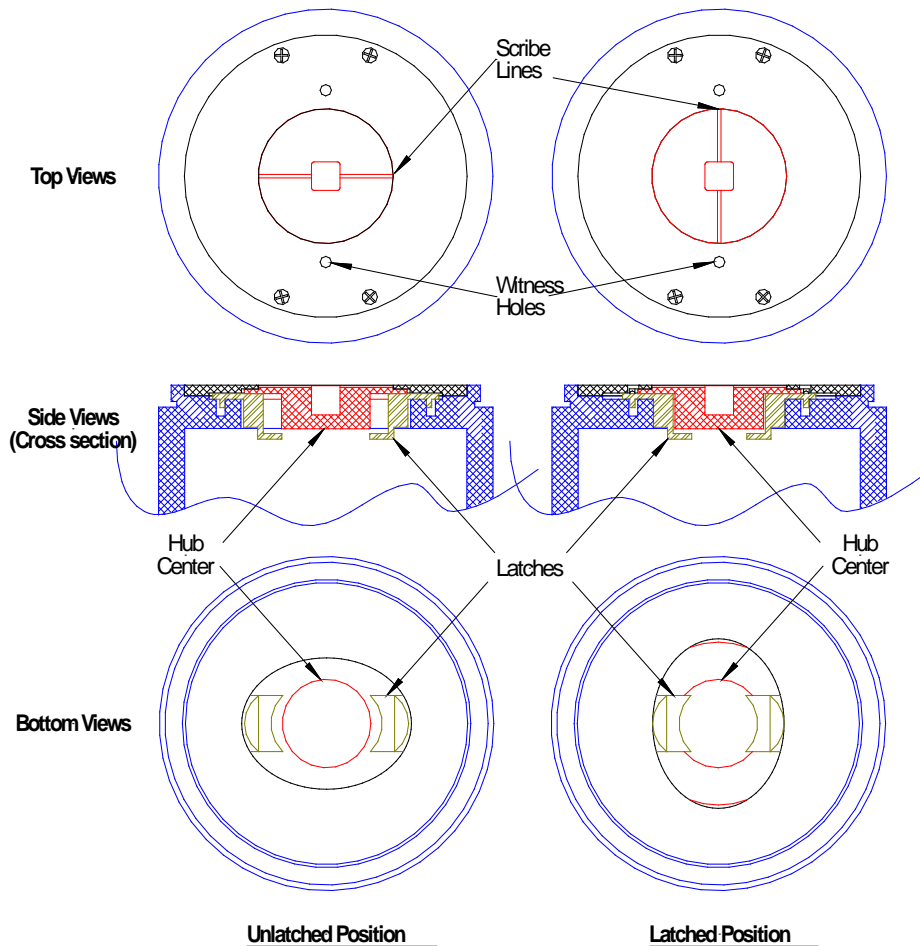

Figure 6 – 3013 Carrier Latch Function

The “sleeve” feature is split essentially in half into two tubes which thread together. Separating the sleeve into two components make it easier to load the two 3013 Containers. The Bottom Sleeve with the shelf feature and the latch system is slightly more than half of the Carrier’s 17 lb weight.

The lighter Bottom Sleeve can be placed over and latched to the Bottom 3013 Container. There is also easier access to the drive socket without the Top Sleeve present. The Top 3013 Container is then inverted and placed directly onto the Shelf feature. Were the Top Sleeve an integral component with the Bottom, the Top 3013 Container would have to be lowered into the sleeve. With the 3013 Container being heavy, hot, and smooth, designing a tool or fixture to safely perform this operation would have been challenging. Dropping the Top 3013 Container would be a real possibility. With the Top 3013 Container emplaced, the Top Sleeve is simply placed over it and threaded onto the Bottom Sleeve. Finally, the top edge to the Top Sleeve has two threaded holes for the attachment of a lifting handle. The lifting handle is structurally qualified to lift the 3013 Carrier Assembly with two maximum weight 3013 Containers.

Conclusion

Savannah River National Laboratory is in the processing of certifying the Model 9977 Packaging with a new RAM Content consisting of two DOE-STD-3013 Containers containing plutonium metal. SRNL has designed a 3013 Carrier device which has the capability to pre-load two 3013 Containers into a “carrier assembly”. This Carrier Assembly can pre-assembled and later be loaded as a unit into the Containment Vessel of the 9977 Packaging. This would reduce the loading time and the dose-rate exposure of the packaging operators. In shipment safety space, the 3013 Carrier also functions as a criticality control device permitting a greater mass of radioactive contents by maintaining its separation in all Normal Conditions of Transport and in the Hypothetical Accident Conditions.