

6018 Integrity of 30B cylinder plug for physical contact

Hiroshi Takahashi

Mitsubishi Nuclear Fuel Co., Ltd.

Suguru Hode

Mitsubishi Nuclear Fuel Co., Ltd.

Junichi Kishimoto

Mitsubishi Heavy Industries, Ltd.

Takayuki Hase

Mitsubishi Heavy Industries, Ltd.

Abstract

Compression test and helium leakage test were conducted using test specimens simulated a plug of 30B cylinder.

This compression test was carried out for three angles (0° , 24° and 90° against the axial direction of the plug) until the plug threads failed, and leakage rate was measured. Test results showed that plug threads failed at 310 to 360 kN of load in 0° and 24° direction. However, in both cases, the leakage rate of the plug was maintained at 1×10^{-7} Pa·m³/sec SLR or less even after the plug threads failed. In the case of load in 90° direction (i.e., load from side of plug), the leakage rate of the plug was maintained less than 1×10^{-9} Pa·m³/sec SLR until 110 kN of load was imposed, but the plug threads failed and leakage occurred at 125 kN of load.

In addition, a thermal evaluation was also conducted assuming that the plug was in contact with an overpack. This result showed that integrity of the plug could be maintained even if the plug was in contact with an overpack in the event of the thermal test under the accident conditions of transport.

Introduction

30B cylinders are used for transportation of uranium hexafluoride (UF₆) enriched to 5% or less. The 30B cylinder is specified in ANSI N14.1 ^[1] or ISO 7195 ^[2], and it is normally shipped by being contained in an outer protective packaging called overpack.

As shown in Figure 1, the 30B cylinder has a valve and a plug. According to the current IAEA regulations for the safe transport of radioactive material (SSR-6) ^[3], it is required that there is no physical contact between the valve and any other component of the packaging under the accident conditions of transport (ACT).

Recently, it is discussed that the plug also should be prohibited from contacting out of concern that physical contact between the plug and the overpack could affect the containment integrity of it. It might be regularized in the near future.

On the other hand, there are not so many examples which discussing about the ability of the plug integrity for physical contact. Regardless of whether no physical contact of the plug is to be

regularized or not, it is important to understand the containment ability of the plug for physical contact.

Here, in this paper, integrity of the plug for physical contact is studied by conducting a compression test of the plug and a thermal evaluation assuming the plug makes contact with an overpack during the thermal test in ACT.

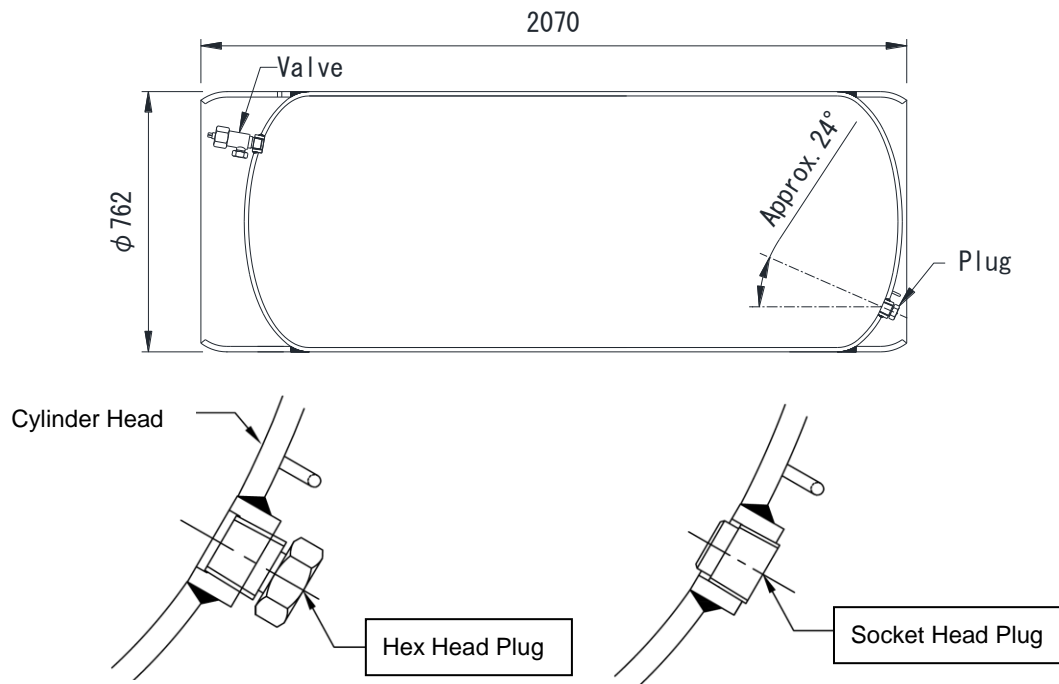

(Note) The angle of 24° is estimated by drawing. (Not specified in ANSI N14.1 / ISO 7195)

Figure 1. 30B cylinder and plug

Compression and Leakage Test

Compression test and leakage test were conducted using test specimens simulated the plug of 30B cylinder in order to confirm the containment ability of the plug for physical contact.

Test specimen

A picture of the test specimen is shown in Figure 2. The test specimen used for this compression test is a partial model of the plug parts of 30B cylinder. Specification of the plug and the coupling is the same as used for the actual 30B cylinder. The type of the plug is “Hex head plug”. The thread part of the plug is tinned in accordance with ANSI N14.1. The coupling is welded to a flat steel plate instead of a cylinder head.

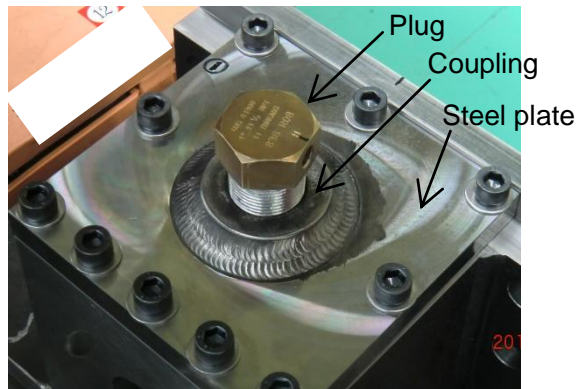

Figure 2. Appearance of the test specimen

Overview of plug compression and leakage test

An outline diagram of the test equipment used in this test is shown in Figure 3. A load is imposed on the plug of the test specimen with a pressing machine through a load cell, and an amount of leak from the plug is measured with a helium leak detector.

This test was carried out for three angles; axial direction (0°), inclination direction (24°) and lateral direction (90°) of the plug. The angle of 24 degrees is the same as the angle that a plug is installed in 30B cylinder. (See Figure 1)

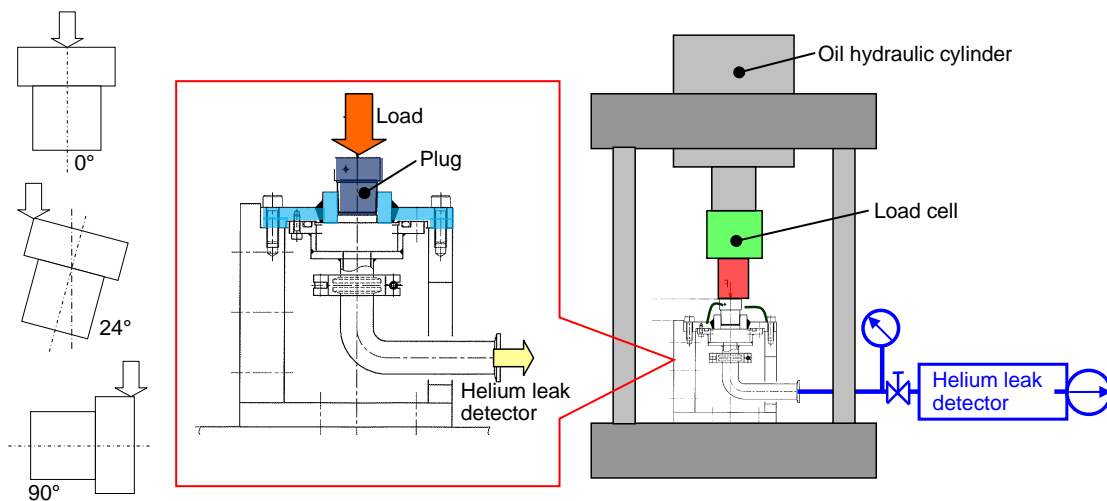

Figure 3. Outline diagram of the test equipment

Test conditions

(1) Load conditions

The load imposed on the plug (test specimen) is increased by 10kN each step until the plug threads fail. In each step, the load is once unloaded prior to proceeding to the next load condition in order to confirm the leakage rate under unloading conditions. (See Figure 4)

(2) Measurement conditions of leakage rate

Leakage rate of the plug is measure by Gas filled envelop method using helium as tracer gas. Measurement of the leakage rate is conducted in both conditions of loading and unloading.

(3) Engagement condition of the plug threads

The engagement conditions between the plug and the coupling are shown in Table 1.

All plugs are installed in the coupling so as to be near 5 threads engagement taking into account the minimum engagement of 5 threads specified in ANSI 14.1 and ISO 7195 for the Hex head plug.

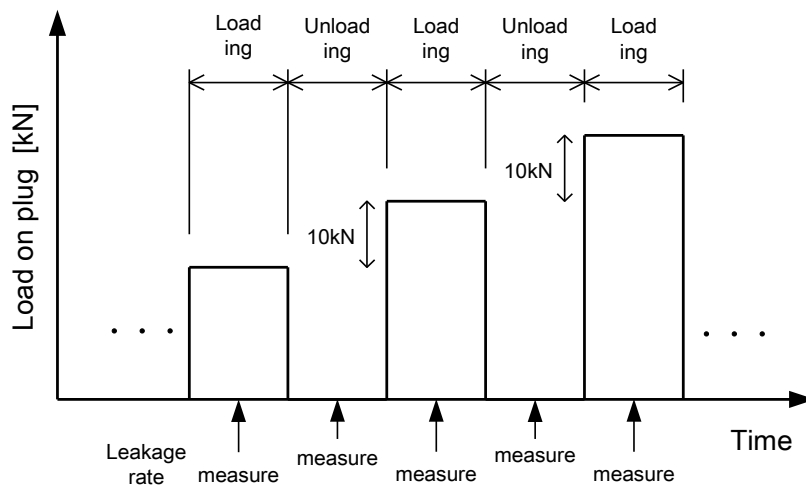

Figure 4. Loading on the plug

Table 1. Engagement condition of plug threads

Test Case		Screwed number of plug to coupling ^(a)
axial direction (0°)	1-1	5.125
	1-2	4.75
Inclination direction (24°)	2	4.25
Lateral direction (90°)	3	5.25

(a) The plug thread engagement is specified as 5 minimum in ANSI N 14.1 and ISO 7195.

Plug compression test results

The test results of the compressive and leakage tests are shown in Table 2. The leakage rate of the specimens measured before the compressive test was less than $1 \times 10^{-9} \text{ Pa} \cdot \text{m}^3/\text{sec SLR}$ in all cases.

In case 1 (compression test in the axial direction of the plug (0°)), the test was conducted using two specimens. In both specimens, the integrity of the plugs was maintained until 350kN of the load. When the load was increased to 360kN, shear fracture occurred at the threads of the plug. However, the leakage rate of the plug has been maintained less than $1 \times 10^{-9} \text{ Pa} \cdot \text{m}^3/\text{sec SLR}$ even after the plug threads failed. The pictures of the plug after the plug threads failed are shown in Figure 5. The cross section which was cut after the test was shown in Figure 6.

In case 2 (compression test in 24° direction against the axial direction of the plug), the test was conducted using one specimen. The integrity of the plug was maintained until 300 kN of the load. When the load of 310kN was applied, shear fracture occurred at the threads of the plug. The leakage rate of the plug was maintained less than $1 \times 10^{-9} \text{ Pa} \cdot \text{m}^3/\text{sec SLR}$ before plug threads failed. After the plug threads failed, the leak rate of the plug slightly increased, but it was about $1 \times 10^{-7} \text{ Pa} \cdot \text{m}^3/\text{sec SLR}$. The pictures of the plug after the plug threads failed are shown in Figure 5. The cross section is shown in Figure 7.

In case 3 (compression test in lateral direction of the plug (90°)), the test was conducted using one specimen. The leakage rate of the plug was maintained less than $1 \times 10^{-9} \text{ Pa} \cdot \text{m}^3/\text{sec SLR}$ until 110 kN of the load. The leakage rate started increasing at 120 kN, and when the load was increased to 125 kN, shear fracture occurred at the threads of the plug. The leakage rate after the plug failed was over $3.7 \times 10^{-4} \text{ Pa} \cdot \text{m}^3/\text{sec SLR}$. The pictures of the plug after the plug threads failed are shown in Figure 5.

Table 2. Compression test results

Test Case		Initial leakage rate [$\text{Pa} \cdot \text{m}^3/\text{sec SLR}$]	Load when plug threads failed [kN]	The leak rate before/after the plug threads failed [$\text{Pa} \cdot \text{m}^3/\text{sec SLR}$]		
Axial direction (0°)	1-1	$< 1.0 \times 10^{-9}$	360	before and after fracture $< 1.0 \times 10^{-9}$		
	1-2		360			
Inclination direction (24°)	2		$< 1.0 \times 10^{-9}$	310	before fracture $< 1.0 \times 10^{-9}$	
					after fracture = about 1.0×10^{-7}	
Lateral direction (90°)	3			$< 1.0 \times 10^{-9}$	125	before fracture $< 1.0 \times 10^{-9}$ (a)
						after fracture $> 3.7 \times 10^{-4}$

(a) Leakage rate was increased to $1.1 \times 10^{-5} \text{ Pa} \cdot \text{m}^3/\text{sec SLR}$ when 120 kN of load was unloaded.



before test (Case 1-1)



Axial direction load (0°)

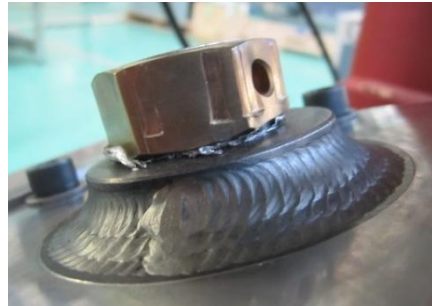

Inclination direction load (24°)



Lateral direction load (90°)

Figure 5. Failed plug after compression test

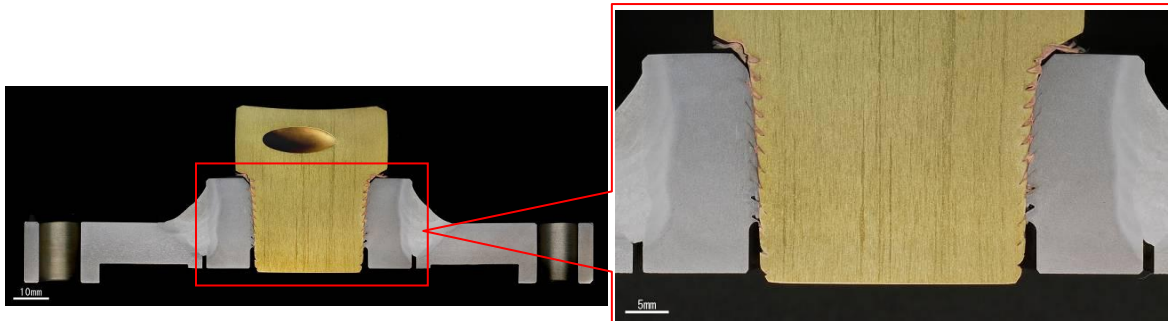

Figure 6. Cross Section of Plug (Compression in axial direction (0°))

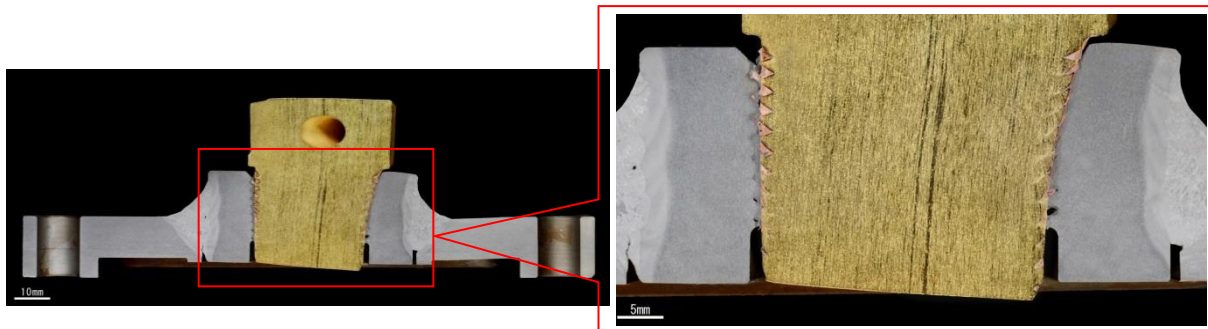

Figure 7. Cross Section of Plug (Compression in inclination direction (24°))

Plug Integrity in Thermal Test of ACT

A thermal evaluation was conducted in order to confirm the integrity of the plug when it contacts an overpack in the event of the thermal test under ACT.

Calculation model and conditions

- MST-30 overpack is used in this evaluation
- Damage of the overpack caused by drop tests was conservatively assumed
- Mass of UF_6 is assumed to be 0 kg (empty)
- Following parts are thermally connected using fully large heat transfer coefficient (See Figure 8)
 - Plug – Overpack
 - Cylinder Head – Overpack (Area of $\phi 320\text{mm}$)

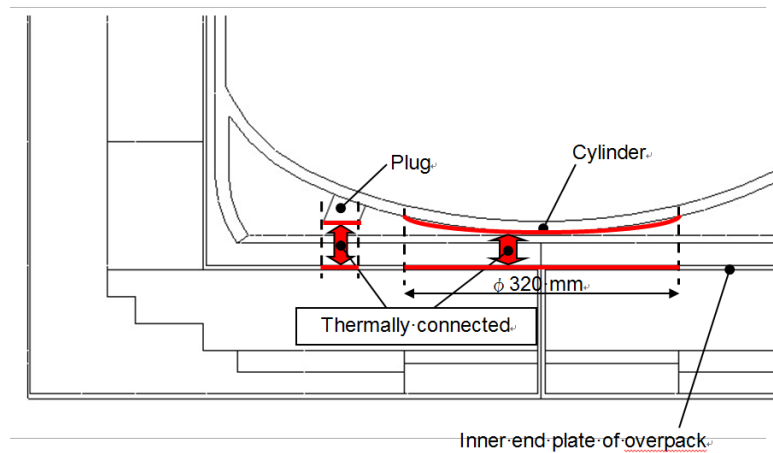

Figure 8. Thermal connection between plug / cylinder head and overpack

Calculation Results

The thermal evaluation result is shown in Table 3. The maximum temperature of the plug is 127 °C, which is well below the melting temperature of the solder tinned on the plug threads (183 °C). Thus, integrity of the plug is maintained without the solder melting by thermal even if the plug is in contact with an overpack during thermal test in ACT.

Table 3. Thermal evaluation result and criterion

	Calculation Result (maximum temp. of plug)	Criterion (melting point of solder)
Temperature of plug	127 °C	183 °C

Discussion

A summary of the compression test and thermal evaluation results is as follows.

- Plug threads failed at 360 kN of load in 0° direction (axial direction of the plug) and 310 kN of load in 24° direction (the same angle as the plug is installed in 30B cylinder). However, in both cases, the leakage rate of the plug was maintained at about 1×10^{-7} Pa·m³/sec SLR or less both of before and after the plug threads failed.
- In the case of the load in 90° direction (load from side of plug), the leakage rate of the plug was maintained less than 1×10^{-9} Pa·m³/sec SLR when the load on the plug was 110 kN or less. The leakage rate started increasing at 120 kN, and the plug threads failed at 125 kN. The leakage rate after plug failed was over 3.7×10^{-4} Pa·m³/sec SLR.
- Even if the plug is in contact with an overpack during thermal test in ACT, integrity of the plug is maintained without solder on the plug threads melting.

Hereinafter, we will discuss the above results.

(1) Containment integrity of plug

When a plug is installed in 30B cylinder, no leakage of the plug is confirmed by air soap bubble test, which sensitivity is equivalent to 1×10^{-4} Pa·m³/sec SLR [4].

Assuming the criteria for leaktightness of the plug to be this value, in the case of the load in 0° and 24° directions, leaktightness of the plug is maintained even if the plug threads fail. In the case of the load in 90° direction, leaktightness of the plug can be maintained for up to about 120 kN.

(2) Plug condition after threads failed

In the case of load in 0° and 24° directions, the leakage rate of the plug was maintained at about 1×10^{-7} Pa·m³/sec or less after the plug threads failed. As shown in Figure 5, the plug threads fractured in the shape that they were pressed into the coupling. In this type of fracture, containment ability of the plug could be maintained due to the solder on plug threads gets through the gap between the plug and the coupling.

On the other hand, in the case of the load in 90° direction, the plug was not pressed into the coupling. The plug failed by pull out force due to moment as shown in Figure 5.

(3) Plug integrity for physical contact in accident

As the result of the compression test, the severest direction of load for the plug is the lateral direction (90°) of the plug. However, there are skirts in both sides of 30B cylinder and the plug is protected by the skirt. So, it is hard that load acts on the plug from side direction actually unless the cylinder skirt deforms largely due to drop impact.

In the case of the load in 0° and 24° directions, the test result shows integrity of the plug can be maintained for the load up to about 300 kN. Here, assuming that the direction of load acting on the plug due to contact is the same as drop direction simply, this test result means containment integrity of the plug is maintained in drop orientations from vertical (0°) to 48° of angle including corner drop, even if the load up to 300 kN acts on the plug.

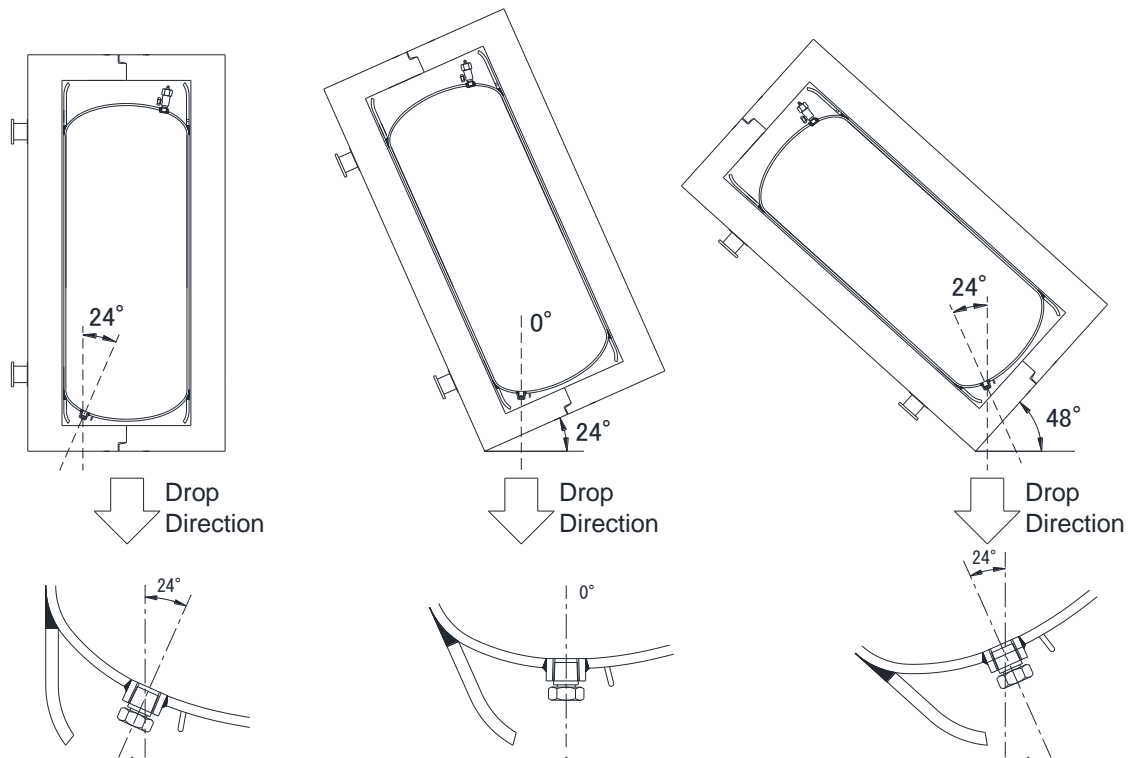

Figure 9. Relation between Plug Angle and Drop Direction

(4) Socket Head Plug

In this paper, the compressive test was conducted using Hex Head Plugs, but another type of plug “Socket Head Plug” is also specified in ANSI N14.1. This Socket Head Plug could be protuberant by three threads (about 6.6 mm) in maximum from the surface of the coupling when it is installed in accordance with ANSI N14.1. Since specification of the threads is the same between Socket Head Plug and Hex Head Plug, the compression test result in this paper can be applied for the Socket Head Plug.

In addition, since protuberance of Socket Head Plug is slight, a load from side of the plug does not occur. It would be a load almost in axial direction of the plug.

Conclusions

Compression test and helium leakage test were conducted using test specimens simulated a plug of 30B cylinder. This test was carried out for three angles (0°, 24° and 90° against the axial direction of the plug) until the plug threads failed, and leakage rate was measured. Test results showed that plug threads failed at 360 kN of load in 0° direction and 310 kN in 24° direction. However, in both cases, the leakage rate of the plug was maintained at 1×10^{-7} Pa·m³/sec or less before and after the plug threads failed. In the case of the load in 90° direction (i.e., load from side of plug), the leakage rate of the plug was maintained less than 1×10^{-9} Pa·m³/sec until 110 kN of load was imposed, but the plug threads failed and leakage was occurred at 125 kN of load.

Judging from the test results, the severest load for the plug is a load in lateral direction (90°). However, since the plug of 30B cylinder is protected by the cylinder-skirt, it is hard that load acts on the plug from side direction (90°) actually unless the cylinder skirt deforms largely due to drop impact. On the other hand, simply assuming that the direction of load acting on the plug due to contact is the same as drop direction, this test result means integrity of the plug is maintained in drop orientations from vertical (0°) to 48° of angle including corner drop, even if the load up to 300 kN acts on the plug.

Furthermore, a thermal evaluation was also conducted assuming that the plug was in contact with an overpack. As the result, integrity of the plug can be maintained without melting of the solder on the plug threads even if the plug is in contact with an overpack in the event of the thermal test under the accident conditions of transport.

In addition, this test was conducted using Hex Head Plug, but this test result also can be applied for the Socket Head Plug when it's protuberant (max. 3 threads as specified in ANSI N14.1-2012) makes contact with an overpack.

References

- [1] ANSI N14.1-2012, "American National Standard for Nuclear Materials – Uranium Hexafluoride – Packagings for Transport"
- [2] ISO 7195-2005, "Nuclear energy – Packaging of uranium hexafluoride (UF₆) for transport"
- [3] No. SSR-6, "Regulations for the Safe Transport of Radioactive Material, 2012 Edition"
- [4] ISO 12807-1996, "Safe transport of radioactive materials – Leakage testing on packages"