

Paper No. 4045

**Testing of the Authenticatable Container Tracking System (ACTS)<sup>1</sup>**

**Charles Britton, Chris Pickett,  
James Younkin, Shane Frank,  
Scott Stewart, Dan Floyd,  
Andrzej Nycz, Richard Willems**  
Oak Ridge National Laboratory  
Oak Ridge, TN, USA

**James Shuler**  
Packaging Certification Program  
U.S. Department of Energy, USA

**Yung Liu, Brian Craig**  
Argonne National  
Laboratory  
Lemont, IL, USA

**Daniel Krementz**  
Savannah River National  
Laboratory  
Aiken, SC, USA

**Ethan Farquhar**  
Pacific Northwest National  
Laboratory  
Richland, WA, USA

**Abstract**

The Authenticatable Container Tracking System (ACTS) is being designed to provide a secure container tag that can be used to optimize chain-of-custody monitoring for packaged nuclear materials as they are being stored, processed, and transported. ACTS is an active device that uses a universal core platform that can be appropriately configured to provide the necessary data acquisition, data logging, and communications functions needed for 21st century material accountancy, monitoring, and tracking applications. The core design supports active monitoring of containment, movement, and location and provides secure data transmission via selectable communication methods such as Iridium and GSM cellphone that can be used throughout the world. This core architecture enables appropriately designed modules to be easily interfaced to the basic system, thus providing an integration path for current and new technologies. ACTS contains a built-in set of sensors but also supports an expansion bus for up to six additional communications, tracking, or sensing modules that may enhance monitoring and tracking of particular containers for specific applications. ACTS stores events in memory, communicates activity to Argonne National

---

<sup>1</sup> This manuscript has been authored by UT-Battelle, LLC, under Contract No. DE-AC0500OR22725 with the U.S. Department of Energy. The United States Government retains and the publisher, by accepting the article for publication, acknowledges that the United States Government retains a non-exclusive, paid-up, irrevocable, world-wide license to publish or reproduce the published form of this manuscript, or allow others to do so, for the United States Government purposes. The Department of Energy will provide public access to these results of federally sponsored research in accordance with the DOE Public Access Plan (<http://energy.gov/downloads/doe-public-access-plan>).

Laboratory's ARG-US TransPort tracking and information server, and provides options for data encryption and authentication. We are currently beginning a testing phase that will field five devices outdoors to allow evaluation of the functionality of the systems, system reliability, and the robustness of the devices while in outdoor conditions. Partners for this system are Oak Ridge National Laboratory, Argonne National Laboratory, Savannah River National Laboratory, Pacific Northwest National Laboratory, and commercialization partner The Aquila Group.

## Introduction

We previously reported on the new Authenticatable Container Tracking System (ACTS) [1]. The ACTS concept is to provide an almost-universal platform, compatible with Argonne National Laboratory's ARG-US TransPort tracking and information server, for active monitoring of device containment and device location and report status at regular intervals via the chosen communication method. ACTS will also provide its own battery power and will store events in memory. ACTS is planned to incorporate a universal interface architecture that will enable future modules to be easily interfaced to the basic system, thus providing an integration path for new technologies. Modules currently under development for this system include Global Positioning System (GPS), a smaller-footprint DW1000 radio board, and an Iridium satellite communications board. Partners for this system are Oak Ridge National Laboratory, Argonne National Laboratory, Savannah River National Laboratory, Pacific Northwest National Laboratory, and commercialization partner Aquila.

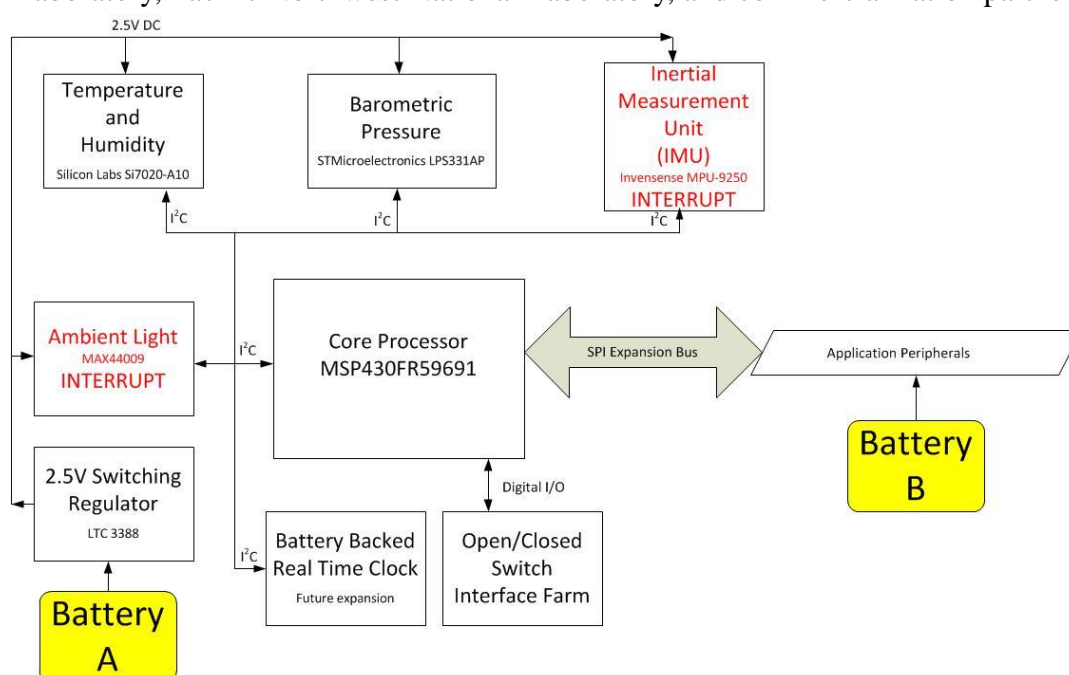
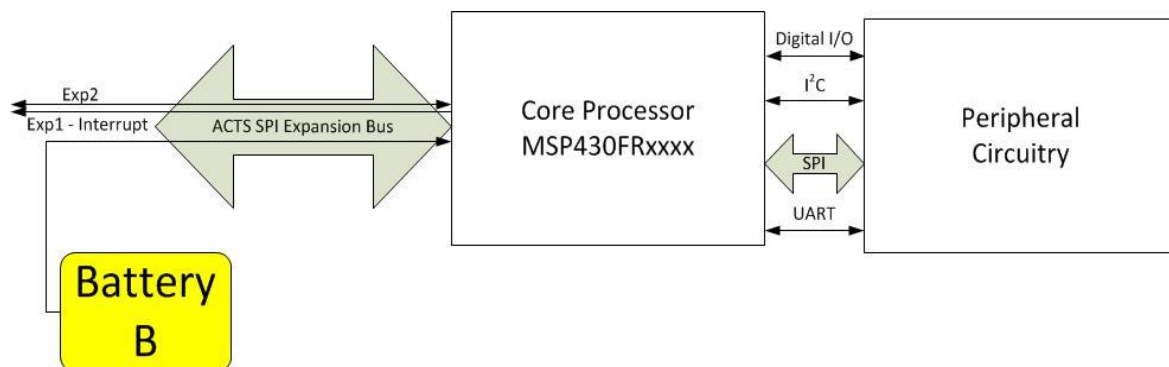

**Figure 1. The ACTS Motherboard Architecture, built on the low-power MSP family of processors, incorporates a base set of relevant sensors and a peripheral interface for matching ACTS to specific applications.**



**Figure 2. ACTS test units incorporate the DecaWave EVK 1000 Ultra-wideband module to perform IEEE 802.15.4-2011 communications.**

The present version of the ACTS architecture is shown in Figure 1. It consists of onboard dedicated environmental monitors (temperature, pressure, humidity, and light) and a 9-axis micro-electro-mechanical-system Inertial Measurement Unit which consists of an accelerometer, gyrometer, and magnetometer. The motherboard has its own dedicated battery which powers only the motherboard processor and the resident sensors. The single peripheral in the picture of the upper part of system shown in **Error! Reference source not found.** is the DecaWave EVK1000 ultra-wideband



**Figure 3. Using a processor in the peripheral reference design allows interfacing flexibility and commonality among the peripherals.**

(UWB) radio which is used for communication between the ACTS tags and the base stations. The interface bus consists of six dedicated serial-peripheral-interface (SPI) connectors that allow additional modules to be connected to the motherboard, and the bus also implements a ‘bring-your-own-battery’ (BYOB) concept as shown in Figure 3. BYOB allows the chosen peripheral package to allow sizing of a battery independent from the motherboard battery, thus optimizing system size. In the current design, although the peripherals attached through the SPI connectors have

their own dedicated battery, in future designs each peripheral could have its own individual dedicated battery which would be selected to optimize system size while meeting the power requirements for the specific deployment scenario.

### Peripherals

A key feature of ACTS is the ability to incorporate the “peripherals” (such as communications, GPS, or other sensor packages) needed to support the Concept of Operations and meet the regulatory requirements for a variety of applications. This interoperable design means that the same base hardware and software in an ACTS tag could be fairly easily reconfigured from one application that requires the use of a cellular network with GPS locations, an active seal, and radiation sensors to another application that needs large local data storage with encryption and additional sensors with no communication off the tag by changing the peripheral module loadout in the ACTS enclosure and modifying the motherboard software. The peripheral classes for ACTS, shown in Table 1, consist of modules that provide communications, data storage and security, additional sensors, containment monitoring and location services. A container tracking application that requires the use of a cellular network with GPS locations and requires an active seal and radiation sensor would incorporate the relevant peripherals within the ACTS enclosure. The peripheral modules are based on a reference design that includes their own Texas Instruments MSP430 processor. The peripheral processor allows the details of the peripheral to be abstracted away from the motherboard processor. A common peripheral software interface allows the motherboard to determine the peripheral type and to communicate with the peripheral through a common set of registers and commands (e.g., read, write, status, identity, and configure).

**Table 1 Peripheral Options**

<b>Communications</b>	<b>Data Storage and Security</b>	<b>Additional Sensors</b>	<b>Containment Monitoring</b>	<b>Location Services</b>
Cellular-3G, LTE	Micro SD Card	Gamma	Active Fiber Seal	GPS
Iridium	Smart card hardware security module	Neutron		UWB Indoor Location
UWB				Nearest Neighbors
Wi-Fi				

## Testing

Testing of the ACTS modules is ongoing and includes a variety of both functional and environmental monitoring outdoors and indoors. The testing has initially focused on functionality of the built-in sensors and the software/firmware used to drive them. Drivers had been written for the various devices during development of the system and then modified as the testing proceeded to correct and improve the performance. Development, testing, and refinement are being performed iteratively.

The ACTS test units incorporate a DecaWave EVK1000 UWB module to perform IEEE 802.15.4-2011 communications with base stations connected to PCs. The same UWB modules used in the tags are used as receivers in the base stations. ACTS tags communicate with the base stations using a variety of message types indicated by a flag. The base station interprets these messages and then sends the information to a connected PC over Universal Serial Bus (USB) using a serial port. A custom data application on the PC listens on the serial line, extracts the sensor data, and can write the sensor data to an SQL data format, an ASCII file, and/or it can repackage the data into messages to send to Argonne National Laboratory's ARG-US TransPort tracking and information server as shown in Figure 4.

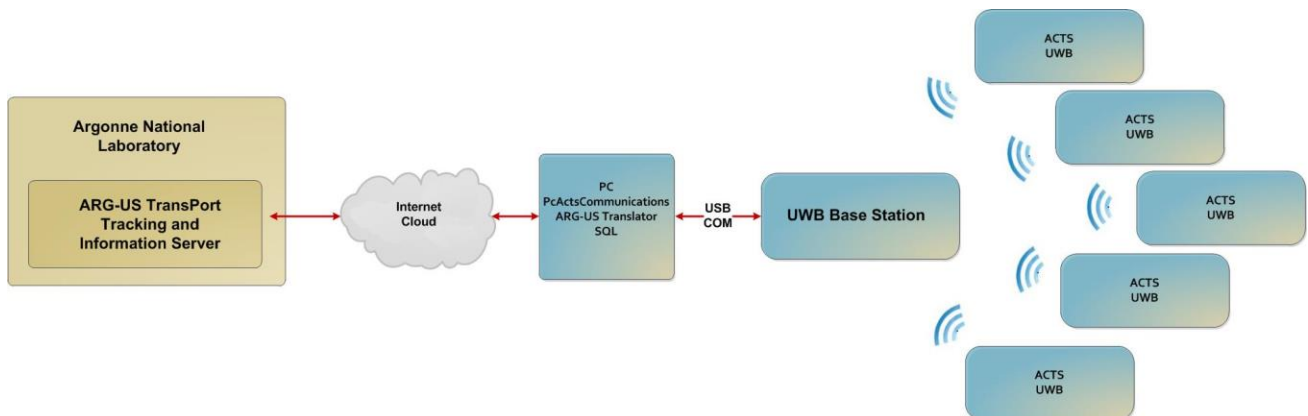

**Figure 4. The testing hardware configuration used five different tags and various servers that collected ACTS messages.**

## ARG-US Testing

The ARG-US system was developed by Argonne National Laboratory for the U.S. Department of Energy (DOE) Packaging and Certification Program to use in managing sensitive nuclear and radioactive materials [2]. Per Figure 4, ACTS data from several tags were relayed to the ARG-US Transport and Information server at Argonne National Laboratory. ACTS messages that included humidity, temperature and barometric pressure data, received via the local wireless base station, were repackaged as JavaScript Object Notation messages and transmitted to the ARG-US server. The interface for viewing these data, as well as location information for the tag, can be seen in Figure 5.

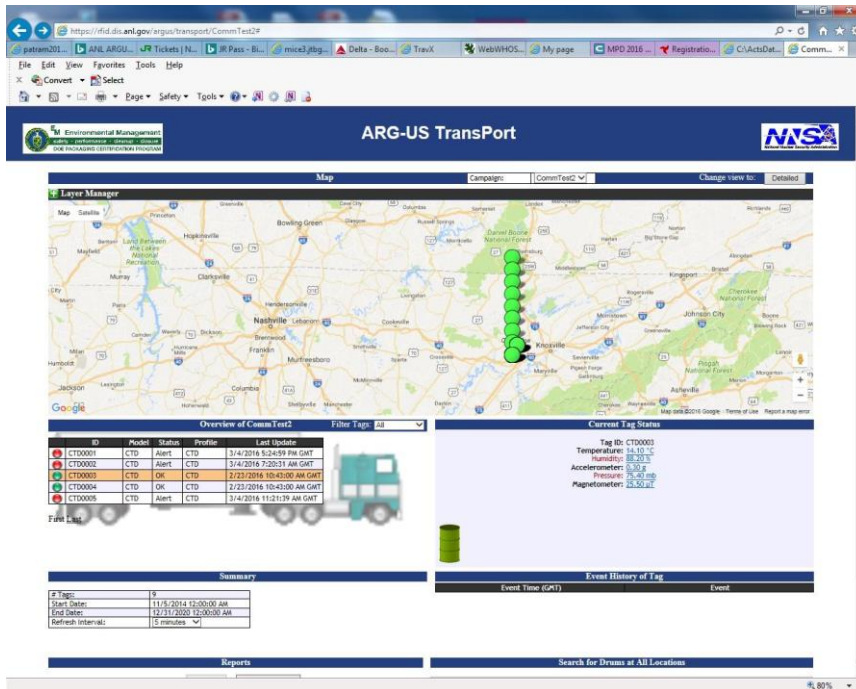

Figure 5. ACTS data were transmitted to the ARG-US TransPort Server.

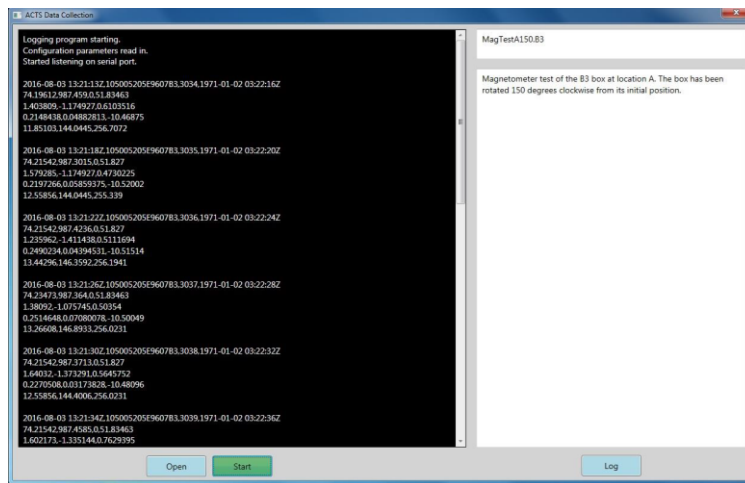

Figure 6. ACTS messages received at a local base station are displayed and archived in an SQL database.

Id	PcListenerDate Time	TagEuid	Temperature	Pressure	Light	Humidity	GyroX	GyroY	GyroZ	AccelerometerX	AccelerometerY	AccelerometerZ	MagnetometerX	MagnetometerY	Mag	
6...	6460	2016-03-16 22:53:30.000	104991205E9607C4	58.0763	984.14...	0	45.326...	-0.8...	0.20...	0.98...	-0.9506836	0.152832	0.1982422	7.656258	-86.48842	330
6...	6461	2016-03-16 22:53:49.000	105203205E9606C1	51.87934	985.52...	0	44.258...	-1.1...	1.19...	0.91...	-0.02490234	0.02734375	-1.03418	-50.40057	-421.8931	932
6...	6462	2016-03-16 22:54:11.000	105005205E9607B3	58.38518	983.61...	0	42.999...	-0.5...	1.77...	-0.3...	0.9951172	0.1445313	-0.03955078	148.9339	-387.0862	876
6...	6463	2016-03-16 22:54:12.000	104991205E9607C4	58.03769	984.17...	0	45.349...	-0.9...	0.12...	0.98...	-0.9516602	0.1489258	0.190918	8.190415	-85.58937	331
6...	6464	2016-03-16 22:54:31.000	105203205E9606C1	51.84073	985.90...	0	44.289...	-0.8...	0.87...	0.94...	-0.02783203	0.01953125	-1.016113	-51.28791	-422.0723	932
6...	6465	2016-03-16 22:54:54.000	104991205E9607C4	57.97977	984.31...	0	45.334...	-1.0...	0.03...	0.86...	-0.9467773	0.1489258	0.2055664	8.012362	-83.97108	330
6...	6466	2016-03-16 22:55:13.000	105203205E9606C1	51.78281	985.72...	0	44.342...	-0.9...	0.67...	0.83...	-0.02490234	0.02050781	-1.013184	-52.35271	-422.0723	931
6...	6467	2016-03-16 22:55:35.000	105005205E9607B3	58.28866	983.62...	0	43.007...	-0.7...	1.91...	-0.3...	1.000488	0.144043	-0.04248047	148.2264	-386.7301	876
6...	6468	2016-03-16 22:55:36.000	104991205E9607C4	57.96047	984.20...	0	45.357...	-0.8...	-0.0...	1.19...	-0.9594727	0.1586914	0.2128906	6.587943	-86.84805	330
6...	6469	2016-03-16 22:55:55.000	105203205E9606C1	51.68629	985.77...	0	44.334...	-0.7...	0.73...	0.96...	-0.02636719	0.01171875	-1.013672	-50.22311	-422.4308	931
6...	6470	2016-03-16 22:56:18.000	105005205E9607B3	58.25005	983.64...	0	43.007...	-0.7...	1.64...	-0.4...	1.002441	0.1513672	-0.04882813	147.5188	-386.3739	877
6...	6471	2016-03-16 22:56:18.000	104991205E9607C4	57.88325	984.33...	0	45.349...	-0.8...	0.15...	1.28...	-0.9501953	0.1586914	0.2016602	7.478206	-87.02785	331
6...	6472	2016-03-16 22:56:38.000	105203205E9606C1	51.7249	985.59...	0	44.3273	-1.0...	0.67...	0.90...	-0.01513672	0.01757813	-1.013184	-49.86818	-423.5061	932
6...	6473	2016-03-16 22:57:19.000	105203205E9606C1	51.68629	985.71...	0	44.319...	-0.8...	0.83...	0.77...	-0.02490234	0.02294922	-1.020508	-51.11044	-421.1762	932
6...	6474	2016-03-16 22:57:41.000	105005205E9607B3	58.17282	983.79...	0	42.984...	-0.9...	1.86...	-0.5...	0.9975586	0.1459961	-0.03320313	148.5801	-386.7301	877
6...	6475	2016-03-16 22:57:42.000	104991205E9607C4	57.80603	984.26...	0	45.334...	-0.9...	-0.0...	1.27...	-0.9638672	0.1582031	0.2070313	7.478206	-86.30861	330
6...	6476	2016-03-16 22:58:01.000	105203205E9606C1	51.64767	985.56...	0	44.319...	-0.8...	0.67...	0.61...	-0.02099609	0.02197266	-1.00293	-51.46537	-424.0438	932
6...	6477	2016-03-16 22:58:23.000	105005205E9607B3	58.13422	983.64...	0	42.984...	-0.7...	1.77...	-0.3...	0.9970703	0.1469727	-0.03173828	147.8726	-386.3739	876
6...	6478	2016-03-16 22:58:24.000	104991205E9607C4	57.76742	984.3	0	45.349...	-0.7...	0.45...	1.34...	-0.9487305	0.1474609	0.1987305	7.300153	-85.40956	330
6...	6479	2016-03-16 22:59:05.000	105005205E9607B3	58.13422	983.72...	0	42.984...	-0.8...	1.73...	-0.1...	0.9985352	0.1547852	-0.0532266	148.757	-386.1959	876
6...	6480	2016-03-16 22:59:25.000	105203205E9606C1	51.55115	985.61...	0	44.3273	-0.9...	0.66...	0.90...	-0.02392578	0.02050781	-1.014648	-50.57804	-420.9969	932
6...	6481	2016-03-16 22:59:48.000	105005205E9607B3	58.03769	983.70...	0	42.9769	-0.6...	2.08...	-0.4...	0.9985352	0.1552734	-0.03710938	148.4032	-387.2642	876

**Figure 7. ACTS data are archived in an SQL database.**

### Outdoor Testing

The outdoor testing included the ACTS tags, a waterproofed base station transmitter/receiver/computer, and an empty 30B container. The base station was actually another DecaWave EVK1000 radio that communicated with the tags and moved transmitted data to the

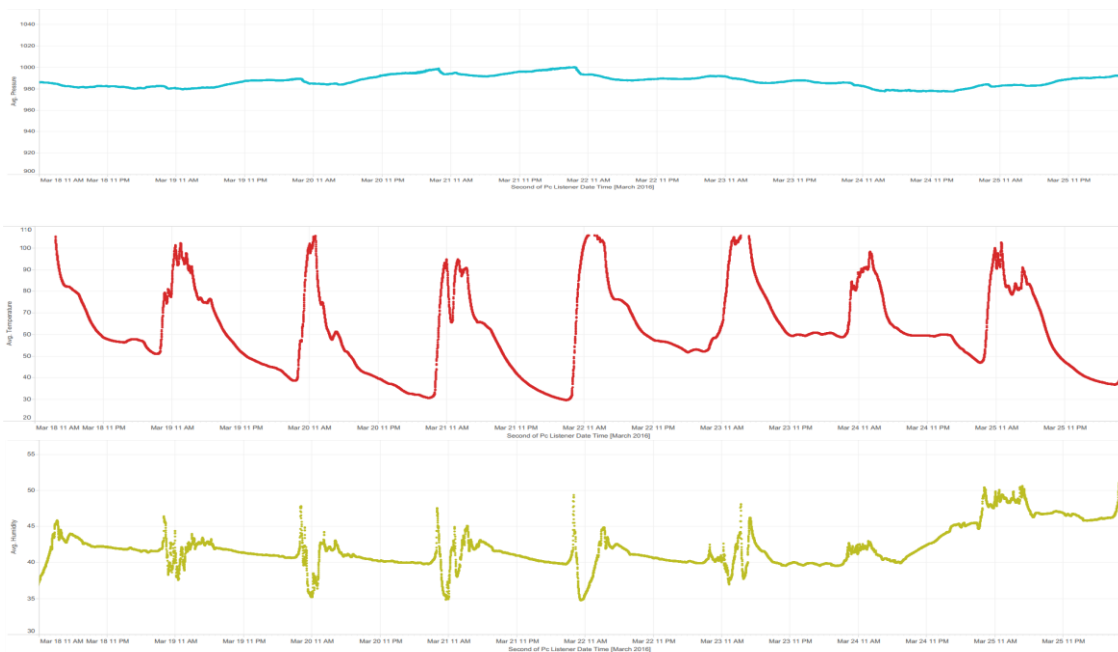

**Figure 8. Outdoor 30B container device placement**

computer. Initially, five of the new boxes were placed on the outdoor 30B container in various locations as shown in Figure 8. The base station was deployed within line of sight of the tags and was connected via USB to a laptop inside a trailer with electrical power. The laptop was then connected to the internet using an industrial router connected to a cellular bridge. For this deployment, collected data were stored in ASCII files which were transmitted back to office computers using a file syncing service to enable data analysis to occur at the same time as collection activities. Data analysis was performed using Tableau 9.3. The outdoor deployment occurred after initial testing was performed indoors to confirm operation of the boxes but prior to extensive evaluation of the individual sensors to expose the system to both cold and wet conditions in the early spring of 2016. Initially, the new ABS-printed boxes were placed in plastic bags because there were known issues with ABS-printed enclosures and waterproofing. It was thought that painting the boxes would help reduce the likelihood of leaking, so as boxes were painted, they were removed from the

plastic bags. After painting and removing all the boxes from plastic bags, leaking occurred in one box that was the most exposed to the elements during a heavy rain. The box design was then modified to improve the waterproofing of the enclosure.

The boxes were deployed outdoors from March 16 until April 24, 2016. Figure 9 shows pressure, temperature, and relative humidity data that were collected from one tag from March 18 to 25, 2016. Relative humidity values were closely monitored during the deployment as a potential indicator of a leak in the enclosure of the box. Data from the outdoor deployment were used to find minor software bugs in data collection from the sensors, and led to improvements in embedded software design that greatly enhanced system reliability and stability.



**Figure 9. Outdoor barometric pressure, temperature, and relative humidity collection, March 18 to 25, 2016.**

### Indoor Testing

Indoor testing took place in a laboratory inside a large industrial building. The temperature, humidity, and pressure remained relatively stable during testing. Despite this, further environmental-chamber



**Figure 10. Indoor testing setup.**



testing will be performed in the near future. Testing included magnetometer orientation response, accelerometer response, temperature/humidity/pressure, and light, as described below.

### 1. Magnetometer Testing

The magnetometer was tested for 360-degree rotational response using a nonmetallic cart. The cart placement was manually controlled and rotated based on an internal laboratory reference. Two different locations within the laboratory were chosen for all the tests, and both boxed and unboxed devices were tested as shown in Figure 11. The primary result was that shielding by the battery was noticed in the boxed measurements (Figure 11, left column), as can be seen in the difference above 200 degrees displacement. The top and middle row of curves should be identical except for offset due to the magnets if there is no interference do to other metallic objects. Above 200 degrees, it can be seen that the left-column curves appear to be compressed. This was due to the metal-cased batteries in the boxed set of tests in the left column. This will be corrected in a future packaging redesign.

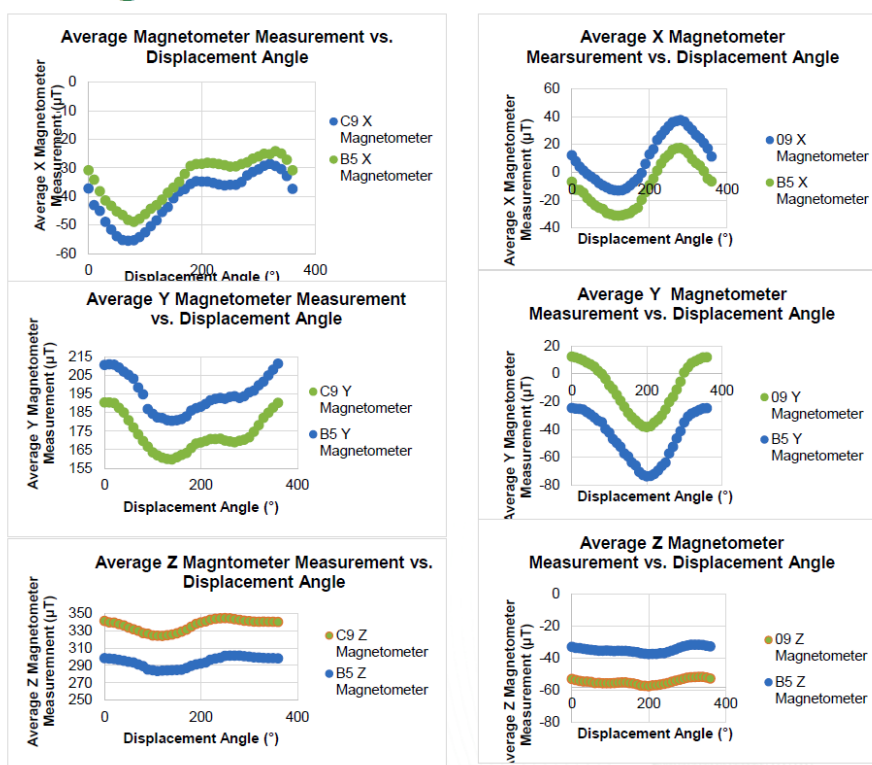

**Figure 11. Typical magnetometer results.**

### 2. Environmental Sensor Testing

We measured all sensors during the testing so that we would not only have a record of temperature and the other environmental conditions, but also so that we would be able to monitor any obvious

crosstalk issues between the various sensors. As can be seen in Figure 12, there was less than 1 °F, 2 mbar, and 0.1% humidity variation in the environment during a typical run.

### Conclusions

The current status of part of the testing ACTS system has been presented. The system is presently working as designed, but testing is ongoing. Testing planned for the near future includes environmental chamber testing and power usage monitoring. We are also undergoing a redesign of the box to accommodate thin flat-pack batteries and a reduction of the peripheral board size.

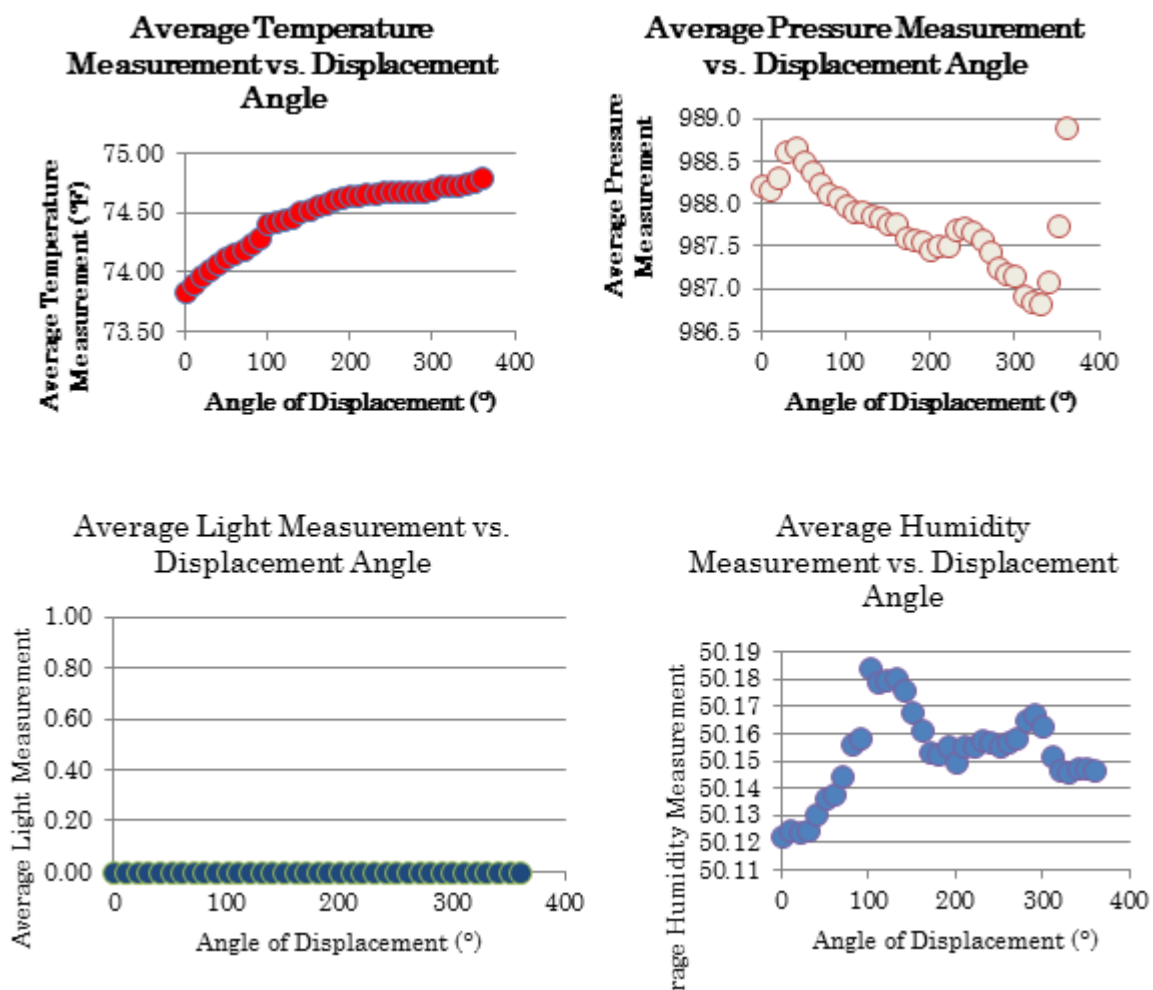

**Figure 12. Example environmental sensor measurement.**

### References

[1] C. L. Britton et al., “Enhanced Containment and Surveillance System: Active Container Tracking System (ACTS),” Presented at the 37<sup>th</sup> Annual ESARDA Meeting, May 18-21, 2015, Manchester, England.

[2] J. Anderson, H. Lee, P. De Lurgio, C. M. Kearney, B. Craig, I. H. Soos, H. Tsai, Y. Liu, and J. Shuler, "Tracking and Monitoring with Dosimeter-Enabled ARG-US RFID System," WM2012 Conference, February 26–March 1, 2012, Phoenix, Arizona, USA.