

Paper No. 2042

Evaluation of Structural Integrity of Metal Cask due to impact of Tornado Missile with Strain-Based Criteria

Yuko Sakamoto

Central Research Institute of Electric
Power Industry

Toshiko Udagawa

WDB Co., Ltd.

Koji Shirai

Central Research Institute of Electric
Power Industry

Kosuke Namba

Central Research Institute of Electric
Power Industry

Abstract

In Japan, Nuclear Power Plant facilities must be protected against the tornado missile impact prescribed by regulatory requirement amended in 2014. Accordingly, the evaluation of the structural integrity of dual purpose metal cask impacted by the tornado missile may be required. In the case of evaluation of dynamic phenomena of the steel structures subjected to large impact energy, strain-based criteria may be desirable. In appendices of ASME code Section III, these criteria for container of transportation and storage of radioactive material and waste are prescribed. In this study, we evaluated the structural integrity of dual purpose metal cask by these criteria, when the top of the cask was impacted by the tornado missile and compared vertical drop test condition onto a pin from 1m height.

Introduction

In Japan, Nuclear Power Plant facilities must be protected against the tornado missile impact prescribed by regulatory requirement amended by Nuclear Regulatory Authority in 2014[1]. Accordingly, the evaluation of the structural integrity of dual purpose metal cask impacted by the tornado missile may be required. This cask should maintain its structural integrity and sealing performance not to release any radioactive materials at any accidental condition prescribed by the IAEA regulation.

Generally, the structural design of metal cask has been accomplished by stress based criteria. However, when the metal cask is subjected to energy limited events, such as aircraft and tornado missile impacts, strain-based criteria may be reasonable because these criteria allow plastic deformation. In these criteria, strain at tensile strength or strain at fracture measured in uniaxial tensile test is proposed as a strain limit. The strain limit of metal materials should be applied the effect on the ductility depending on stress state given by the triaxiality factor (TF). Therefore, we evaluated the structural integrity by these strain-based criteria based on numerical analysis using LS-DYNA ver.971, when the top of cask was impacted by the representative tornado missile, and compared the result of vertical drop test condition from the top of the cask onto a mild steel pin with 15cm diameter from 1m height.

Strain-based Criteria

TF is defined as the ratio of a summation of principal stresses to effective stress in eq. (1). For example, TF =1 and 2 represent the uniaxial tension and biaxial tension states, respectively. When the compression state is ascendant, TF gives negative value.

$$TF = \frac{\sigma_1 + \sigma_2 + \sigma_3}{\sigma_e} \quad (1)$$

In the nonmandatory appendices of ASME code of Section III, two strain-based criteria are introduced for energy-limited events of container for transportation and storage of radioactive material and waste [2]. The one is for average equivalent plastic strain through section at each evaluated location, given by eq. (2). Another one is for the maximum equivalent plastic strain at any containment location, given by eq. (3). However, the use of these criteria are allowed to only stainless steel.

$$[TF \cdot \varepsilon_{eq}^p]_{avg} \leq 0.67 \cdot \varepsilon_{uniform} \quad (2)$$

$$[TF \cdot \varepsilon_{eq}^p]_{max} \leq [\varepsilon_{uniform} + 0.25(\varepsilon_{fracture} - \varepsilon_{uniform})] \quad (3)$$

Where, ε_{eq}^p : Equivalent plastic strain, $\varepsilon_{uniform}$: True strain at tensile strength in a uniaxial tensile test, $\varepsilon_{fracture}$: True strain at fracture in a uniaxial tensile test, TF : Associated TF value with ε_{eq}^p . Equation (2) and (3) are for location away from a gross or local structural discontinuity.

When TF is lower than 1.0, TF shall be 1.0 in eq. (2) and (3).

$\varepsilon_{uniform}$ and $\varepsilon_{fracture}$ should be determined by the results of material tensile test.

On the other hand, in JSME code for PWR steel containment vessel during severe accident [3], limiting triaxial strain is introduced for local equivalent plastic strain. In this criterion, as the strain limit, m_2 given by eq. (4) is applied, which represents $\varepsilon_{uniform}$. Applicability of this criterion for dynamic phenomena was confirmed in our previous study by free drop test results using steel plates and heavy weight imitated the shape of the tornado missile [5].

$$m_2 = 0.60 \left(1 - \frac{\sigma_{ys}}{\sigma_{uts}}\right) \quad (\text{Ferritic steel}), \quad m_2 = 0.75 \left(1 - \frac{\sigma_{ys}}{\sigma_{uts}}\right) \quad (\text{Stainless steel}) \quad (4)$$

Where, σ_{ys} , σ_{uts} : Yield stress and tensile strength in JSME material code [4]

In this study, we carried out the evaluation of the structural integrity of the metal cask with eq. (2) and eq. (3) using m_2 as $\varepsilon_{uniform}$ instead of obtaining it from material tensile test, and the second term of eq. (3) was ignored conservatively because $\varepsilon_{fracture}$ is not given generalized formula.

Impact analysis conditions

Impact scenarios due to tornado missile and drop test II

Figure 1 shows the impact scenarios, which include the tornado missile impact and drop test II. For these scenarios, the reference dual purpose cask for BWR spent fuels with double lids was used. In the case of the tornado missile impact scenario, the tornado missile hits the top of cask in the vertical orientation. In the case of drop test II scenario (1m drop test on to mild steel pin) from the top of the cask, the gap between the content and cask lid was set to 15 mm as an initial condition.

Metal cask

Figure 2 and Table 1 show the overview of the cask analysis model and specification of the model, respectively. The half-model was used for both evaluations considering the symmetry configuration of the cask. The model consists of a body, primary lid, secondary lid, tightening bolts of the lids and content. The body and primary lid include resin as neutron shielding material. The metal materials are carbon steel and stainless steel. The content consisting of spent fuels and a basket was simplified as a cylinder. Trunnions were not considered in this

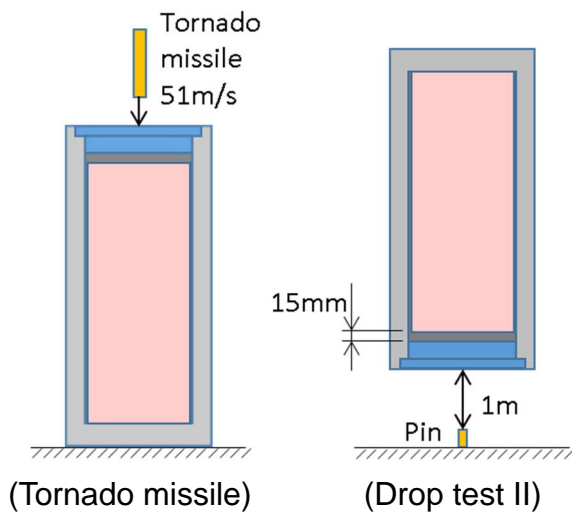

Figure 1 Impact scenarios

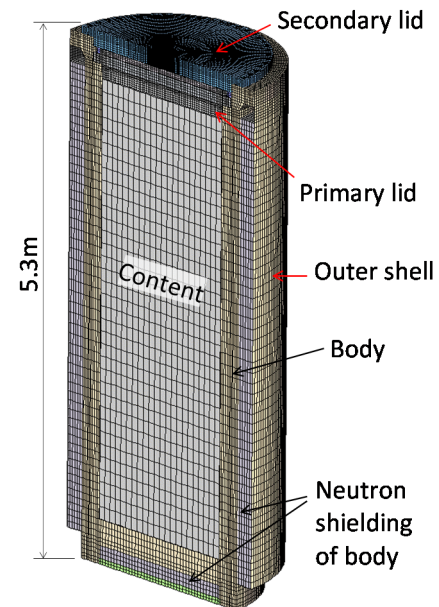
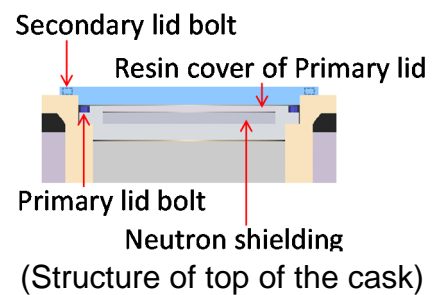

Figure 2 Analysis model of metal cask

Table 1 Detail of reference cask

Part	Body	Outer shell	Primary lid	Secondary lid	Content	Assembled
Size (mm)	Inner dia.	Outer dia.	Outer dia.	Outer dia.	Outer dia.	Height
	1552	2408	1776	2088		
	Thickness	Thickness	Thickness	Thickness		
	223	15	294	163	1543	5300
Weight (ton)	72.4		3.8	3.7	30.8	110.7

model. Table 2 shows the reaction forces of metal gaskets and initial bolt axial tensions of the tightening bolts. The reaction forces of the gaskets for sealing system of the cask were given at the contact region between the flange of body and two lids. The outer shell of the body was made of shell element, and other parts were made of solid elements. Friction coefficient of contact surfaces between the flange, primary lid and secondary lid were 0.6 [6], and the coefficient of other contact surfaces was 0.52 [7]. In the case of the impact analysis with the tornado missile, the bottom of the cask was fixed completely. Then, 2% stiffness damping was applied to the model.

Tornado missile and pin

Table 3 and figure 3 show the overview of the analysis models and details of the tornado missile and pin, respectively. The model of the tornado missile was applied 16mm thick and 1.1m length as a rigid missile because the original tornado missile was considered as a deformable missile not to give large damage to the cask lid [5].

The tornado missile was made of shell element and the pin was made of solid element. The materials of both were carbon steel. Regarding pin, this material choice was conservative to this evaluation since the material prescribed by IAEA safety standards is mild steel. Moreover, the bottom of the pin was fixed completely.

Material model

Table 4 and 5 show the material properties of the cask, tornado missile and pin. Regarding the material models of the outer shell and content, elastic models were applied. The model of the neutron shielding was applied an elastic-plastic model with a multi-linear stress-strain curve [6]. The models except for them, elastic-plastic models with tri-linear stress-strain

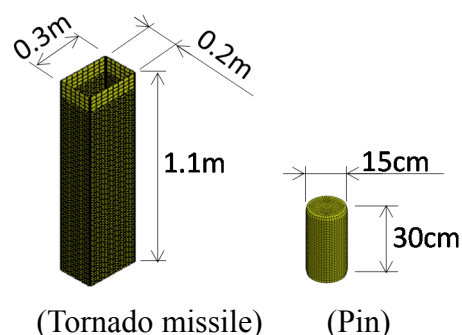

Figure 3 Analysis model of tornado missile and pin

Table 2 Reaction force of gaskets and initial bolt axial force of lids

	Reaction force of gasket	Diameter of gasket	Initial bolt axial force
Primary lid	858 kN/mm	1598 mm	353 kN
Secondary lid	858 kN/mm	1860 mm	181 kN

Table 3 Detail of tornado missiles and pin

	Dimensions	Mass	Max impact velocity
Tornado missile* (original) [1]	0.3m width, 0.2m depth, 4.2m length	135kg	51m/s (Horizontal)
Tornado missile (for analysis)	0.3m width, 0.2m depth, 1.1m length, 16mm thick	135kg	51m/s
Pin	15cm diameter, 30cm length	42kg	4.4m/s (by cask)

* The thickness is 4.22mm if its density is 7.86ton/m³.

curves were applied. The true strains at tensile strengths of cask parts except for resin were m_2 , and the true strains at tensile strength of the tornado missile and pin were decreased 90% from m_2 to analyze conservatively. Temperature dependency was not considered in the material properties.

Strain rate effect was considered to the material properties of the body, primary and secondary lids, resin cover, tightening lid bolts, tornado missile and pin using dynamic increase factor (DIF) introduced in NEI report [7]. The range of the strain rates were set from 10^{-4} to 10^2 . DIFs at 10^{-4} /s were 1.0 and DIFs at 10^2 /s were shown in table 6.

Result of impact analysis

Impact analysis with tornado missile

The equivalent plastic strain ϵ_{eq}^p contours of the secondary lid and flange of body, time histories of velocity of the tornado missile, and the opening displacements of the primary and secondary lids are shown in Figure 4. The tornado missile rebounded at 0.9msec. At the impacted area by the tornado missile, the maximum ϵ_{eq}^p of secondary lid was 0.17%. Although the maximum ϵ_{eq}^p occurred along the inner edge of flange for secondary lid was 0.016%, no plastic strains occurred at the areas where the gaskets were installed including the primary lid.

Table 4 Material property (at room temperature) [4, 8-12]

Part	Material	Yield stress (MPa)	Tensile stress (MPa)	Young modulus (MPa)	Density (ton/m ³)	Poisson's ratio (-)	Maximum true uniform strain (-) ^{*1}
Body/ Secondary lid	JSME-N4 GLF1	207	414	202000	7.85	0.3	0.300
Primary lid	SUSF304	205	480	195000	7.93	0.3	0.429
Resin cover of primary lid	SUS304	205	520	195000	7.93	0.3	0.454
Neutron shielding	Resin	54.43	163.30	7350	1.60	0.268	0.1078
Primary / secondary lid bolts	SNB23-3	890	1000	191000	7.85	0.3	0.066
Outer shell	SGV480	-	-	202000	7.85	0.3	-
Content	SGV480	-	-	94000	3.67	0.3	-
Tornado missile / Pin	SN490B	325	490	205000	7.86	0.3	0.184 ^{*2}

*1 True strain limit given by m_2 .

*2 90% of m_2 .

Table 5 True stress-strain relation of shielding material [6]

Eq. stress (MPa)	54.43	85.0	100.0	111.0	117.75	122.50	126.0	163.30	163.30
Eq. pl. strain (-)	0	0.0014	0.0039	0.0079	0.0120	0.0168	0.0229	0.1078	0.7778

Table 6 DIF for material strength at 10^2 /s [7]

Magnified value of Carbon steel at 10^2 /s	Yield stress	1.29
	Tensile strength	1.10
Magnified value of Stainless steel at 10^2 /s	Yield stress	1.18
	Tensile strength	1.0

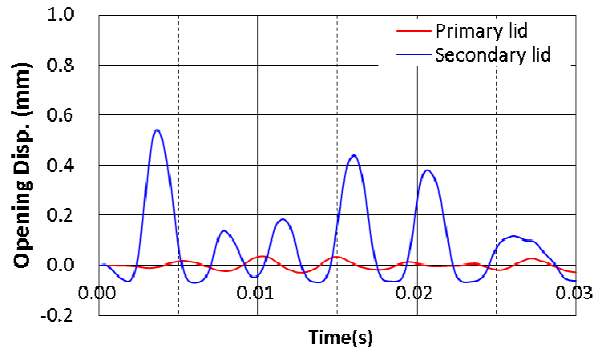
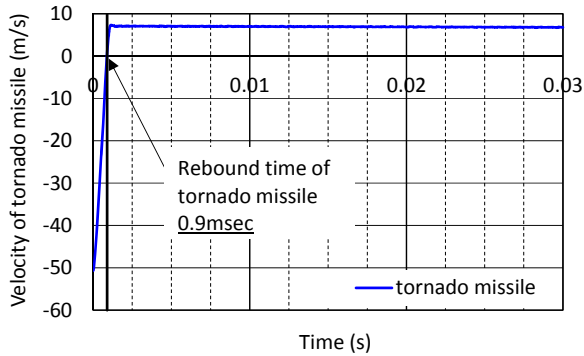
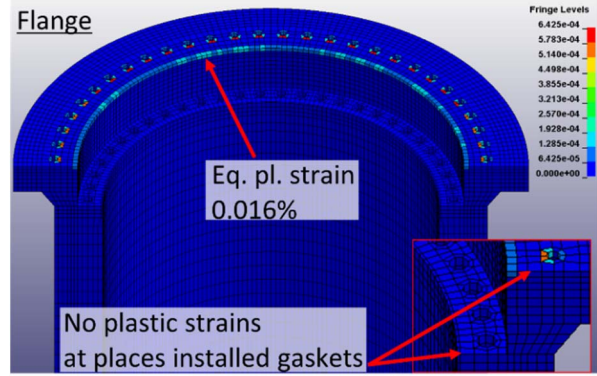
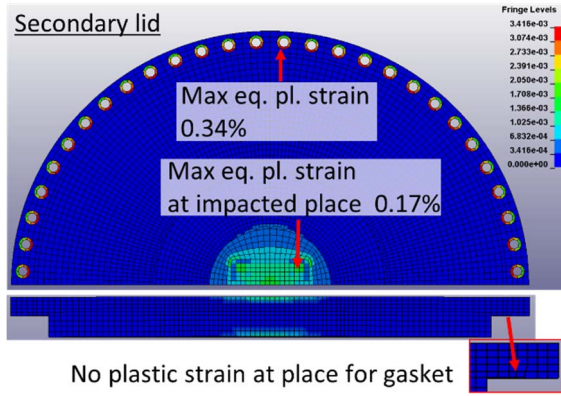

Figure 4 ϵ_{eq}^p Contours and time histories of impact analysis by tornado missile

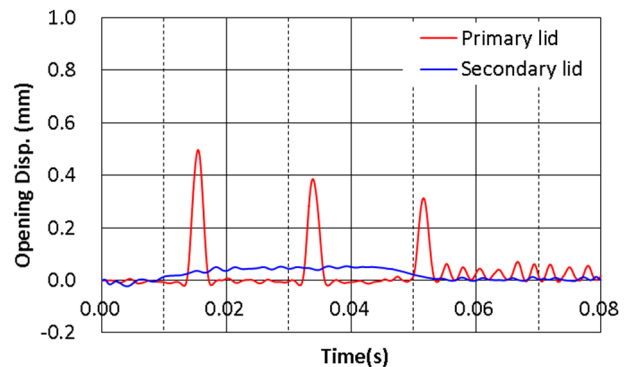
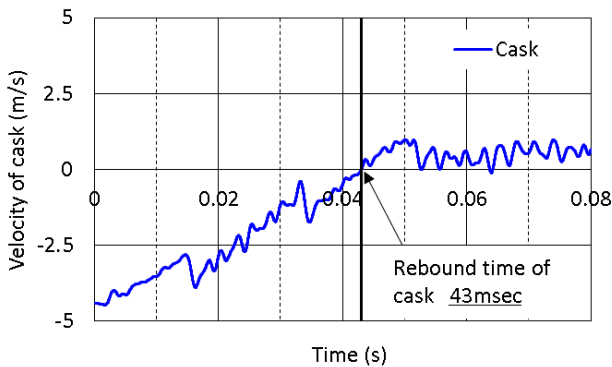
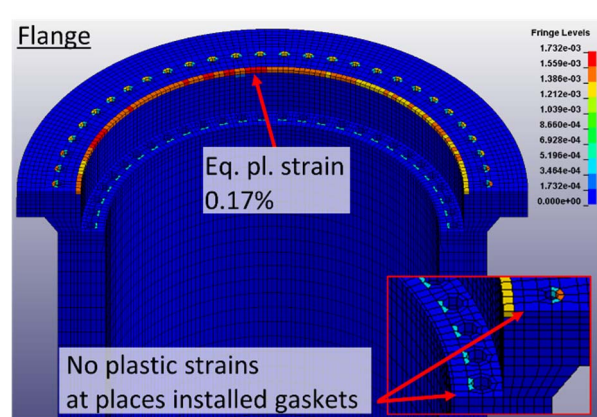
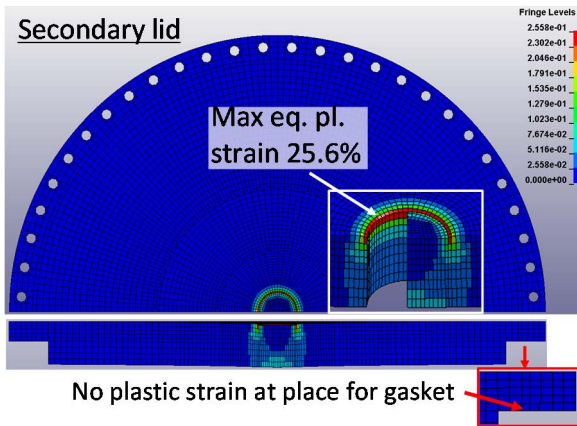

Figure 5 ϵ_{eq}^p Contours and time histories of impact analysis onto pin

Regarding the opening displacement, the response of the secondary lid, the maximum instantaneous displacement 0.6mm occurred by free vibration of the secondary lid after rebounding of the tornado missile although the response of the primary lid was negligible. In addition, the equivalent stresses of the tightening bolts for two lids were under yield stress and the sliding displacements of two lids were also negligible. Therefore, it was considered that the confinement ability of sealing system of the cask was maintained after the impact.

Impact analysis onto pin

Figure 5 shows the ϵ_{eq}^p contours and time histories of the impact analysis onto the pin. The maximum ϵ_{eq}^p of the secondary lid was 25.6% at the edge of the footprint by the pin. Regarding the flange, no ϵ_{eq}^p occurred at the places for two gaskets same as the impact analysis with the tornado missile. The pin was plastically deforming under the secondary lid until the cask rebounded at 43msec. Although the maximum opening displacement of the secondary lid was 0.1mm, this displacement returned to 0mm after the cask rebounded. On the other hand, the several peaks in the opening displacement of the primary lid occurred by the impact of the content to the lid at 15, 33 and 52msec due to the 15mm gap between the content and primary lid. In spite of these peaks, the residual opening displacements were negligible. In addition, the sliding displacements of two lids were also negligible and no plastic strains occurred at the areas where the gaskets were installed including the primary lid. Therefore, it was considered that the confinement ability of the cask was maintained after the impact.

Figure 6 shows the time histories of TF, products of ϵ_{eq}^p and TF of the secondary lid and strain-based criteria by for $[TF \cdot \epsilon_{eq}^p]_{avg}$ and $[TF \cdot \epsilon_{eq}^p]_{max}$ of each element through the section at the maximum ϵ_{eq}^p . These products and strain-based criteria were normalized by $\epsilon_{uniform}$ of the secondary lid. According to the time histories of TF, compressive stress state was ascendant through the section and almost all of TFs were under 1.0 during this impact phenomena. Therefore in these strain-based criteria, these TFs were compensated to 1.0.

From the time histories of normalized products and strain-based criteria, the fracture of

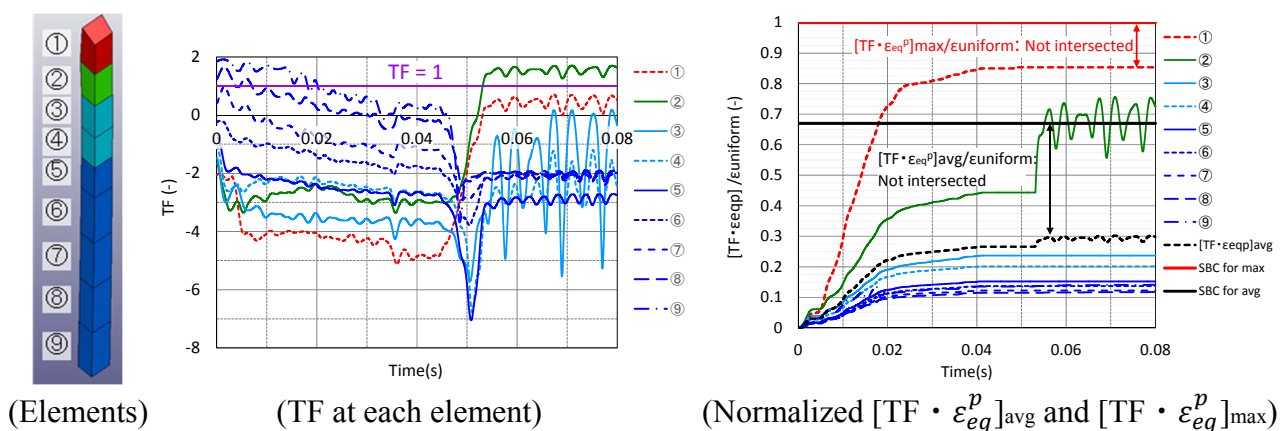

Figure 6 Time histories of TF and products of equivalent plastic strain and TF normalized by $\epsilon_{uniform}$

the secondary lid did not occur because $[TF \cdot \varepsilon_{eq}^p]_{\max}$ given by element 1 and $[TF \cdot \varepsilon_{eq}^p]_{\text{avg}}$ of all elements through the section were not intersected with each strain-based criterion given by red and black solid lines. In addition, the maximum residual deformation of the secondary lid was under 10% of the initial thickness. Therefore this evaluation of drop test II condition using these strain-based criteria was reasonable compared to the classical evaluation comparing the shear force to penetrate the secondary lid by the pin with the force to generate plastic deformation of the pin.

Conclusions

We confirmed that the loss of the structural integrity of cask was negligible subjected to the tornado missile impact prescribed by NRA, and drop test II condition included this tornado missile impact scenario. In addition, regarding drop test II condition, we confirmed that the damage of secondary lid evaluated with these strain-based criteria was less than the damage evaluated by the classical method comparing the shear force to penetrate the thickness of the secondary lid by the pin to the force required to generate plastic deformation of the pin.

References

- [1] 2014, “The guide of the evaluations of tornado effect on commercial nuclear power reactors and its facilities,” NRA, No.1409172.
- [2] 2013, “ASME Boiler & Pressure Vessel Code”, ASME, Appendices of Section III, Division 3
- [3] 2015, “Codes for Nuclear Power Generation Facilities - Structural Integrity Evaluation Guideline under Severe Accident Condition - (PWR Steel Containment Vessel),” JSME, JSME S NX4-2015.
- [4] 2012, “Codes for Nuclear Power Generation Facilities – Rules on Materials for Nuclear Facilities –”, JSME, JSME S NJ1-2012.
- [5] 2016, “PROPOSAL FOR EVALUATION WITH STRAIN-BASED CRITERION OF IMPACT PHENOMENA BETWEEN STEEL STRUCTURE AND TORNADO MISSILE”, No.60171, ICONE24
- [6] 2010, “EVALUATION OF SEALING PERFORMANCE OF METAL CASK SUBJECTED TO HORIZONTAL IMPACT LOAD OF AIRCRAFT ENGINE”, JAPAN SOCIETY OF CIVIL ENGINEERS (JSCE), p.177-193, Journal of JSCE, Division A, Vol. 66.
- [7] 2015, “Methodology for Performing Aircraft Impact Assessments for New Plant Designs,” NEI, NEI 07-13, Revision 8P.
- [8] 2007, “JSME Mechanical Engineers' Handbook Fundamentals”, JSME
- [9] 2009, “JSME Data Book: Heat Transfer 5th Edition”, JSME
- [10] 2010, “Ferrous Materials & Metallurgy I”, JAPANESE STANDARDS ASSOCIATION (JAS), JIS Handbook
- [11] 2010, “Ferrous Materials & Metallurgy II”, JAS, JIS Handbook
- [12] 2005, “Design Standard for Steel Structures - Based on Allowable Design Concept -”, Architectural Institute of Japan