

**Paper No. 2008      Development of a simulation tool for the  
thermal evaluation of transport and storage casks**

**Christian Dinkel**

University of Bayreuth, Germany

**Michael Frisch**

University of Bayreuth, Germany

**Daniel Billenstein**

University of Bayreuth,  
Germany

**Bernd Roith**

Swiss Federal Nuclear  
Safety Inspectorate ENSI,  
Switzerland

**Frank Rieg**

University of Bayreuth,  
Germany

**Abstract**

Basically, the safe dissipation of heat is among others an important protection objective of transport and storage casks (T/S-casks). High temperature within the cask can lead to significant decrease in strength of the used materials and to thermal stresses due to different thermal expansion.

Gas-filled gaps between various components play a major role for the thermal behavior of casks because they act as thermal barriers due to the lower heat conductivity of gaseous fluids in comparison to metallic materials. However, additional heat transmission mechanisms, such as natural convection and radiation can also occur in a gaseous medium [1]. For the evaluation of the thermal cask behavior within a Finite-Element-Analysis (FEA), every important thermal transfer mechanism has to be considered in each gap for a precise simulation. This leads to both an expanded modelling and a prolonged computing time.

Within the scope of a research project the Chair of Engineering Design and CAD of the University of Bayreuth in cooperation with the Swiss Federal Nuclear Safety Inspectorate ENSI developed a simulation tool for the fast thermal evaluation of T/S-casks which combines analytical methods and FEA. The innovation thereby is that gas-filled gaps are not meshed. Their influence on thermal processes is rather considered by using analytical equations. By means of the Lagrange multiplier method [2], additional mathematical functions between nodes can be applied, even though these nodes are not connected by a finite element. These functions act like boundary conditions and are referred to as thermal gap conditions (TGC). By the use of TGC, significant advantages like modelling efforts and reduced computing time can be achieved.

**Introduction**

Gas-filled gaps within T/S-casks can play a major role for heat dissipation. Due to a significantly lower heat conductivity of gaseous fluids in comparison to metals, this transfer mechanism is on the one side not able to transport a huge amount of heat. On the other side, further heat transport mechanisms occur in fluids, such as convection and radiation. According to guidelines of ENSI [3],

the temperature within T/S-casks has to be limited. Because of the small dimensions of these gas filled gaps in relation to the rest of the cask, finite element simulations (FE-simulation, FEA) or computational fluid dynamics simulations (CFD) are very time-consuming because of a high number of finite elements and nodes.

In a research project at the University of Bayreuth (Germany) and ENSI (Switzerland) an innovative simulation tool has been developed. This novel tool evaluates the thermal behavior of T/S-casks and their thermomechanical effects. Based on the Finite-Element software Z88 - developed at the Chair of Engineering Design and CAD of the University of Bayreuth [4] - analytical equations have been integrated in this numerical software in order to accelerate the simulation.

### Lagrange multiplier method for thermal simulation

In regard to thermal FE-simulations the following matrix equation has to be solved, whereby  $K$  represents the thermal conductivity matrix,  $T$  the temperature vector and  $Q$  the heat flow vector [5]:

$$KT = Q \tag{1}$$

In case of contact between two or more parts, for example, several methods are known from the literature. Therefore additional information has to be integrated in the equation system. One of the most common methods is called Lagrange multiplier method [6]. In this method, additional equations are inserted as Figure 1 shows for two single elements in contact. So called Lagrange multipliers connect the separated conductivity matrices of the unlinked elements.

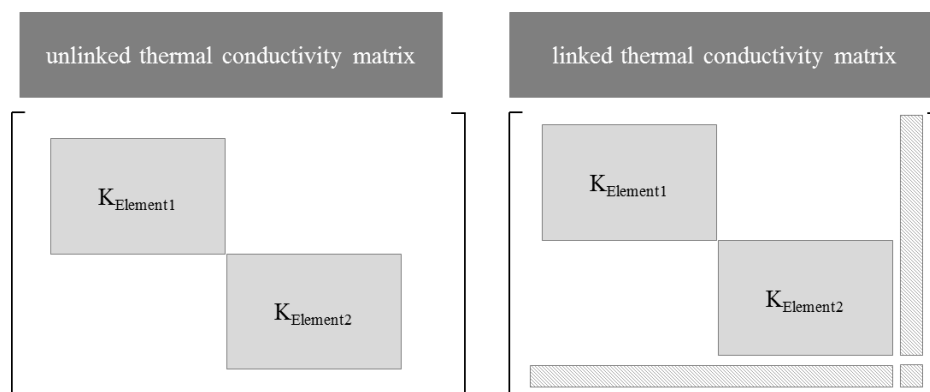

**Figure 1 Schematic representation of an unlinked (left) and linked (right) thermal conductivity matrix for two single finite elements**

This method works for contact problems, but in general all kinds of known information can be transmitted by including them into the equation system [2]. For instance Figure 2 shows two quadratic isoparametric plane stress elements for thermal application, separated by a gap. Due to the Lagrange multiplier method, these elements can be connected, although there is no physical contact between them.

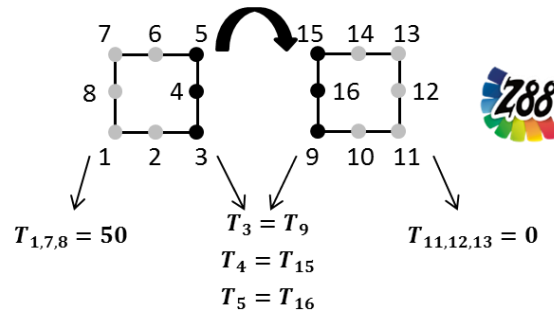
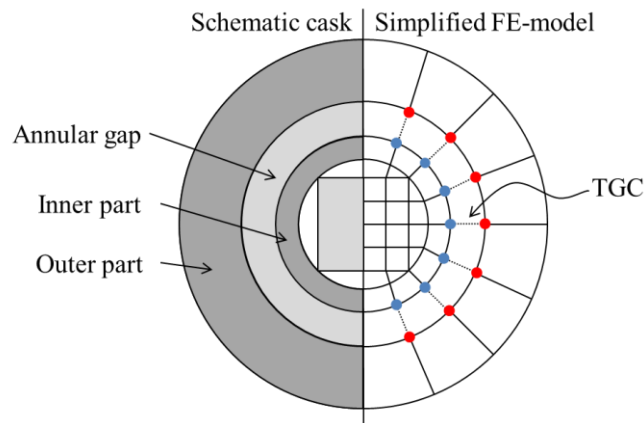

**Figure 2 Simulation of two plane elements connected by Lagrange method**

Thereby, a transmission function is defined, as Figure 2 shows:  $T_3 = T_9$ ,  $T_4 = T_{15}$ ,  $T_5 = T_{16}$ . In doing so, the simulation computes a solution temperature for the unknown temperatures at the nodes 3, 4, 5, 9, 15 and 16 of  $T_{3,4,5} = T_{9,15,16} = 25$  by use of the boundary conditions  $T_{1,7,8} = 50$  at the nodes 1, 7 and 8 and  $T_{11,12,13} = 0$  at the nodes 11, 12 and 13. The results are as expected.

### Simulation tool

In case of T/S-casks, an annular gas-filled gap exists between inner and outer part of the cask. This gap acts like a barrier regarding the heat dissipation. Within the mentioned research project, a so called thermal gap condition (TGC) has been developed. This special kind of boundary condition is used for representing the thermal effects within the annular gap without actually meshing this region of the Finite-Element model. Figure 3 provides a schematic illustration of the considered gap.



**Figure 3 Schematic illustration of inner and outer cask part; left: schematic cask model; right: simplified FE-model**

The TGC builds a connection between every blue node of the inner part and the red nodes of the outer part of the cask. Now, a TGC has to be defined, which matches the thermal effects in the Helium-filled annular gap.

### Thermal gap condition

In total three heat transfer mechanisms can occur in gaseous mediums: conduction, convection and

radiation [1]. Within the research project, only conduction and convection have been considered. Due to the fact that a fast and rough assessment of the thermal behavior was the aim of the research project, radiation has been excluded because of a small influence and prolonged computation duration. For conduction, the analytical formula of heat conduction is used, as equation 2 demonstrates:

$$T_{OP} = T_{IP} - \frac{\dot{Q}}{2\pi l \lambda_{He}} \ln \frac{r_{OP}}{r_{IP}} \quad (2)$$

Here,  $T_{OP}$  marks the temperature value of the outer part's nodes, whereas  $T_{IP}$  contains the values of the nodes at the inner gap wall. Furthermore,  $\lambda_{He}$  represents the thermal conductivity of the fluid (here: helium),  $l$  for the gap width,  $\dot{Q}$  for the heat flow from inner to outer part and  $r_{OP}$  and  $r_{IP}$  for the radius of inner and outer part. This equation can be included as TGC in the equation system between all nodes which are located at the surfaces of inner and outer part of the cask.

In case that convection is also important for the heat transfer within the gap, the TGC of formula 2 is adapted. According to [1], convection can be considered in analytical calculations as equation 3 shows:

$$\lambda_{CC} = Nu \cdot \lambda_{He} \quad (3)$$

This means that the actual initial value of the thermal conductivity  $\lambda_{He}$  is modified by the Nusselt number  $Nu$ . This leads to a new value of the thermal conductivity  $\lambda_{CC}$  for the gas within the gap (index cc: conduction and convection). By doing this a new thermal conductivity can be determined. Hence this new value is inserted in formula 2 for a modified TGC.

### Program sequence

Figure 4 embeds the TGC in the context of the developed software called Z88ENSI. The whole tool works with ASCII-files and additionally offers a graphical user interface (GUI). The programming language is C.

At first, a geometry import is necessary, which contains a Finite-Element mesh of the particular T/S-cask. Furthermore, different gap widths of an existing Finite-Element model can be simulated. This can be realized by modifying the node position of those nodes which are next to the annular gap. Users can conveniently alter different gap sizes without changing the actual model. Therefore the influence of the gap size can be evaluated.

This is followed by several thermodynamic data, like, among others, thermal conductivity and viscosity of the gas in the gap. These values are required for the estimated calculation of the Nusselt number which is needed for the correct choice of the TGC.

As usual in FEA, boundary conditions have to be defined. This could be temperature or heat flow definitions. After that, the Finite-Element mesh is scanned to detect all nodes which are located at the inner or outer side of the gap, to establish the TGC on these nodes later on. Before the TGC can be

integrated within the equation system, the potential convection flow within the gap is calculated. To do this, additional functions based on analytical correlations are needed [7]. These functions have to be solved using a numerical search of zero. In this project the bisection method is applicable.

On the basis of the cask's ambient temperature, which is defined by the user, the software calculates the estimated temperature and the fluid velocity in the annular gap and can draw a conclusion about the value of the Nusselt number. If the Nusselt number is larger than 1, convection has to be integrated in the TGC, according to formulas (2) and (3). If the value is smaller or equal to 1, conductivity is the only heat transfer mechanism and formula (2) describes the TGC.

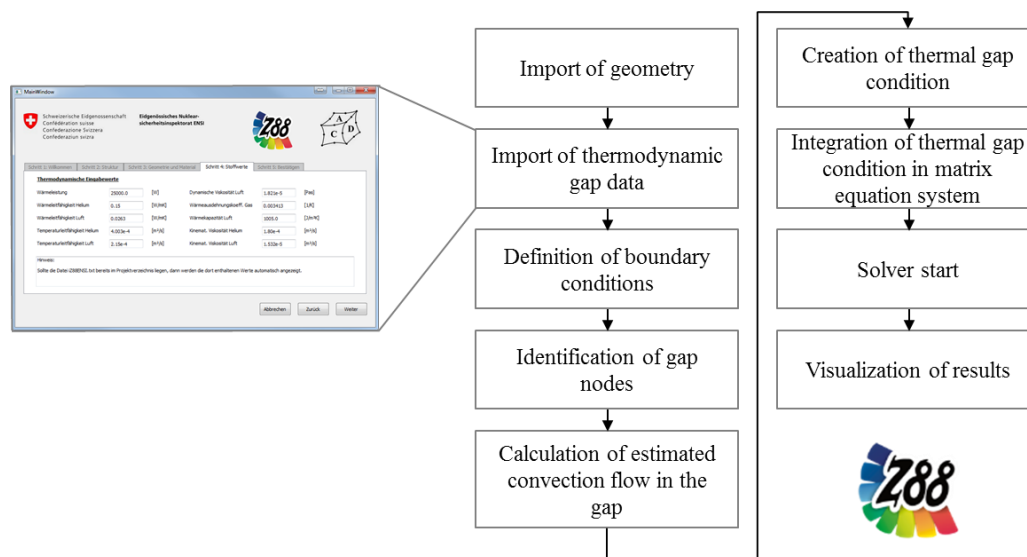

**Figure 4 Program sequence of the software tool Z88ENSI**

Subsequently, the Finite-Element equation system is solved using a direct sparse matrix solver. The results can be plotted in the GUI of Z88 [4]. So, the temperature distribution and the heat flow through the cask can be interpreted.

If, in addition to the thermal boundary conditions, mechanical boundary conditions such as fixed supports or forces are defined as well, the solver automatically executes a thermomechanical simulation. Based on the temperature solutions for each node, the thermal expansion of the cask is simulated in order to receive the gap geometry in hot condition.

### Example of application

To demonstrate the software tool, an exemplary T/S-cask is simulated using Z88ENSI. The cask design, the boundary conditions and loads are fictive and do not represent an existing cask. At first, Figure 5 demonstrates the meshed model. Thereby, no lids are applied, because it is assumed that the majority of the heat amount leaves the cask radially. The cask model is much simplified and consists of three components (see Figure 5, bottom left, numbered parts), whereby every component acts as homogeneous material:

1. Basket
2. Rails
3. Outer cask

This fictive model has the following dimensions:

- Height: 3.50 m
- Outer diameter: 2.80 m
- Gap width: 0.01 m

No fuel assemblies are modeled at all. The boundary conditions can also be seen from Figure 5, bottom left. A heat flow of 20 kW is defined on the walls of the basket (see boundary condition 2 in Figure 5, bottom left). Furthermore, the surface temperature at the exterior wall (boundary conditions I) of the cask is set to 60 °C. Top and bottom of the cask have isothermal walls.

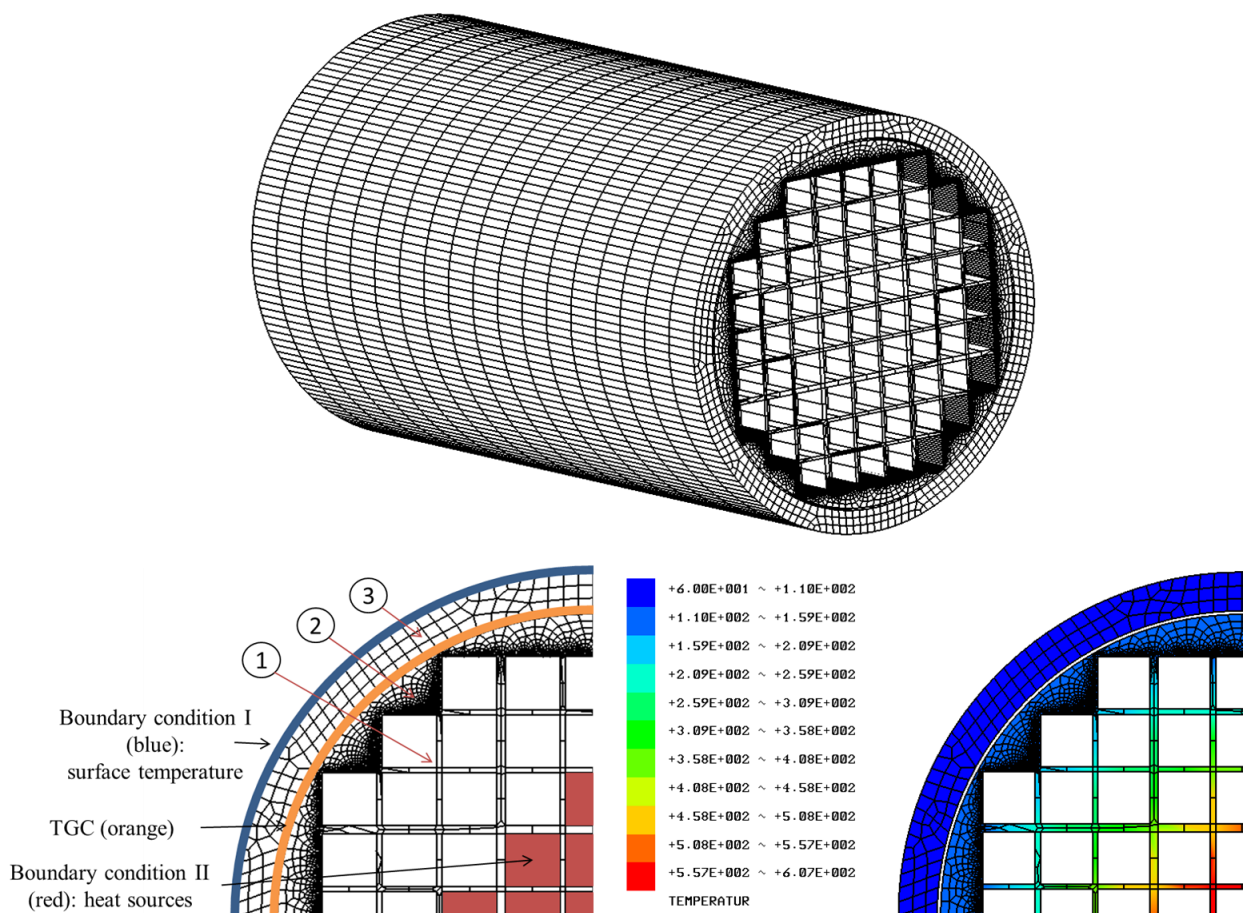

**Figure 5 Top: Meshed full model of an exemplary, fictive T/S-cask; Bottom left: meshed model with boundary conditions; Bottom right: calculated temperature distribution of cask cross section in °C**

Although Figure 5 bottom shows a quarter-section, a full model was simulated (see Figure 5, top). Because of the rotationally symmetric boundary conditions and results, only a quarter-section is pictured in Figure 5, bottom. As element type, linear hexahedron elements are used. The mesh

consists of about 135.000 elements and 155.000 nodes. About 5.500 additional equations occur due to the TGC-installation.

The result of the simulation can be seen in Figure 5, bottom right. The center of the cask is the hottest region. The maximum temperature is 607 °C which is, in comparison to existing casks, extremely high. It should be noted, that this example is not realistic. The fact that the whole heat flow is specified at the center of the cask leads to very high temperatures and an accumulation of heat in the basket.

At the exterior wall, the defined boundary condition sets the temperature value to 60 °C. In the exterior area the temperature decreases, as expected.

In total, the solver needs about one minute to compute the thermal simulation, whereas the computation duration for the search of the gap-related nodes is already included. By using the Lagrange multiplier method, additional equations have to be solved. This prolongs the computation time marginally.

## **Conclusions**

Thermal Finite-Element models of T/S-casks which consider all existing gas filled gaps, would entail tremendous modelling and computational efforts. Because of this, the University of Bayreuth in cooperation with ENSI developed a software tool that is able to provide an approximated thermal and thermomechanical evaluation of T/S-casks. Based on the completely independent Finite-Element system Z88, the software Z88ENSI significantly shortens the calculation duration. Using particularly developed thermal gap condition, the thermal effects of an important annular gap can be considered without meshing it. With this tool, fast and approximate evaluations of T/S-casks are possible. The maximum temperature in the cask due to different loading conditions and material parameters can be simulated.

Of course, the presented method is only possible, if the thermal processes are known. In case of unknown transmission functions, common Finite-Element-Analyses have to be made. For complex geometries it must be investigated if analytical equations are able to approximate the real heat transfer mechanisms.

## **Acknowledgments**

This research project was kindly supported by ENSI, Swiss Federal Nuclear Safety Inspectorate, Brugg, Switzerland.

## **References**

- [1] Verein Deutscher Ingenieure: VDI-Wärmeatlas. 11th edition. Springer Vieweg. Berlin, Heidelberg. 2013.
- [2] Bathe, K.-J.: Finite-Elemente-Methoden. Springer-Verlag. Berlin, Heidelberg, New York, Tokyo. 1986.

- [3] ENSI: Richtlinie G05: Transport- und Lagerbehälter für die Zwischenlagerung. 2008.
- [4] Rieg, F., et al.: Z88Aurora® User Manual. Version V3. University of Bayreuth. Bayreuth, Germany. 2015.
- [5] Rieg, F., Hackenschmidt, R., Alber-Laukant, B.: Finite Elemente Analyse für Ingenieure, Grundlagen und praktische Anwendung mit Z88Aurora. 5th edition. Carl Hanser Verlag. München. 2014.
- [6] Wriggers, P.: Computational Contact Mechanics. 2nd edition. Springer Verlag. Berlin, Heidelberg, New York. 2006.
- [7] Müller, U., Ehrhard, P.: Freie Konvektion und Wärmeübertragung. 1st edition. C. F. Müller Verlag. Heidelberg. 1999.