

**DROP-WEIGHT RING COMPRESSION TEST FOR EVALUATING THE
MECHANICAL BEHAVIOR OF FUEL RODS UNDER IMPACT CONDITIONS**

Elena Torres Alvarez Jesus Ruiz-Hervias Miguel A. Martin Rengel
Materials Science Department. Technical University of Madrid. 28040 Madrid, Spain.
jr@mater.upm.es

ABSTRACT

Several static and dynamic tests have been proposed to assess impact behaviour of spent fuel cladding. For example, the three-point bending test was used to simulate the loading conditions during a 9m-lateral regulatory drop test. The ring compression test has been chosen by several laboratories as a tool to assess cladding mechanical properties as well, though not under dynamic loading conditions. The main advantage of this test is its simplicity. However, strain rates representative of impact loading cannot be attained with conventional testing machines. To this end, a drop-weight tower was used to perform ring compression tests. This test intended to simulate the pinch forces generated in the contact between the cladding and the spacer grid under hypothetical transport accident conditions.

The aim of this work is to examine the possibilities that the drop-weight ring compression test can offer for the evaluation of cladding response under impact conditions. For that purpose, a comparison between results obtained in both dynamic (i.e. drop-weight tests) and quasi-static (i.e. conventional testing machines) ring compression tests was made.

INTRODUCTION

Understanding the response of cladding to impact has become an increasing concern for transport regulators due to its influence on criticality safety.

Several static and dynamic tests had been tried to assess impact behaviour of cladding in the framework of different research projects. The three-point bending test and its variations [1, 2] have been used for simulating the loading during a 9m-lateral regulatory drop. During the Fuel Integrity Project carried out by BNFL and ACL [2, 3], besides the three-point bending tests, lateral compression and loading tests were performed. Horizontal and axial impact tests using full-length irradiated rods were carried out as part of the experimental program.

The ring compression test has been chosen by several laboratories as a tool to assess cladding mechanical properties [4-6]. The main advantage of this test is its simplicity.

However, the use of a conventional testing machine does not allow the application of high deformation rates. The introduction of slight modifications in a commercial tower allowed us to perform ring compression tests at higher displacement rates, which intended to be more representative of hypothetical transport accident conditions.

The aim of this work is to examine the possibilities that the ring compression test can offer for the evaluation of cladding response under impact conditions. For that purpose, a comparison between conventional (quasi-static) and high-strain rate ring compression tests (RCT) was made.

All tests performed in the framework of this work were conducted on unirradiated ZIRLO[®] cladding both as-received and pre-hydrided with 500 ppm hydrogen at room temperature and 300°C.

EXPERIMENTAL SET-UP

Test specimens

The material used for this work was unirradiated ZIRLO[™] cladding. Test specimens were obtained by cutting the cladding into 10-mm-long rings.

In the tests, cladding specimens in “as-received” conditions and pre-hydrided with 500 ppm hydrogen were used. Hydriding was induced via cathodic charging in KOH aqueous solutions.

Drop weight impact tester

The impact experiments were performed in a drop-tower test machine (Dynatup 8250, Instron, Massachusetts, USA) (Figure 1). The machine provides a motorized latch block that suspends a crosshead. Upon computer command, the crosshead was released from the latch block into free fall guided by two twin columns. The velocity of the crosshead was measured by using an infrared sensor fixed to the drop tower, which detected the velocity at the impact position.

In order to perform ring compression tests at high deformation rates, this commercial drop-weight impact tester was modified. A new striker was designed. A flat-bottom cylinder was made in a F522 tempered steel (dimensions are shown in Figure 1). Besides, for tests at 300°, a tailor-made oven was coupled between the guide columns, above the T-grooved baseplate.

For the tests performed in the context of this work, the gravity-driven mode was used and an impact velocity of 3 m/s was applied.

Ring compression tests

An INSTRON 8803 testing machine, equipped with a 5 kN load cell, was used to perform quasi-static ring compression tests at room temperature and 300°C. For the tests at 300°C, an INSTRON 3119 furnace was used. Tests were performed with a displacement rate of 0.5 mm min⁻¹ ($8 \cdot 10^{-6}$ m s⁻¹).

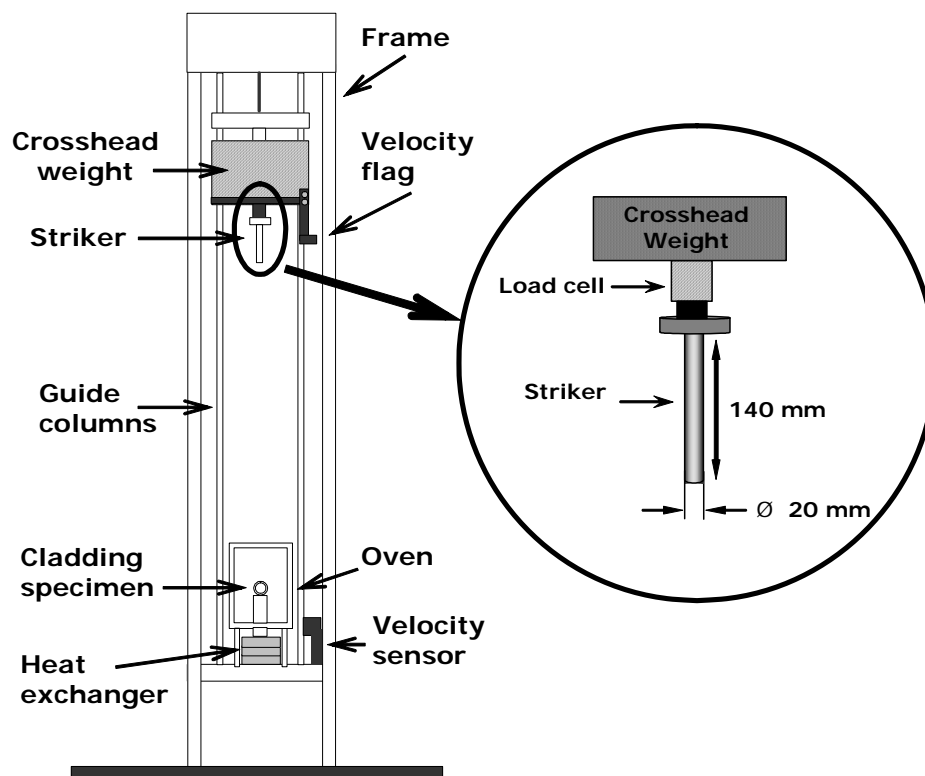

Figure 1. Scheme of the drop weight tester and the modifications performed for the RCT.

Scanning electron microscopy and optical observations

Cross-sections of tested specimens were embedded in an epoxy resin and prepared for metallographic observation. SiC papers ranging from #240 to #1200 grit sizes were used during the grinding. Afterwards, samples were polished sequentially with a 9, 6, 3 and 1 micron diamond paste. Prior to etching, samples were polished with a 0.030 micron SiO₂ suspension. The etching solution consisted in an acid mixture HF/H₂O₂/HNO₃ (10:10:80). Optical observation was performed with a Carl Zeiss Axiovert 100A inverted light-transmitted microscope.

The resulting fracture surfaces at equatorial positions of the tested specimens were subjected to qualitative fractographic examination in a Zeiss Auriga field emission scanning microscope.

RESULTS

In order to examine the possibilities that the drop-weight ring compression test can offer for the assessment of cladding response under impact conditions, a comparison between results obtained in both dynamic and quasi-static RCT's was made.

Tests were performed on unirradiated and prehydrided ZIRLO cladding both as-received and with 500 ppm hydrogen. Tests were conducted at room temperature and

300°C, using two displacement rates (0.5 mm/min and 3 m/s for the quasi-static and dynamic tests, respectively).

Load– displacement curves

Load-displacement curves show that the effect of hydrogen concentration is similar in both, the dynamic and quasi-static RCTs. For this reason, only the influence of temperature and displacement rate will be assessed in this section.

Load-displacement curves recorded at room temperature show that maximum load is reached at smaller displacement values when dynamic loading is applied. This behaviour is observed for both, pre-hydrided and as-received cladding (Figure 2). At 300°C, however, cladding response against impact improves despite hydriding, possibly due to the dissolution of pre-existing hydrides (Figure 3).

Consequently, the results show that cladding stiffness and strength increase at high strain rates. It is generally expected that during an accident, the higher load application rate would lead to better cladding strength [3]. For this reason, quasi-static RCT's were carried out at slow deformation rates in order to analyse the cladding behaviour in the worst case scenario.

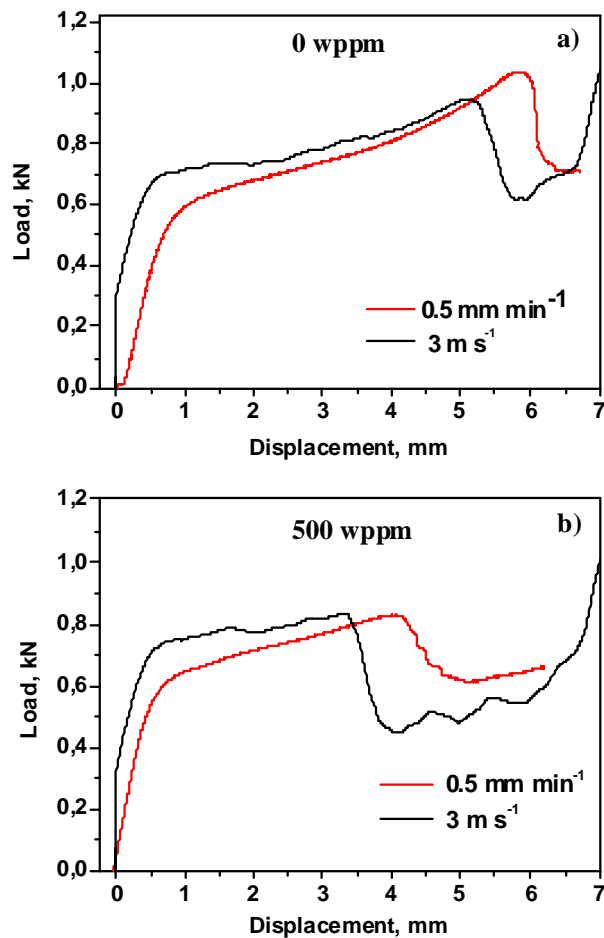

Figure 2. Load-displacement curves of RCT conducted at room temperature and two different displacement rates (0.5 mm min⁻¹ and 3 m s⁻¹): a) Zirlo® in as-received state; b) pre-hydrided with 500 wppm hydrogen.

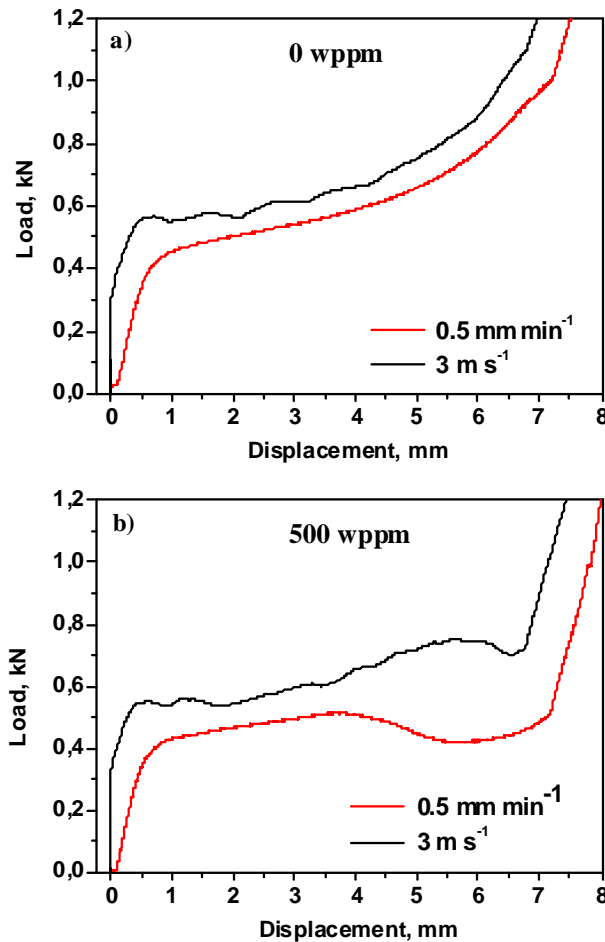

Figure 3. Load-displacement curves of RCT conducted at 300°C and two different displacement rates (0.5 mm min^{-1} and 3 m s^{-1}): a) Zirlo® in as-received state; b) pre-hydrided with 500 wppm hydrogen.

Metallographic characterization

Optical examinations of tested specimens showed the failure of the cladding at the ring equatorial location ($\theta = 0^\circ$ and $\theta = 180^\circ$). Optical micrographs exhibit large cracks in equatorial positions in both, hydrided and as-received cladding samples tested under, both, quasi-static and dynamic loadings.

a) Quasi-static tests

In quasi-static tests, it has been observed that failure is associated to a microscopically ductile mechanism, which leaves dimples on the fracture surface.

At temperatures around 300°C, the zirconium matrix ductility increases and dissolution of pre-existing hydrides may occur. Due to the slow deformation rate and the stress gradient along the cladding wall, hydrides may re-precipitate at the outer diameter of the cladding. These re-precipitation patterns are not observed at higher displacement rates.

b) Dynamic tests – Drop-weight tower

In the case of dynamic tests, temperature seems to play a relevant role on the failure mechanism. Damage is less severe at 300°C than at room temperature.

Optical micrographs of 500-wppm hydrided specimens tested at room temperature show that equatorial positions were severely damaged and an appreciable loss of material was observed. At 300°C, however, crack depth was about two thirds of cladding thickness (Figure 4).

Similar behaviour was observed in the case of Zirlo[®] cladding in as-received conditions. At room temperature, cracks in equatorial positions propagate through the cladding, whereas at 300°C, crack depth was about half of the cladding thickness (Figure 5).

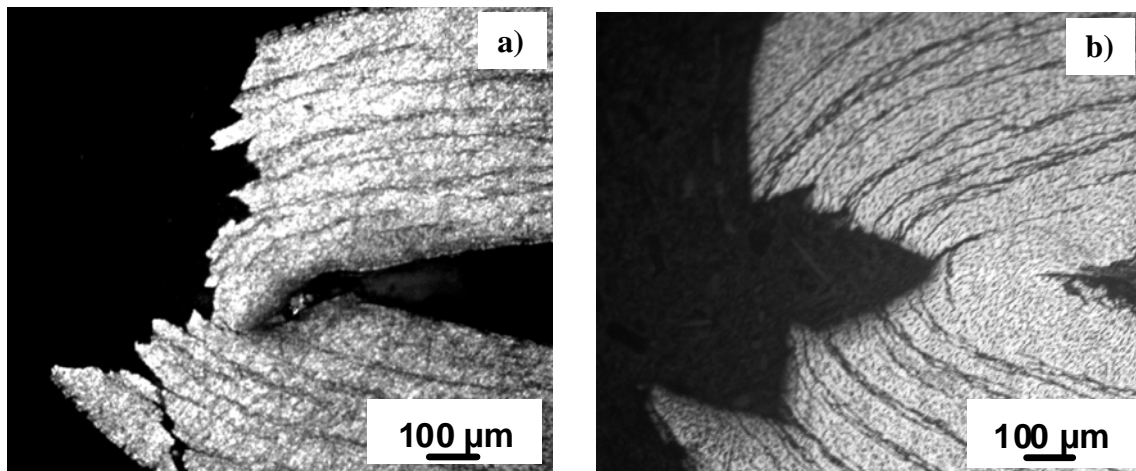

Figure 4. Optical micrographs of the equatorial positions of Zirlo[®] specimens hydrided with 500 wppm and tested in drop weight tower: (left column) room temperature; (right column) 300°C.

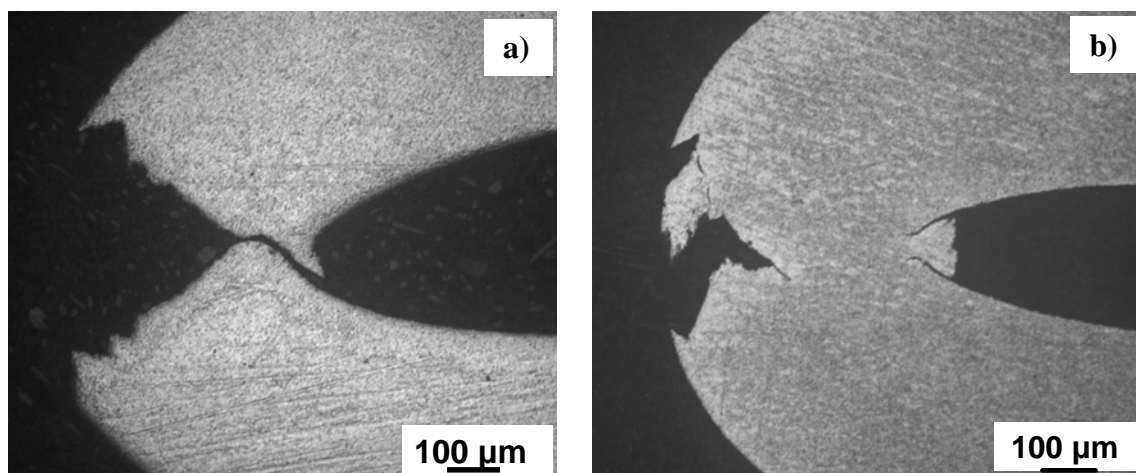

Figure 5. Optical micrographs of the equatorial positions of Zirlo[®] specimens in as-received conditions tested in the drop weight tower: a) room temperature; b) 300°C.

In any case failure is observed at displacements larger than 3 mm in all cases, so the macroscopic behaviour is ductile in all cases.

Fractographic characterization of the fracture surface

In quasi-static loading conditions, a typical ductile fracture surface was observed, with the presence of microvoids oriented in the direction of crack growth. Test temperature did not seem to influence the fracture mechanism. Similar results were obtained for both pre-hydrated and as-received samples.

Under dynamic loading conditions, microscopically brittle areas can be observed in most of the fracture surface of hydrided cladding at room temperature (Figure 6). Regions of ductile fracture are also found but they are limited to the zirconium matrix. Precipitates found inside dimples may favour the nucleation and coalescence of microvoids (Figure 7).

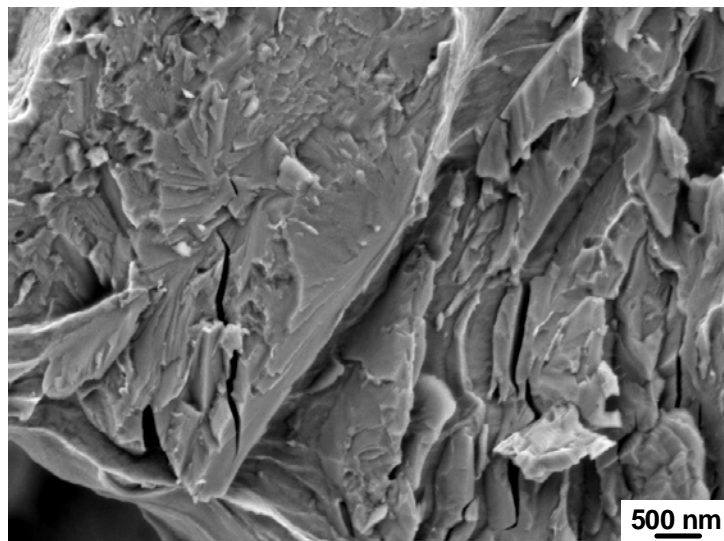

Figure 6. Brittle area found in the fracture surface of a 500-wppm pre-hydrated specimen tested at room temperature under dynamic loading.

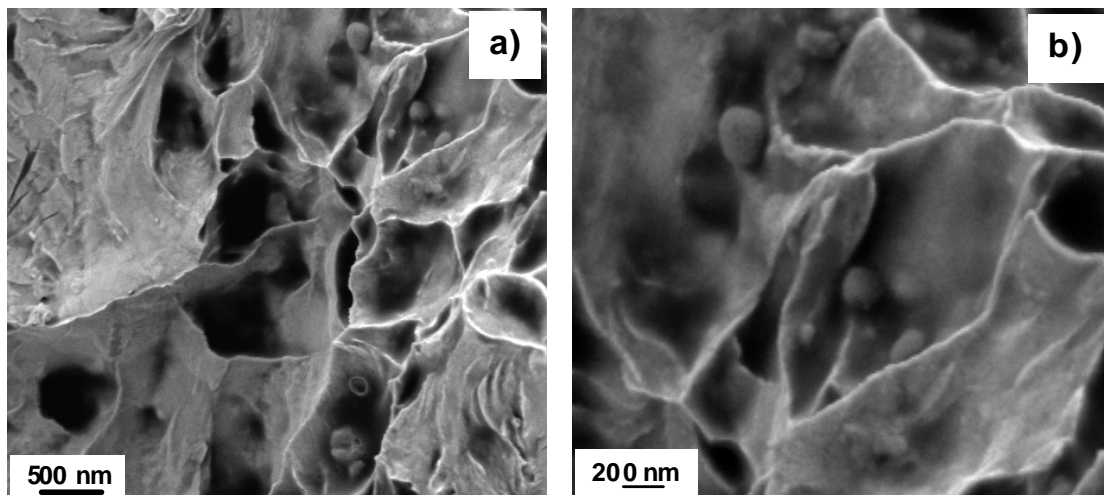

Figure 7. a) Microvoid coalescence in a microscopically-ductile fracture of the zirconium matrix; b) higher magnification of intermetallic precipitates found in the dimples.

At 300 °C, fracture is microscopically ductile, as can be seen in Figure 8. From these results and the load-displacement curves, it can be seen that temperature has a beneficial effect on cladding ductility, particularly in pre-hydrided samples.

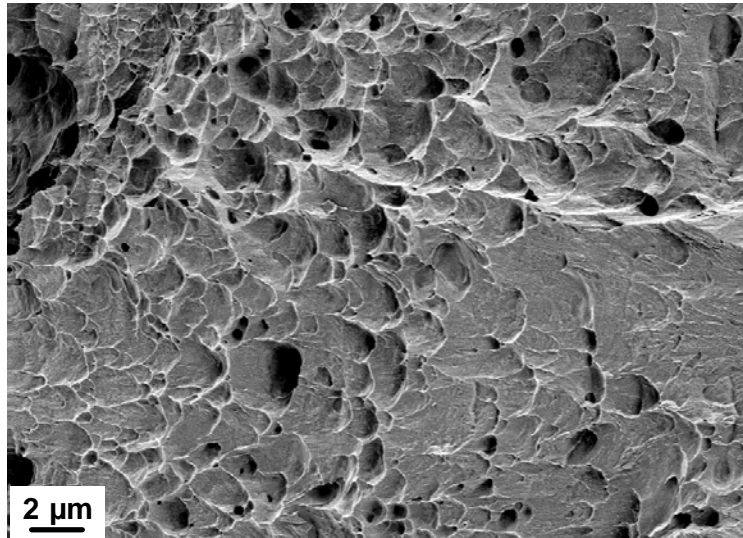

Figure 8. Dimples oriented along the crack propagation direction on the fracture surface of a 500-wppm pre-hydrided specimen (drop-weight RCT at 300°C)

CONCLUSIONS

Cladding stiffness and strength increased at increasing displacement rates. This fact supports the generally accepted assumption that during an accident the higher load application rate would lead to better cladding strength.

The effect of temperature and hydrogen concentration on load-displacement curves is similar in both the dynamic and quasi-static ring compression tests.

Increasing temperature has a beneficial effect under dynamic loading. Microscopically brittle areas can be observed in most of the fracture surface of pre-hydrided cladding at room temperature. However, increasing temperature favours a certain recovery of ductility, this being clearly noticeable at 300°C. In any case failure is observed at displacements larger than 3 mm in all tests, so the macroscopic behaviour is ductile in all cases.

ACKNOWLEDGEMENTS

The authors wish to acknowledge the financial support received from Ministerio de Ciencia e Innovación (project BIA2011-26486) and ENUSA Industrias Avanzadas, ENRESA and Consejo de Seguridad Nuclear (CSN) for collaboration and support in the project. They would also like to thank the helpful comments and suggestions made by Profs. M. Iordachescu, A. Valiente and L. Caballero.

REFERENCES

1. Papaioannou, D., et al., *Hot cell crash tests and accident loading studies on nuclear fuel rods*, in *IAEA Consultancy Meeting on the Small Cask for Spent Fuel Sample Transportation between Hot Laboratories*. 2010: Vienna, Austria.
2. Purcell, P.C. and M. Dallongeville, *Testing of LWR fuel rods to support criticality safety analysis of transport accident conditions*. RAMTRANS, 2004. **15**(3-4): p. 265-272.
3. Dallongeville, M., J. Werle, and G. McCreesh, *Fuel Integrity Project: Analysis of results of tests on light water reactor fuel rods*. RAMTRANS, 2005. **16**(2): p. 125-133.
4. Busser, V., et al., *Mechanical response of oxidized Zircaloy-4 cladding material submitted to a ring compression test*. Journal of Nuclear Materials, 2009. **384**: p. 87-95.
5. Daum, R., S. Majumdar, and M. Billone, *Mechanical Behaviour of High Burn-up Zircaloy-4 Fuel Cladding. Experimental and Analyses of Ring Compression Loading*, in *15th International Symposium on Zirconium in Nuclear Industry 2007*: Sunriver, Oregon.
6. Nagase, F., T. Chuto, and T. Fuketa, *Ring Compression Ductility of High Burn-up Fuel Cladding after Exposure to Simulated LOCA conditions*. Journal of Nuclear Science and Technology, 2011. **48**(11): p. 1369 -1376.