

**DROP TESTING OF THE DN30 PROTECTIVE STRUCTURAL PACKAGING  
FOR THE TRANSPORT OF URANIUM-HEXAFLUORIDE**

**Wolfgang Bergmann**

Nuclear Cargo + Service GmbH  
(DAHER-NCS)

**Thomas Breuer**

Nuclear Cargo + Service GmbH  
(DAHER-NCS)

**ABSTRACT**

The design of the DN30 protective structural packaging (PSP) developed by DAHER-NCS for the transport of natural, enriched and reprocessed Uranium-Hexafluoride up to an enrichment of 5 wt.% in 30B cylinders was presented at PATRAM 2010 [1]. The presentation given at this time included a description of the design features, information about the mechanical analysis by Finite-Element calculations and an overview about the drop test program.

The presentation at hand describes the performance and results of these drop tests which were performed in 2012.

The drop tests were carried out in 2012 at the drop test facility of BAM, Germany according to a drop test program which was agreed between NCS-DAHER and the French and German competent authorities.

The drop test program consisted of five drop test sequences in different orientations which might lead to maximum damage as requested by the Regulations. Each sequence consisted of a 1.2 m free drop simulating normal conditions of transport, a 9 m free drop and a 1 m drop test onto the bar. The tests were performed with five full scale prototypes of the DN30 PSP and 30B cylinders. To simulate the UF<sub>6</sub> content the cylinders were filled with steel balls.

As general drop orientations the corner drop valve side, the corner drop plug side, the side drop slap down, the side drop onto the closing system and the flat drop onto the valve side were chosen.

The results of these tests are described in the following.

Only after the drop tests were completed it became apparent that the supply of the phenolic foam used in the prototypes could not be secured for the serial production. Hence it was decided to change the used phenolic foam to Polyisocyanurate (PIC) foam which requires the repetition of some of the already carried out drop test sequences.

In the mean time static and dynamic drop tests with PIC foam samples were performed. The results of which are described in a different presentation at this PATRAM [2].

The outstanding additional drop tests with new prototypes equipped with the new foam will start in September 2013.

## DESCRIPTION OF THE DN30 OVERPACK DESIGN

The DN30 overpack is shown in Figure 1.

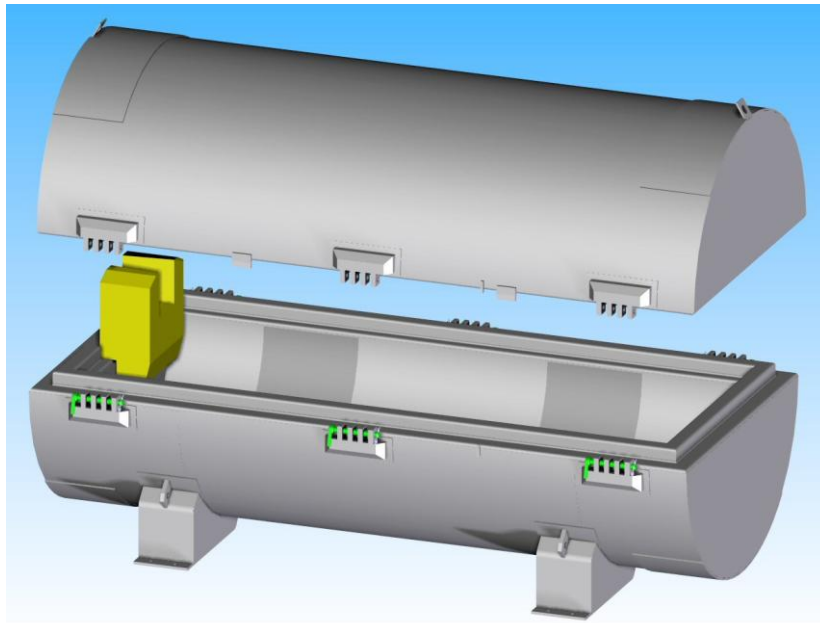

**Figure 1: Overpack Design DN30**

The overpack is a right circular horizontal loading container which consists of a top and bottom half which are connected with six sliding axis systems. A gasket is fitted on the step-joint part between both halves to prevent water inlet. Sponge rubber strips are pasted on the inner shells of the bottom and top half to prevent direct contact of the inner shell with the 30B cylinder.

The halves consist in principle of an inner and outer stainless steel shell and energy-absorbing and insulating closed-cell phenolic foam of different densities filling the space in between. Lifting and tie-down interfaces permit the safe handling and stowing of the overpack.

As a protection of the valve against mechanical impacts under normal and accident conditions of transport the lower half is equipped with an integrated valve protector.

The handling of the complete package is performed by using slings or chains attached to the lifting rings located on the DN30 feet or by fork lift. Handling of the top half is done over lifting rings fixed at the ends of the top half.

Tie-down is performed over holes in the feet of the overpack, the location of which are compatible to other existing overpack designs. The design allows the transport of 4 overpacks on a flatrack.

For loading or unloading of the DN30 overpack it is not necessary to remove the overpack from the flatrack.

The design fulfills the requirements of ISO 7195 and US standard ANSI N14.1.

The main characteristics of the DN30 overpack design are summarized in Table 1.

**Masses approx.:**

<b>Total overpack empty</b>	<b>1110 kg</b>
<b>Max. Gross weight package</b>	<b>4100 kg</b>

**Dimensions:**

<b>Length</b>	<b>2435 mm</b>
<b>Width</b>	<b>1198 mm</b>
<b>Height</b>	<b>1218 mm</b>

**Table 1: DN30 Main Characteristics**

**DROP TEST SEQUENCES**

The performed drop test sequences are shown in the following figures 2 to 6. The tests were performed at room temperature.

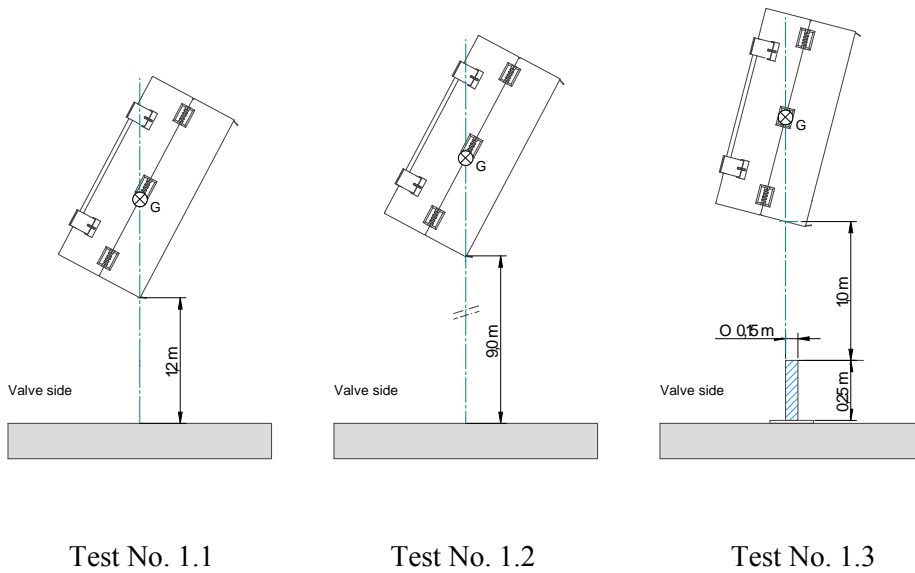

**Figure 2: Test sequence No. 1**

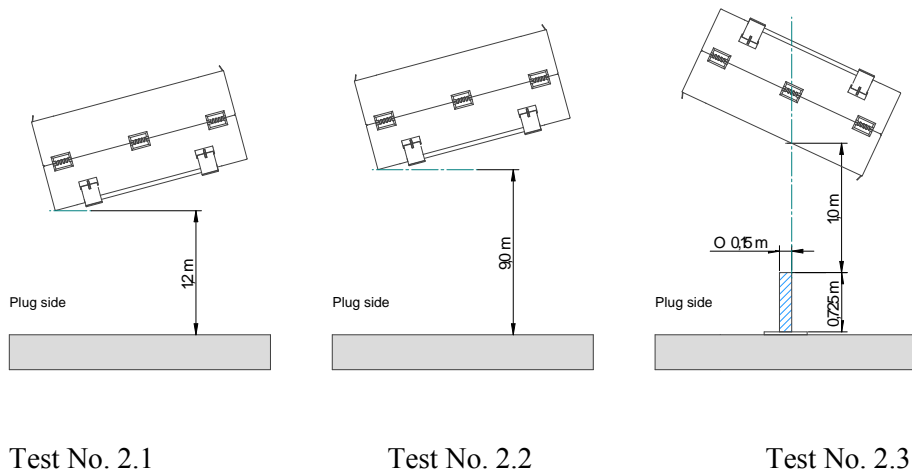

**Figure 3: Drop test sequence 2**

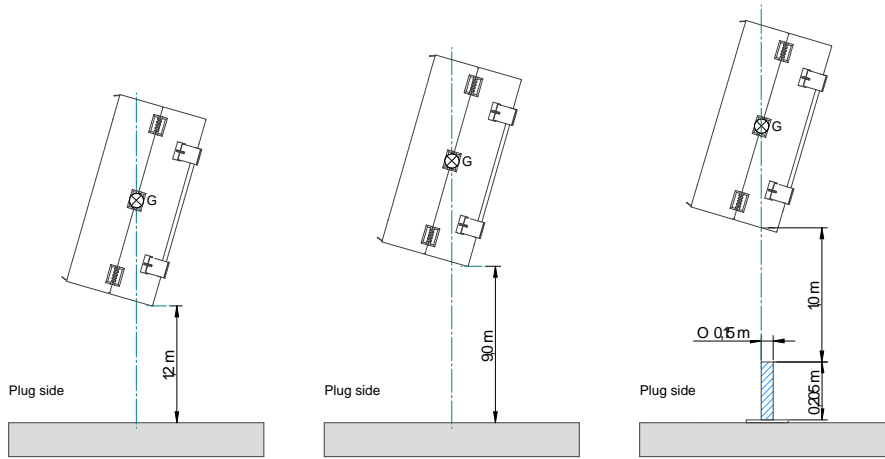

Test No. 3.1

Test No. 3.2

Test No. 3.3

**Figure 4: Drop test sequence 3**

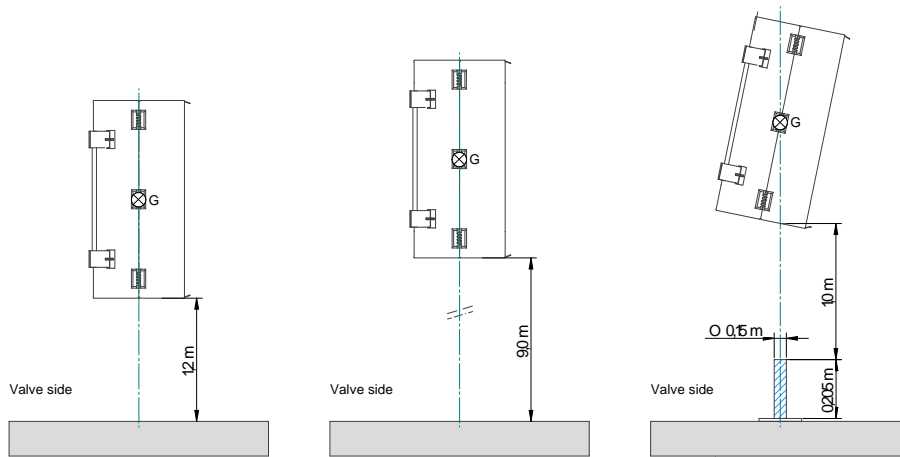

Test No. 4.1

Test No. 4.2

Test No. 4.3

**Figure 5: Drop test sequence 4**

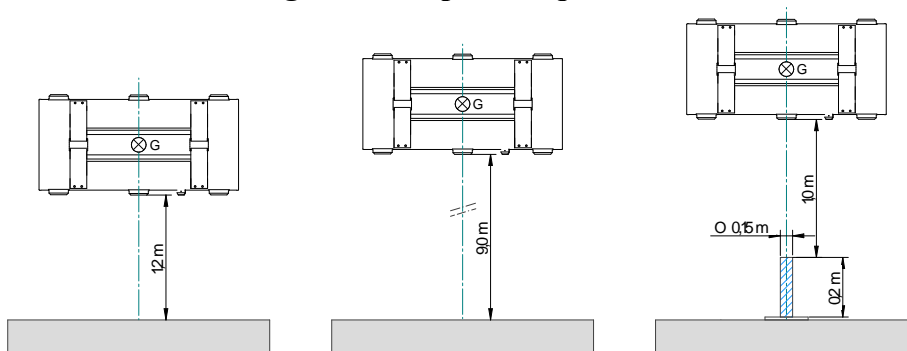

Test No. 5.1

Test No. 5.2

Test No. 5.3

**Figure 6: Drop test sequence 5**

## **TESTS AND MEASUREMENTS**

Tests and measurements were performed before, during and after the tests.

### **Tests and measurements before the drop tests**

Before the performance of the drop tests visual and dimensional controls of 30B cylinders and DN30 prototypes, a control of the valve and plug mounting/torque control of the 30B cylinders, a helium leak test of the 30B cylinders and a weight control of the 30B cylinders, of the DN30 prototypes and of the assemblies were performed.

Just before the tests a control of the accelerometers mounted on the 30B cylinders and a control of the drop height and angle were performed.

### **Tests and measurements during the drop tests**

During the tests high-speed video recordings and acceleration measurements were performed.

### **Tests and measurements after each test**

After each test an exterior visual and dimensional control and a check of the closure system were performed.

### **Tests and measurements after each test sequence**

After completion of each test sequence visual and dimensional exterior and - after opening the DN30 - interior controls were performed. The position of the 30B cylinder inside the DN30 PSP was documented, gaps measured and valve/plug were controlled for contact with the DN30 PSP (contact foil).

After this a helium leak test of the 30B cylinder was performed and the torque of valve and plug and of their threads were controlled.

## **INSTRUMENTATION**

For each drop test sequence the 30B cylinder was equipped with two piezoresistive accelerometers (frequency response 0 Hz to 4000 Hz), the first uniaxial and the second triaxial. In addition a redundant accelerometer was mounted.

## **RESULTS OF THE DROP TESTS**

In the following the results of the five drop test sequences are described.

### **Drop test sequence 1 (corner drop valve side)**

The outer shell of the DN30 was deformed due to the 9 m drop test and 1 m bar drop test. The outer shell showed no cracks (see Fig. 7). No visual damage of the closure system occurred. No contact between valve/plug and DN 30 PSP (see Fig. 8) took place. In the interior the upper half-shell was locally deformed at the valve related front end. The 30B cylinder showed no visual damage. The measured leak rate was acceptable.

The maximum deceleration during the 9 m drop test was in the range of 300 g (cut-off frequency 292 Hz)



**Figure 7: Exterior deformation**



**Figure 8: View of the valve**

### **Drop test sequence 2 (slap down onto PSP feet, first impact plug side)**

The feet and the outer shell on valve and plug side were deformed due to the 9 m drop test. Punctured shell due to 1 m bar drop (see Fig. 9).

Openings between upper and lower half-shell at their front ends were detected which were so small that no gap to the inner 30B cylinder existed.

There was no visual damage of the closure systems C1 to C5. Closure system C6 near the valve side was broken. All closure pins were undamaged and upper and lower half-shell were securely connected. No contact between valve/plug and DN 30 PSP occurred.

The interior of the lower half-shell was locally deformed by the puncture bar and the 30B cylinder showed a small dent due to the bar drop test. The leakage rate of the 30B cylinder was acceptable.

The maximum deceleration during the 9 m drop test was in the range of 300 g (cut-off frequency 292 Hz).



**Figure 9: DN30 after bar drop**



**Figure 10: View of the valve**

### Drop test sequence 3 (corner drop plug side)

The outer shell was deformed due to the 9 m drop test and 1 m bar drop test. No cracks in the outer shell were detected (see Fig. 11). A small opening between the upper and lower half-shell occurred at the plug side. This opening allowed no direct contact to the inner 30B cylinder.

There was no visual damage of the closure system apart from small distortions of the two closures in the impact zone. No contact between valve/plug and DN 30 PSP was detected (see Fig. 12). The interior of the upper half-shell was locally deformed at the plug related front end by the impact of the 30B cylinder and the puncture test. The 30B cylinder showed no visual damage. The measured leakage rate was acceptable.

The maximum deceleration during the 9 m drop test was in the range of 200 g (cut-off frequency 292 Hz)



Figure 11: Exterior deformation

Figure 12: View of the plug

### Drop test sequence 4 (vertical onto the valve side)

The outer shell showed a relatively small buckling due to the 9 m drop test and a dent due to the bar drop test. No cracks in the outer shell occurred (see Fig. 13). There was no visual damage of the closure system apart from small distortions of the two closures in the impact zone (these two pins had to be removed by hammer). No opening between upper and lower half-shell. No contact between valve/plug and DN 30 PSP was detected.

The interior front plate was locally deformed at the valve related front end by the impact of the 30B cylinder and there were local deformations of the valve protector by internal impact of the 30B cylinder. The 30B cylinder showed no visual damage.

The leakage rate was slightly unacceptable. The location of the leakage was determined by a subsequent bubble test. The indications occurred at the mounting thread and the side port of the valve. By dismounting the valve the loosening torque was measured with 380 Nm. The valve showed imprints of the simulated content (steel balls) on the front end of the spindle (see Fig. 14)

The maximum deceleration during the 9 m drop test was in the range of 800 g (cut-off frequency 292 Hz).



**Figure 13: Exterior deformation**



**Figure 14: Valve spindle with imprints**

### **Drop test sequence 5 (horizontally onto the closure line)**

Strong deformations of the upper and lower half-shell in the region of the impacted closures occurred due to the 9 m drop test (see Fig. 15). Additional deformation of the impacted closure were caused by the bar drop test. No cracks in the outer shell were detected.

The DN30 PSP remained closed. A small opening was detected between the upper and lower half-shell at the valve related end face. This opening allowed no direct contact to the inner 30B cylinder. No opening at the plug related end face. No contact between valve/plug and DN 30 PSP occurred (see Fig. 16)

The interior showed small deformations of the DN30 PSP in the impact area and a deformation of the left frame joint of the valve protector. The 30B cylinder had a small dent at the impact point of the bar.

The leakage rate was unacceptable. The location of the leakage was determined by a subsequent bubble test. The indications occurred at the valve itself. No bubbles occurred at the mounting thread of the valve.

The maximum deceleration during the 9 m drop test was in the range of 800 g (cut-off frequency 292 Hz).



**Figure 15: Exterior deformation**



**Figure 16: View of the valve**



## **LESSONS LEARNED**

The results of the performed drop test sequences showed that the deformation of the outside and inside of the DN30 PSP were acceptable. No significant cracks in the outer shell occurred besides during the bar drop test. The valve and plug protectors worked well and no contact between valve/plug and the DN30 structure occurred. The closure system was in all cases intact.

During the horizontal slap-down drop test (sequence 2) one of the six closures near the second impact side showed cracks, but the top- and bottom-halves of the DN30 were still securely connected by five closures. The result of this test showed that during the horizontal slap-down drop in the closure system the maximum stress occurs compared to the other drop orientations. This is caused by the upward movement of the 30B cylinder during secondary impact. To avoid this issue a new material with higher ductility was selected for the new design.

During the flat vertical drop onto the valve side (sequence 4) and the flat horizontal drop onto the closure line decelerations were measured which were in a range of approx. 800 g. These caused a failure of the valve and unacceptable leakage rate. A comparison of the test results with the earlier finite-element calculations showed that the deformations during the drop tests were much lower than predicted by the calculations resulting in much higher decelerations as expected. The reason for this was that the dynamic compression strength of the foam which was directly injected into the DN30 structure was higher as expected from measurements on sample cubes. The lesson learned was that an adequate quality control of directly injected foam is rather difficult if not impossible. Hence the foam parts are now prefabricated and quality controlled before they are mounted into the DN30 steel structure.

In some of the drop test sequences a rotation of the cylinder inside the DN30 was observed. This rotation was stopped in the tested design by the contact of the lugs for the valve cover and the valve protector. To improve the design it was decided to have a strong and dedicated anti-rotation device.

As a result some of the already performed drop tests have to be repeated. These new tests will start in September 2013.

## **CONCLUSION**

The drop test series performed with five prototypes of the DN30 PSP has shown that the principle design of the DN30 PSP is able to withstand the mechanical impact under normal and accidental conditions of transport. After a change of the used foam material DAHER-NCS expects that the new drop tests which are planned for the near future will show that also the requirements concerning leak tightness will be fulfilled for all drop test orientations.

## **REFERENCES**

- [1] F. Hilbert, W. Bergmann, F. Noyon, The DN30 Overpack – A New Solution for 30B Cylinders, PATRAM 2010
- [2] T. Breuer, S. Ricchetti, S. Offermanns, Qualification Test Program of Polyisocyanurate Rigid Foam for the Use in Type B(U)F Packages, PATRAM 2013