

## THE NEW FRESH FUEL PACKAGE FOR MOX BWR FUEL

**Slade W. Klein**

AREVA Federal Services LLC  
Federal Way, Washington, USA

**Gannon J Johnson**

AREVA Federal Services LLC  
Federal Way, Washington, USA

### ABSTRACT

The Mixed Oxide (MOX) Fuel Fabrication Facility (MFFF) being built near Aiken, South Carolina. This facility will be the major component in the United States' program to dispose of surplus weapon-grade plutonium. The facility will take surplus weapon-grade plutonium, remove impurities, and mix it with uranium oxide to form MOX fuel pellets for reactor fuel assemblies. These MOX fuel assemblies will be irradiated in commercial nuclear power reactors. AREVA Federal Services LLC, is developing a new Type B(U)F-96 package for the transport of fresh MOX Boiling Water Reactor (BWR) fuel fabricated at the new facility.

The package, denoted BWR MOX Fuel Package (BMFP), is designed to accommodate two BWR fuel assemblies in a side by side diamond configuration. The package will meet all regulatory requirements including containment and criticality control while meeting the handling requirements for both the MFFF and the mission reactors. The fuel assembly cladding will provide containment for the MOX fuel pellets. The development of the package was based on lessons learned from fuel and package interaction observed during testing of past fresh fuel packages. Design challenges included: fuel impact protection and geometry control.

Qualification of the package will be performed by full scale testing performed in two steps. A full scale engineering test unit (ETU) has been built and will be drop tested using prototypic fuel. The ETU testing will demonstrate package capabilities and provide a basis for the certification test unit (CTU) which will be used for final qualification. The CTU will undergo structural and thermal testing. The fuel cladding integrity will be demonstrated by leak testing of the fuel cladding following both the ETU and CTU tests. This paper discusses the BMFP design challenges and the unique design features that allow the user to realize the benefits of using a lightweight transport package.

### INTRODUCTION

In 1999, the National Nuclear Security Administration (NNSA) contracted with a consortium now called Shaw AREVA MOX Services, LLC to design, build, and operate a Mixed Oxide (MOX) Fuel Fabrication Facility (MFFF) as part of the United States' program to dispose of surplus weapons-grade plutonium. The MFFF is being built on the Department of Energy's Savannah River Site near Aiken, South Carolina. The facility will utilize surplus weapons-grade

plutonium, remove impurities, and mix it with depleted uranium to form MOX fuel pellets for reactor fuel assemblies. These MOX fuel assemblies will then be transported to commercial nuclear power plants for irradiation. The design of the MFFF is based on AREVA's proven MELOX and La Hague facility designs. AREVA has utilized MOX technology in France with great success, and currently supplies MOX fuel to commercial power reactors throughout the world. Once completed, the MFFF will be capable of processing up to 3.5 metric tons of weapons-grade plutonium into MOX fuel assemblies each year.

AREVA Federal Services LLC (AFS), associated with the Business Unit Logistics of AREVA, was contracted by Shaw AREVA MOX Services, LLC to develop a new Type B(U)F-96 package for the transport of fabricated fresh MOX Pressurized Water Reactor (PWR) and Boiling Water Reactor (BWR) fuel assemblies from the MFFF to commercial nuclear power reactors, known as mission reactors. Separate packaging was designed for the PWR and BWR fuel types. This paper discusses the design considerations, packaging development, packaging configuration, and licensing of the AFS BWR MOX Fuel Package (BMFP). BMFP engineering test units (discussed below) have been fabricated, but testing is currently on hold. ETU testing must be completed before a certification test unit design may be finalized. Therefore, this paper is limited to discussing the BMFP ETU design.

## **DESIGN CONSIDERATIONS**

For packaging design that includes the containment safety function, existing designs of fresh fuel Type B fissile transportation packages have generally included a separate leak testable containment boundary with no reliance on the structural integrity of the fuel rod cladding for containment. These current designs do present some efficiency and operational related drawbacks for transporting MOX fuel assemblies. A limited number of fuel assemblies would be transported per package, and the weight and size of the packaging is such that only one or two packages could be placed on a conveyance. In addition, a separate fuel basket must be designed and fabricated to insert and remove the fuel. Multiple pieces of auxiliary equipment must also be designed and fabricated for loading and orienting fuel within the MOX and the mission reactor facilities.

Alternatively, several Type B packages have been licensed using the fuel assembly metallic cladding and end fittings as the containment safety function for enriched uranium oxide fuel (UO<sub>2</sub>) without a separate metallic containment boundary. The advantage to this approach is that packaging can be smaller and lighter in weight. The increase in transportation efficiency offered by a lightweight package led to the decision to design the BMFP using the fuel rod cladding and end fittings as the containment boundary.

The design must still satisfy all of the required regulatory requirements, which makes maintaining the integrity of fuel rod cladding and end fittings critical. Because of the sensitivity to fuel cladding damage, past structural test results of successfully licensed UO<sub>2</sub> packages were closely studied in the development of the BMFP design. Although these packages passed the required leakage rate testing for the UO<sub>2</sub> payload, some fuel cladding damage was noted. Fuel damage was observed in the following:

- Packages having little to no end impact protection and lacking fuel assembly axial restraint were susceptible to end drop impact damage that resulted in deformation of the cladding near the lower end fitting resulting in circumferential failure of multiple fuel rods.

- Packages with little fuel cavity envelope restraint and impact protection were susceptible to end drop impact damage that caused fuel rod movement and cladding damage from fuel rods protruding around the lower end fitting.
- Packages that were very stiff and had inadequate impact mitigation experienced damage from oblique drops that caused fuel rod bending followed by constraint which resulted in side loading and longitudinal cladding cracking in regions of rod-to-rod contact.

This information was used to optimize the BMFP design to mitigate the risk of fuel rod damage. Other design goals for the packaging included:

- Licensing as a Type B(U)F-96 package for the MOX fuel
- Maximize transportation efficiency
- Packaging must accommodate multiple BWR designs/lengths
- Designed for loading at the MFFF
- Designed for unloading at mission reactors with maximum similarity to existing UO<sub>2</sub> fuel handling procedures.

## **PACKAGING DEVELOPMENT**

Design challenges for the packaging included impact protection and fuel assembly geometry control. The packaging must meet all regulatory requirements, including 30-foot free drop testing. This test is of special concern because the fuel rod cladding and end fittings provide the packaging containment safety function. The MOX fuel assemblies were evaluated to establish structural acceleration limits, based on past testing results. The fuel acceleration limits were then used for sizing the packaging impact protection. Impact protection was based on past UO<sub>2</sub> packages and modified for optimization. Four impact absorbing spacers were welded to the top and bottom of the BMFP and an elongated impact limiter was attached to each end of the packaging (Figure 1). The spacers and impact limiters are constructed from stainless steel sheet metal enclosing rigid, closed-cell polyurethane foam. This configuration is predicted to drastically reduce the fuel assembly deceleration impact loading, thus mitigating the potential failure of the containment boundary. Most of the damage in past testing has been due to end free drop events. The end impact limiter was designed as a trapezoidal shape with a large available stroke. These combined features will result in a low level of acceleration impact loading being transferred to the fuel assemblies.

Controlling the fuel assembly geometry is also required for criticality control, and to restrict possible fuel damage due to lateral or axial expansion. Criticality control is achieved by providing a sufficient spacing between adjacent fuel assemblies and other packages. This spacing is provided by the fuel bed design. The fuel assemblies are placed into a W-shaped fuel bed and are secured by hinged V-shaped fuel doors that provide lateral and vertical support along the entire length of the fuel assembly (Figure 2). The doors are secured using adjustable latches and expansion is further controlled by the close fitting lid design that does not allow significant lateral movement. The fuel assemblies are restrained axially by the fixed bottom plate, and a removable and adjustable upper end restraint bar. These features have been sized to support the predicted applied free drop impact loading, and will ensure the fuel geometry is controlled throughout a free drop event.

The BMFP does not require any biological shielding beyond that which is provided by the package structural materials to meet the regulatory requirements for exclusive use transport trailers.

Thermal protection is provided by the rigid polyurethane foam and ceramic fiber paper between the outer and inner shells of the lid and base assemblies. Polyurethane foam combined with ceramic fiber paper as external protection has been shown in previous package testing to provide excellent thermal protection during the regulatory thermal (fire) event [1].

## **PACKAGING CONFIGURATION**

The BMFP (Figures 1 and 2) is a lightweight packaging consisting of a base assembly, a lid assembly with two end impact limiters, and eight impact absorbing spacers (four on the lid and four on the body). The base consists of a fixed, stainless steel strongback that supports the fuel assemblies in a side-by-side diamond configuration (Figure 3). The W-shaped strongback is secured in the base using a riveted construction through a fiberglass thermal break. The strongback is connected to the outer shell with two full-length structural angles. The outer shell is 0.120-inch (3.05 mm) thick stainless steel sheet. Enclosed between the strongback and the outer shell is a layer of rigid polyurethane foam. The base is equipped with four external impact absorbing spacers designed to allow stacking. The spacers are 0.105-inch (2.67-mm) thick stainless steel shells enclosing the rigid polyurethane foam. The fuel assemblies are placed in the W-shaped strongback, and each assembly is secured in-place by five aluminum fuel doors down the length of the base. The lid construction is very similar to that of the base with a W-shaped stainless steel inner shell fitted closely to the fuel doors, a layer of rigid polyurethane foam, and a 0.120-inch (3.05-mm) thick stainless steel outer shell. The lid is also equipped with four external spacers, and trapezoidal impact limiters at each end. The impact limiters are constructed from 0.120-inch (3.05-mm) thick stainless steel enclosing rigid polyurethane foam. The polyurethane foam in the lid and the base is insulated from the outer shell with two layers of ceramic fiber paper. The lid and the base, which are secured together with (52) ball lock pins, form a stepped joint with a fibrous high temperature seal to prevent ingress of high temperature gases in the a fire event.

The packaging has an overall length of 227 inches (5.77 m), a width of 53 inches (1.35 m), and a height of 36 inches (0.91 m). The gross weight of the loaded package is approximately 6,200 pounds (2812 kg). The package is equipped with lift points for handling by crane or can be lifted by a forklift. The components may be lifted assembled or individually.

The fuel assembly payload consists of two types. The principle payloads are the ATRIUM™ 10 or ATRIUM™ 10XM MOX BWR fuel. Additional future payloads may include ATRIUM™ 11 BWR fuel.

The BMFP facility footprint is minimized by the stacking feature built into the packaging. The packages are designed to be stacked vertically, as shown in Figure 4. The figure depicts the eight-pack of BMFPs placed on a standard highway flatbed trailer. The package is designed to be secured by straps during transport. Shear continuity is provided between packaging by use of four indexing lugs located on the top end of each package, and interfacing with pockets on the bottom of the package.

## **PACKAGING LICENSING DEMONSTRATION**

A “license by test” approach was chosen for the new packaging. The primary technical challenge for certifying the BMFP design is ensuring that the fuel rod cladding, which provides the containment safety function, maintains its structural integrity for all applicable regulatory tests, i.e., free and puncture drops, and thermal. For the design to be successful, impact and thermal damage to the fuel rod cladding that could result in failure of the cladding must be prevented. The BMFP design is based on past successfully licensed fuel packages plus design enhancements made to decrease impact forces and mitigate the risk of fuel cladding damage. Since fuel rod cladding has not been generally required to provide the containment safety function for a licensed package, extensive testing of prototypic fuel assemblies will be performed. The process will involve development and drop testing of engineering test units (ETUs) to clearly determine packaging vulnerabilities and worst-case test orientations prior to the final design and fabrication of certification test units (CTUs). The ETU test results will provide an engineering verification of the predicted impact forces and permit any final design changes prior to performing certification testing. The ETUs will be drop tested. The CTUs will undergo a complete regulatory hypothetical accident condition (HAC) sequence including fire testing. The packaging will be tested at bounding temperatures and fitted with active instrumentation to determine impact accelerations.

The drop tests will include four-foot normal condition of transport (NCT) free drops, 30-foot (9-m) HAC free drops, and 40-inch (1 m) puncture drops, as required by Title 10, Code of Federal Regulations, Part 71 (10 CFR 71). Since the containment safety function is dependent on the integrity of the fuel rod cladding, certification tests will be conducted to demonstrate the structural performance of both the packaging and the fuel assembly. Thus, both the ETU and CTU packaging will be tested utilizing prototypical MOX BWR fuel assemblies. The prototypic fuel assemblies will be leakage rate tested prior to testing, and at the conclusion of the package drop testing. Following the leakage rate testing, the fuel rods will be punctured to demonstrate the presence of helium to validate the leakage rate test, and demonstrate that the cladding integrity was maintained. The prototypical fuel assembly will be fabricated using the same welding and manufacturing techniques that will be used to construct MOX fuel assemblies. To minimize radiological hazards during the testing, tungsten carbide pellets will be used in lieu of MOX fuel pellets.

## **CONCLUSION**

A new packaging has been designed to transport MOX BWR fuel assemblies. The packaging is designed as Type B(U)F and has the capacity for two fuel assemblies. It is lightweight such that eight packages may be placed on a conveyance, providing good transportation efficiency. Because the packaging containment safety function depends on the fuel rod cladding and end fitting integrity, certification testing will be conducted using prototypic fuel assemblies for both the ETUs and CTUs. Currently, two ETUs have been fabricated and testing will be completed in the next phase of the project. Extensive testing will demonstrate the adequacy of the design and for the transport of MOX fuel assemblies.

## **REFERENCES**

1. Criddle, J. Thomas., et al, *Burn Testing of Polyurethane Foam Shielded with Ceramic Fiber Paper*, Proceedings of the 15th International Symposium on the Packaging and Transportation of Radioactive Materials (PATRAM), Miami, Florida 2007.

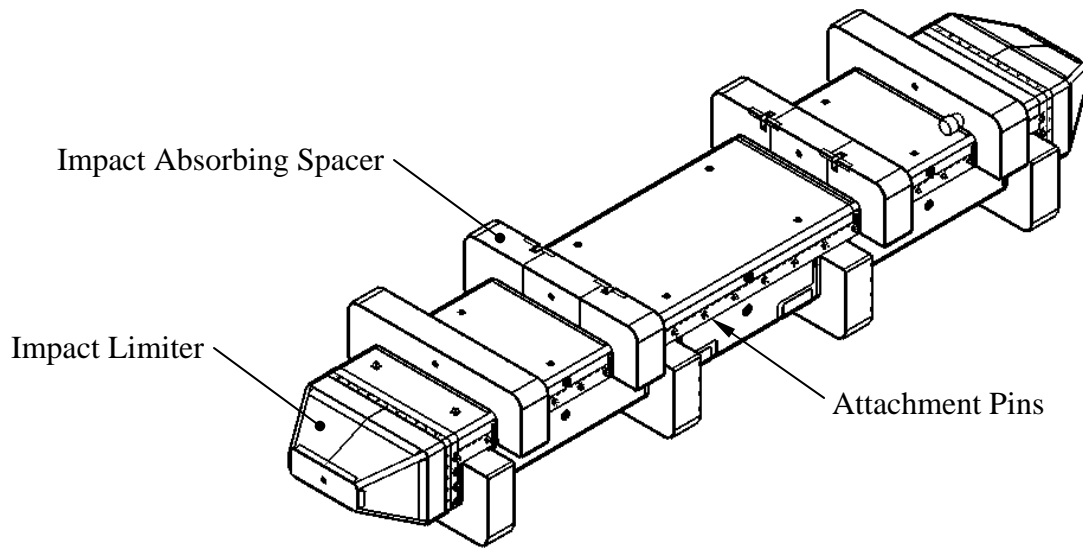

**Figure 1. BMFP Design**

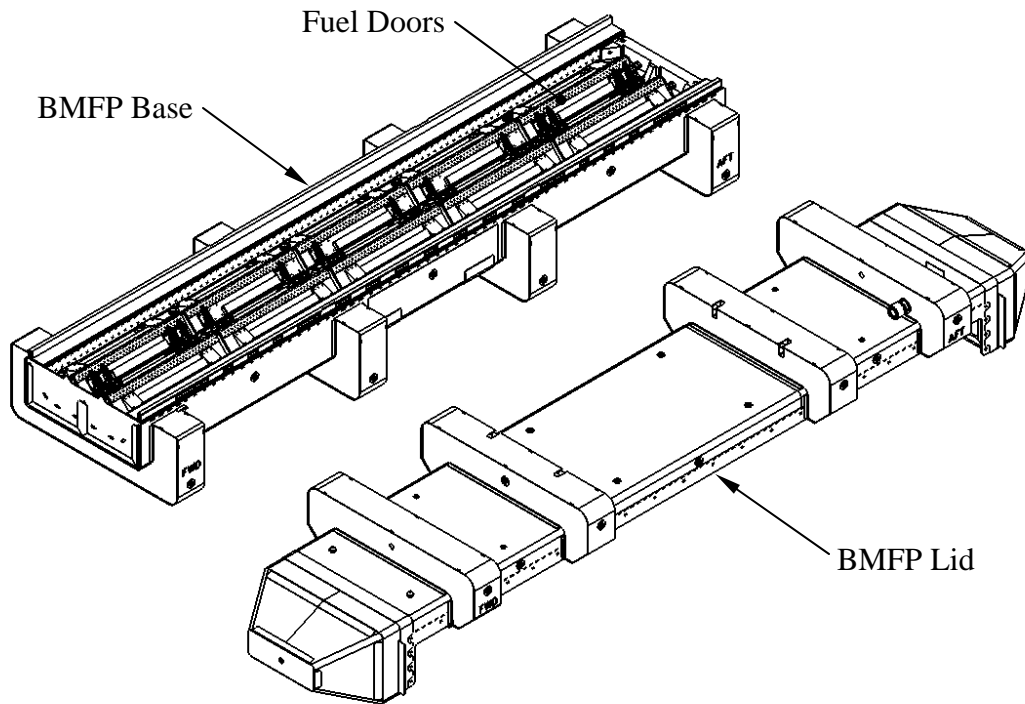

**Figure 2. BMFP Lid and Base**

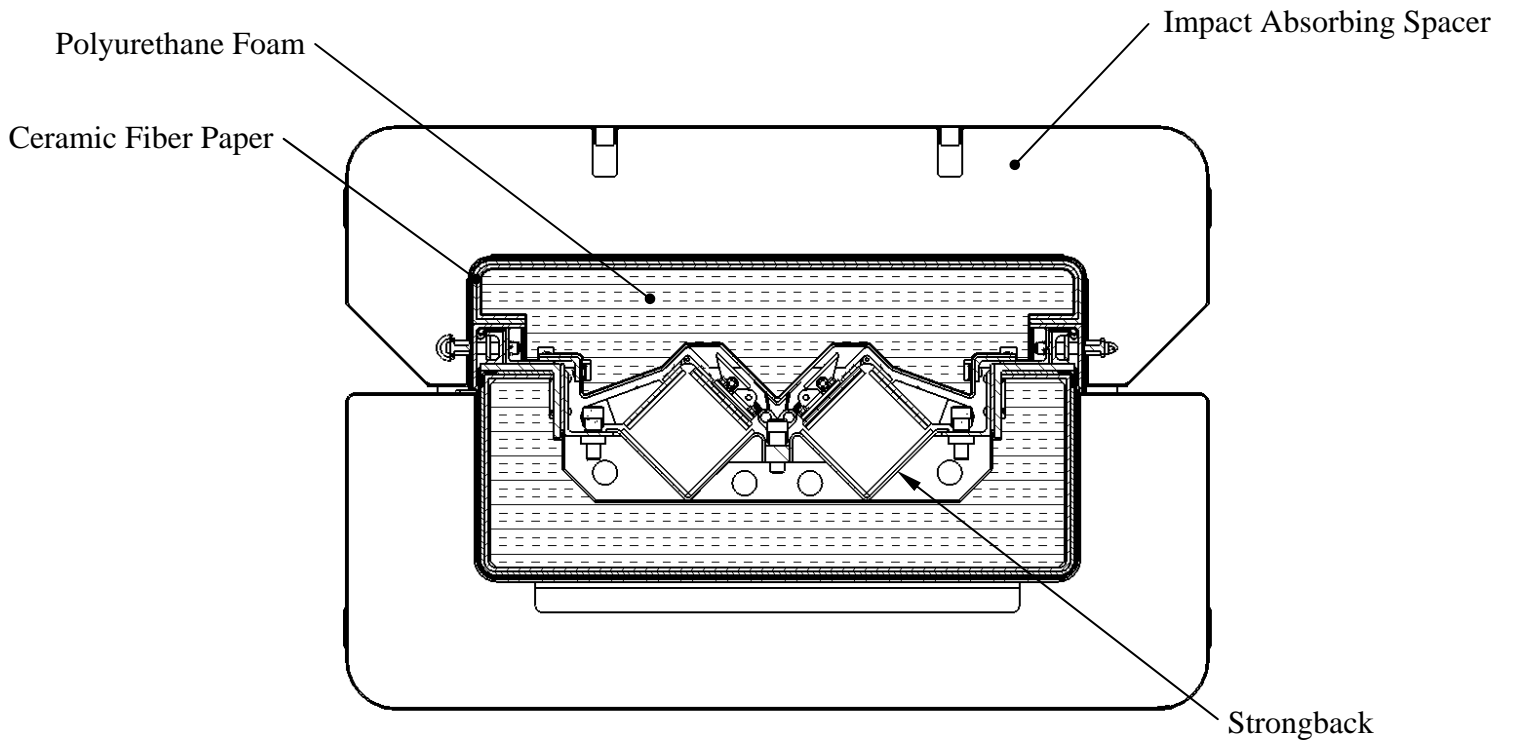

**Figure 3. BMFP Cross-section**

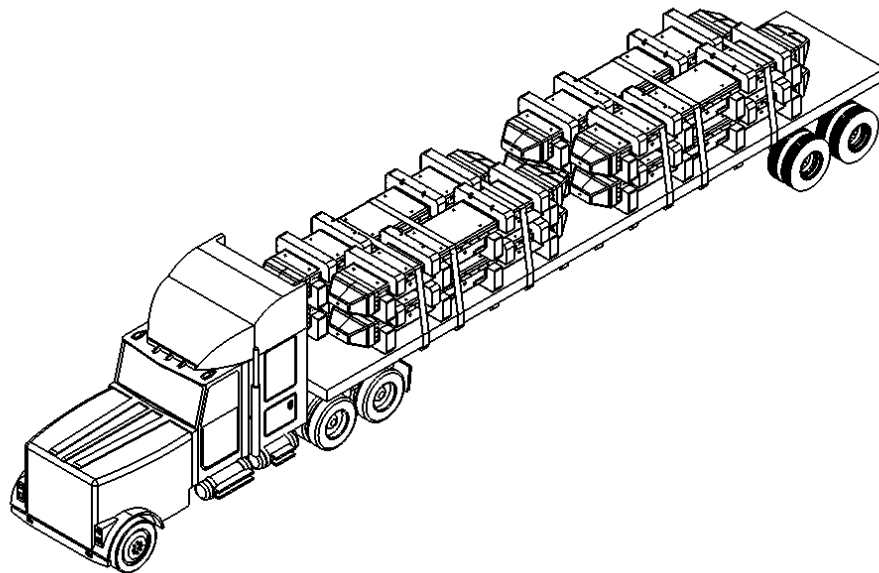

**Figure 4. BMFP Stacked on Conveyance**