

Development of a Specific Activity Distribution Estimation Method for Large Low-level Radioactive Waste Using Shape Measurement Technique

Michiya Sasaki, Haruyuki Ogino and
Takatoshi Hattori

Central Research Institute of Electric Power
Industry (CRIEPI)

Introduction

- Decommissioning of NPP
- Large items of low-level radioactive waste

LSA-II (TS-R-1) when activity is distributed throughout .

- TS-G-1.1 criteria:

Case A

the differences in specific activity between portions of a factor of less than 10 would cause no concern. However, there is no need to assess and compare the specific activity of each of these portions, provided that the estimated maximum average specific activity in any of these portions does not exceed the specific activity limit for solids

Case B

Requirement for LSA-II material

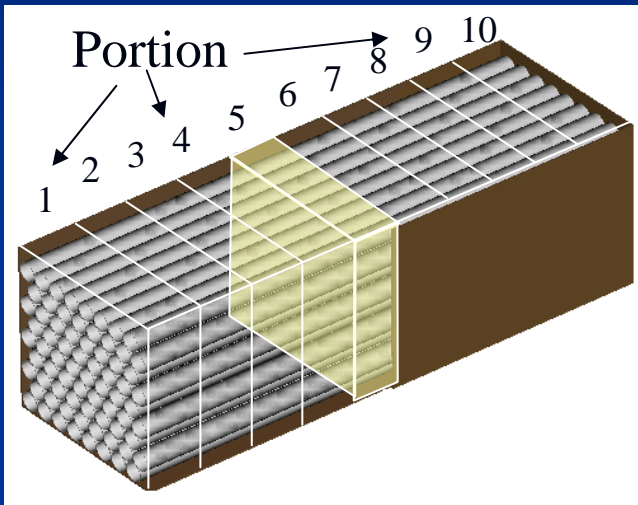

For a volume between 0.2 m^3 and 1.0 m^3 , the volume should be divided into five, and **for a volume greater than 1.0 m^3 into ten parts** of approximately equivalent size

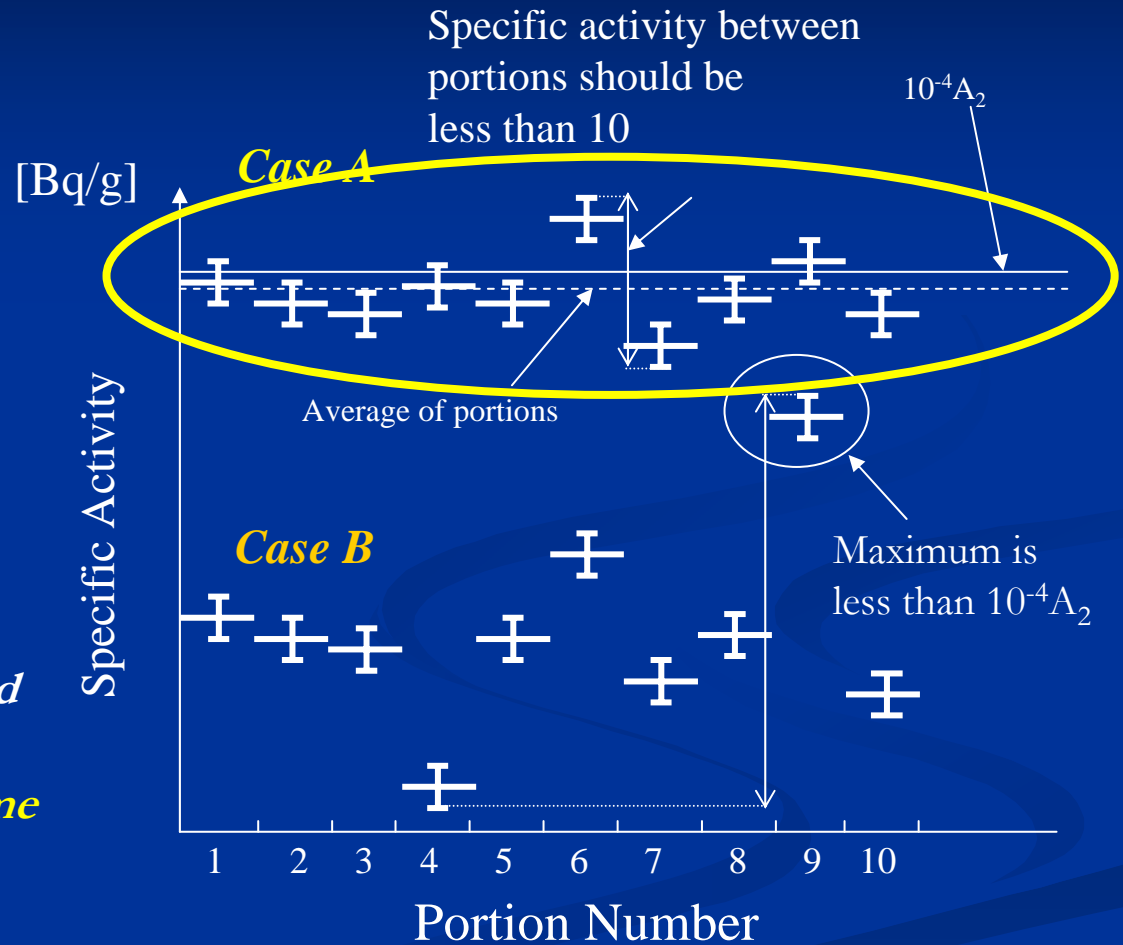

Previous Study

- Simple gamma-ray measurement method for **completed radioactive waste package (PATRAM2007)**
- Compliance with the transport requirement is **impossible** when the filling rate of a large waste package is higher than approximately 10% because of large uncertainty.

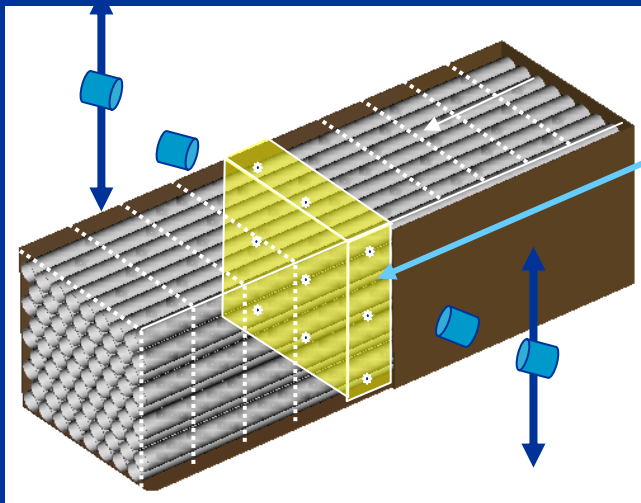

Measurement target:

Portion

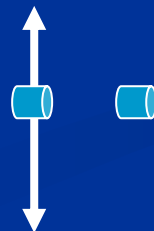

Measurement methods

1. Fixing

2. Scanning

Objectives of This Study

- Development a specific activity distribution estimation system
 - a clearance measurement technique is applied to estimate specific activity with high accuracy.
- The degree of standard uncertainty was evaluated experimentally by using standard radioactive sources and mock-metal-waste samples.
- Applicable scope of this system was clarified for compliance with the transport requirement case A.

Activity Distribution Estimation System

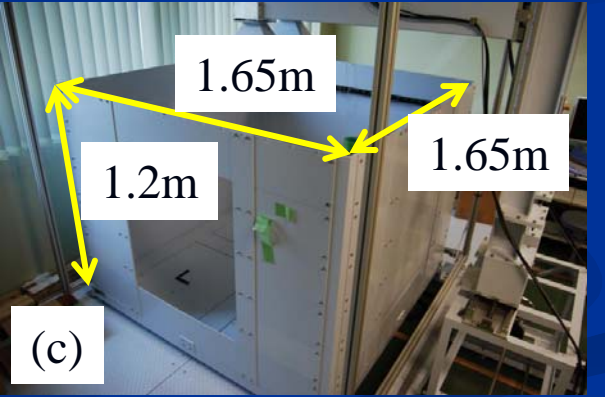
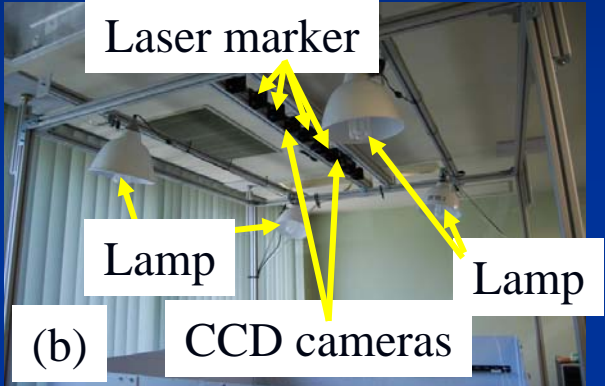
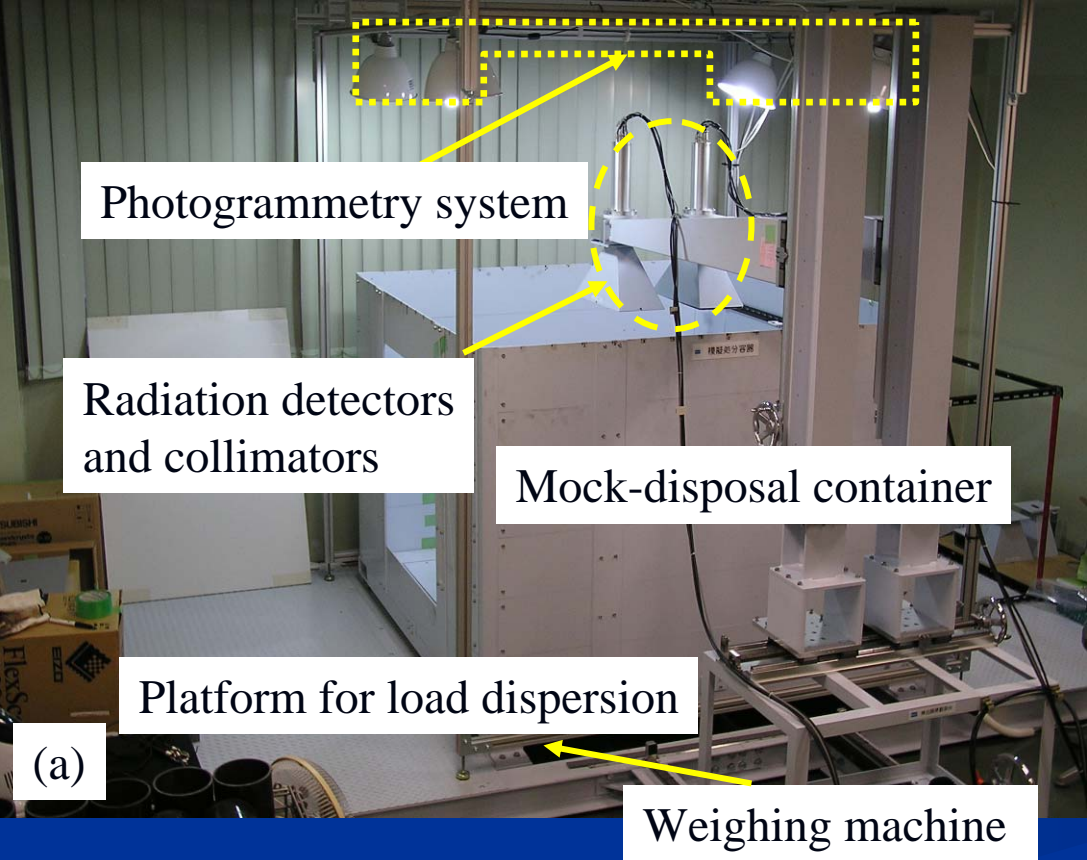

Specific Activity Est

Start

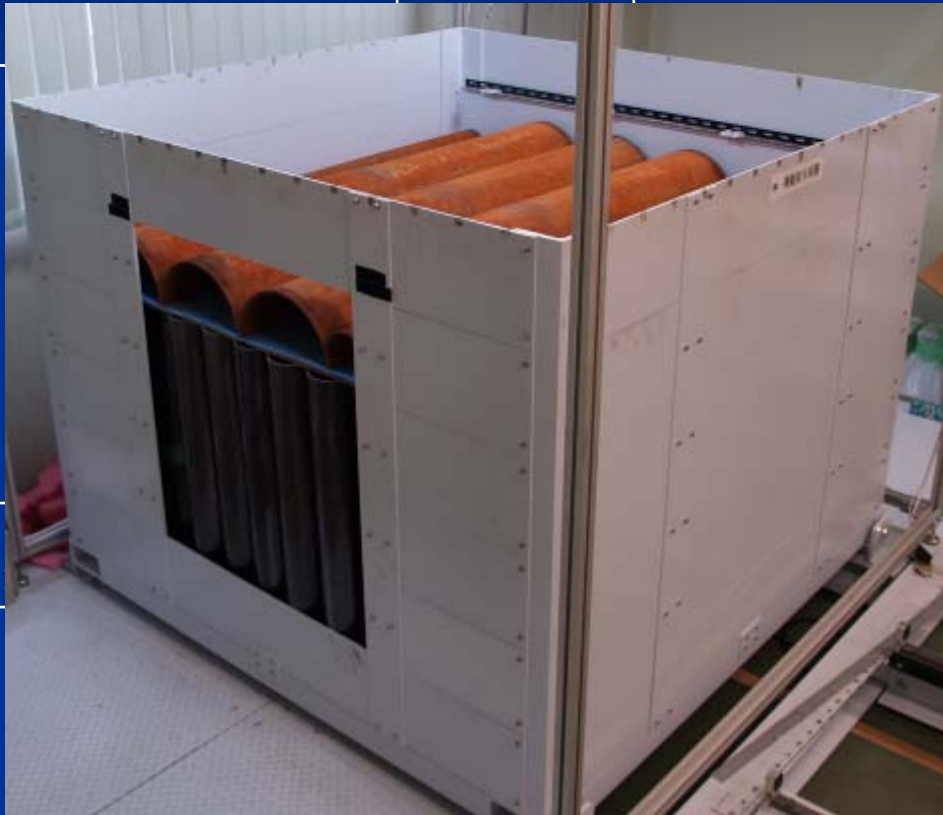

Yes

Add waste?

No

(7)

Specific activity estimation of a portion

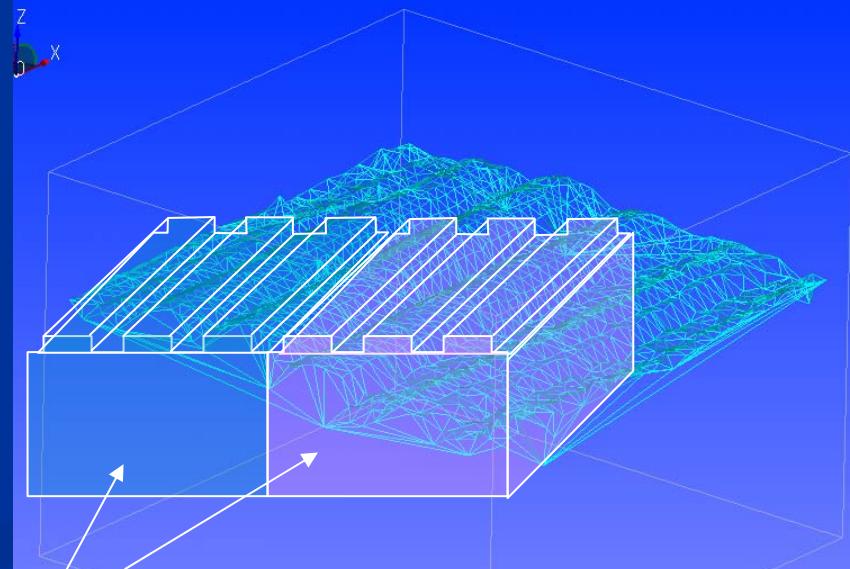
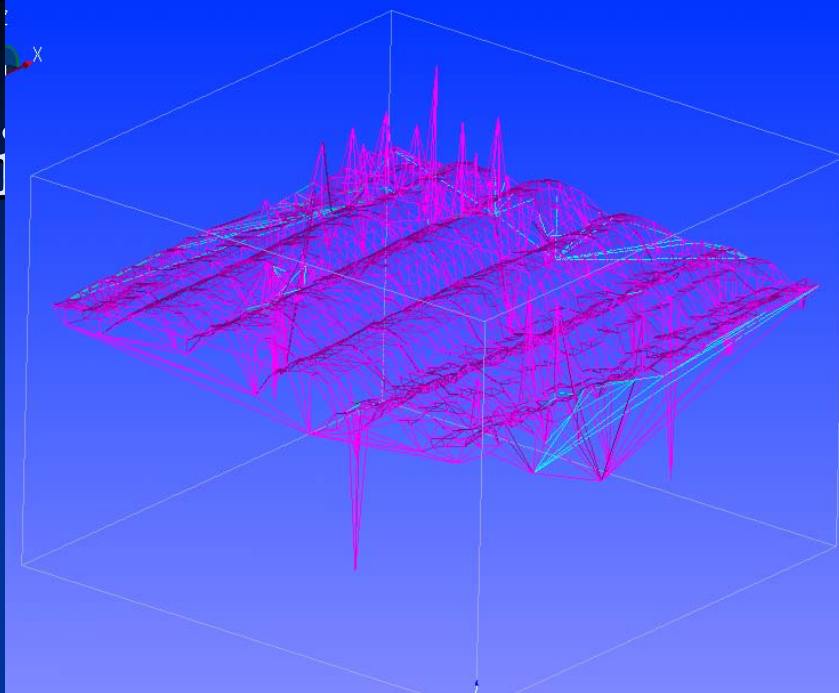

Segment: a part of a portion, regarded as the basic unit in specific activity estimation

Specific Activity Estimation Method

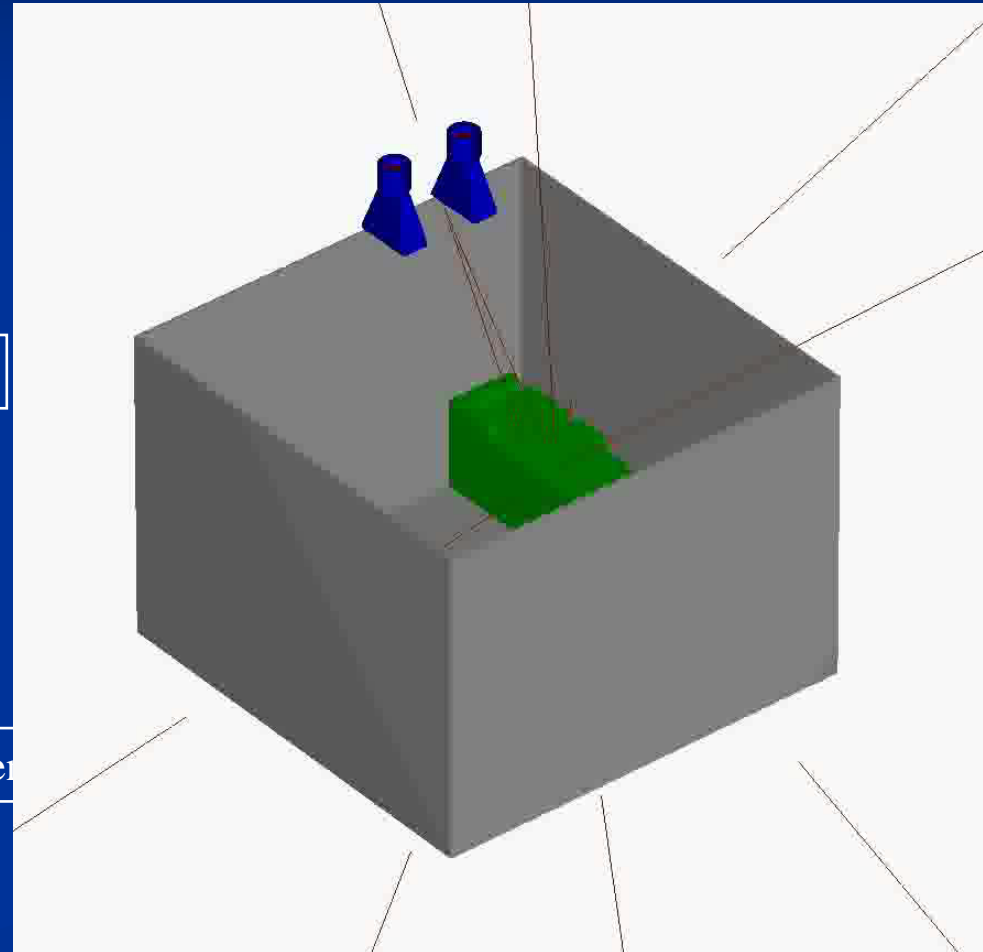
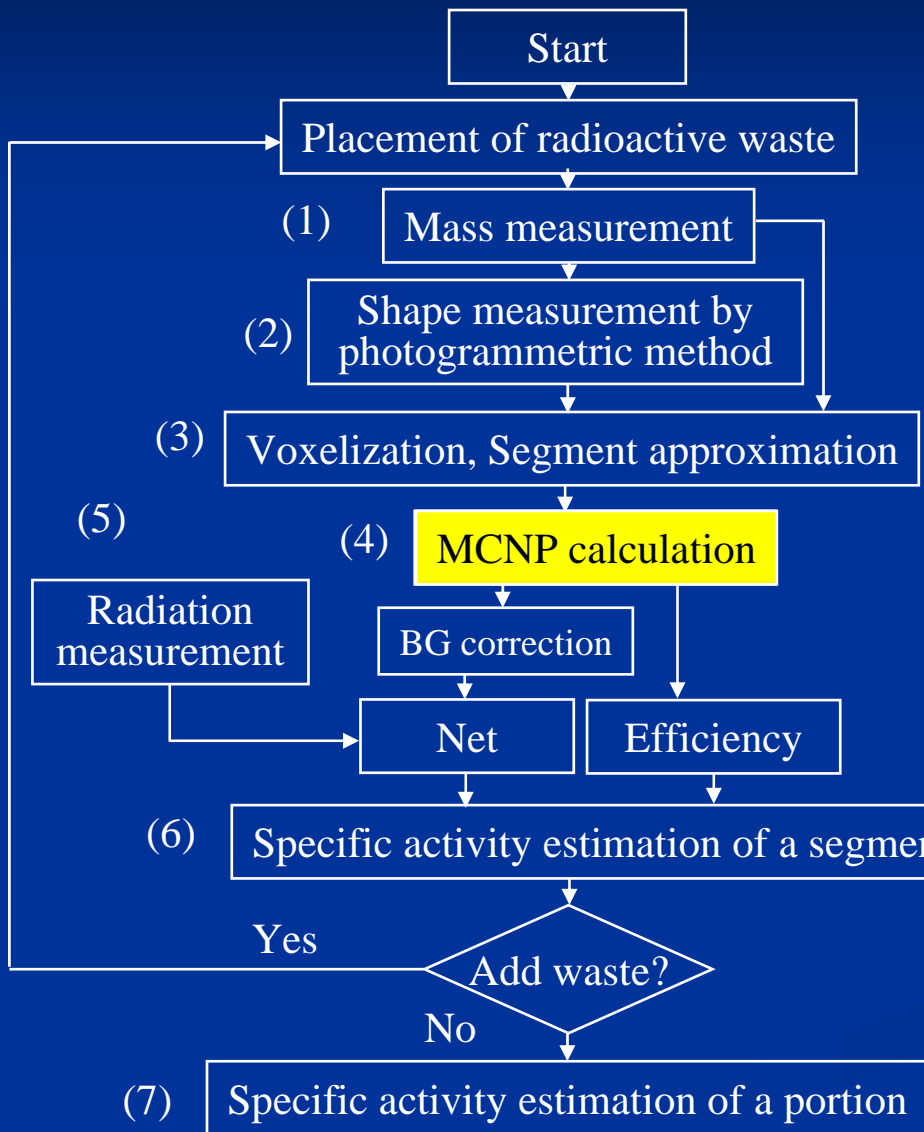

Segment: a part of a portion, regarded as the basic unit in specific activity estimation⁸

Specific Activity Estimation Method

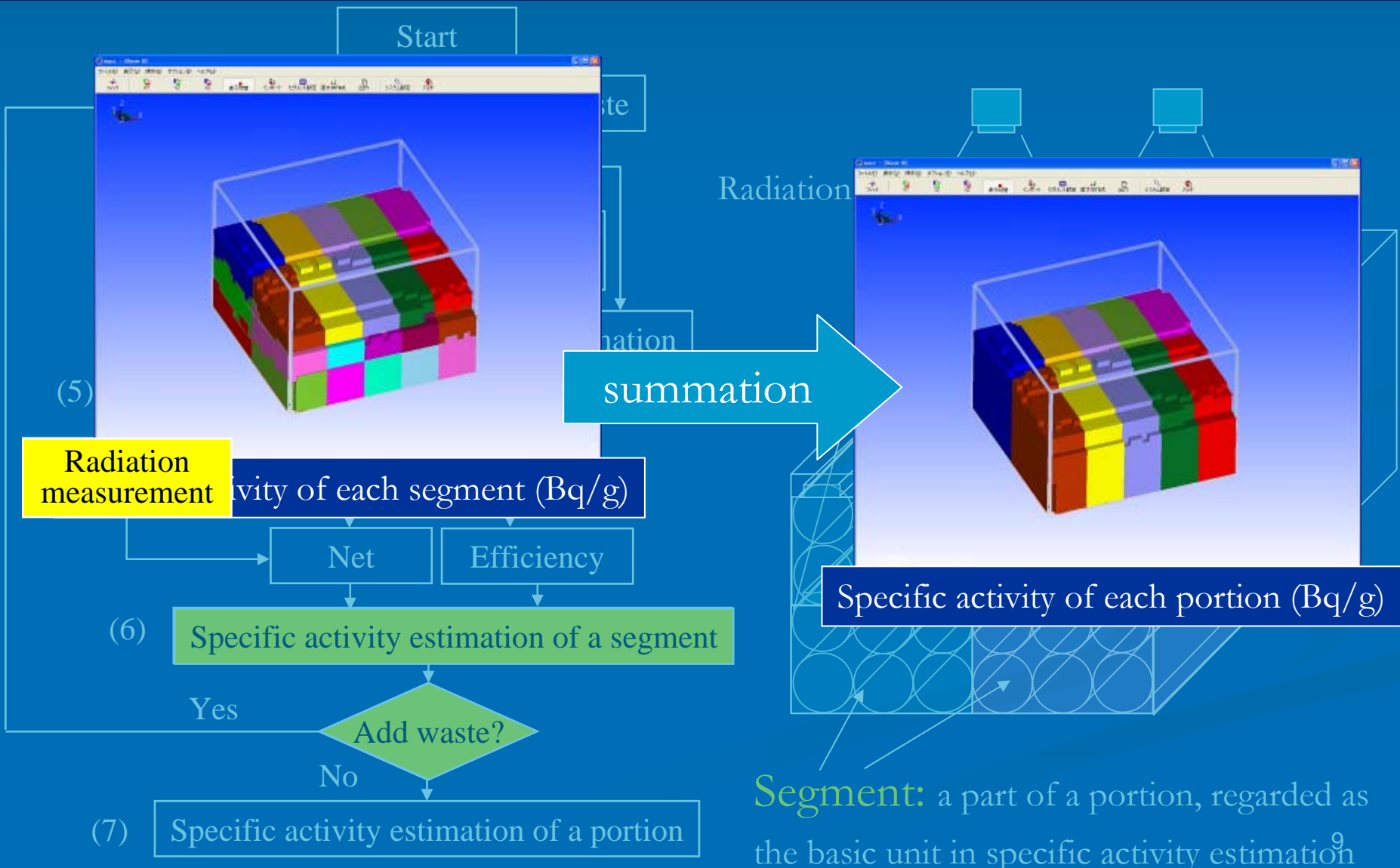

Experiment

- Degree of uncertainty in calibration estimated by varying
 - distance between the radiation detector and the surface of the radioactive waste (d)
 - filling rate of the mock radioactive waste
 - thickness of a segment (T)
 - component of the pulse height distribution (peak, gross)
 - position of a Co-60 standard radioactive source

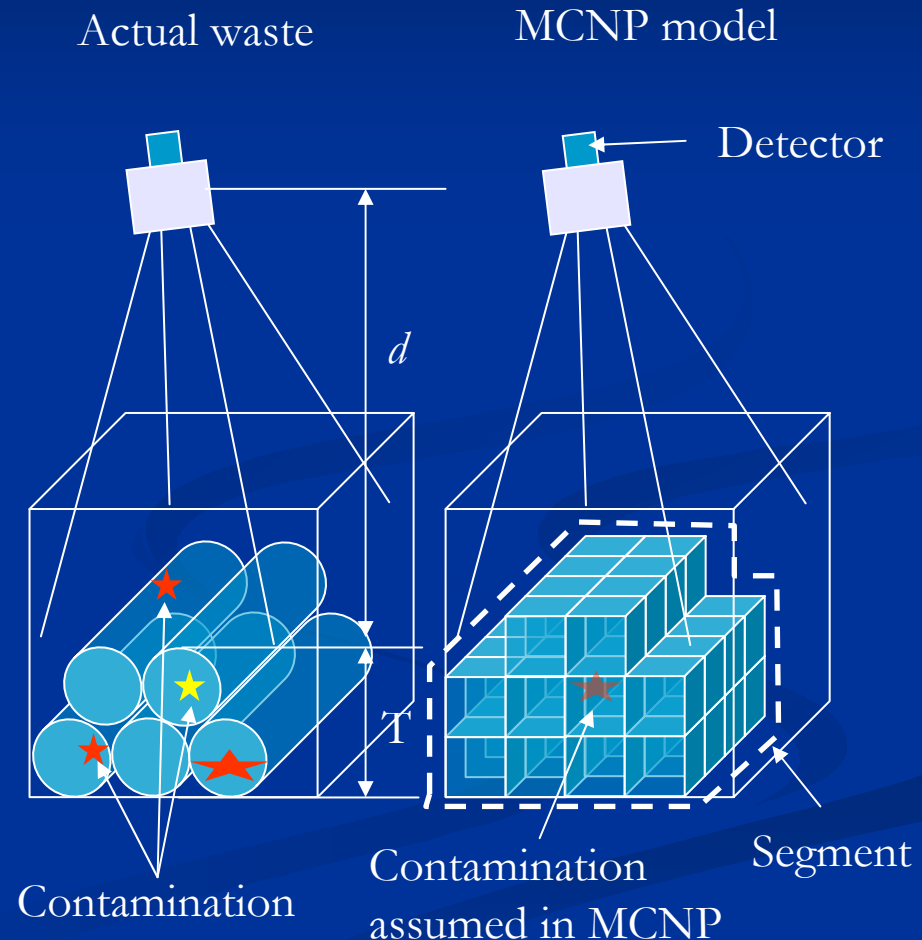

Experimental Parameters

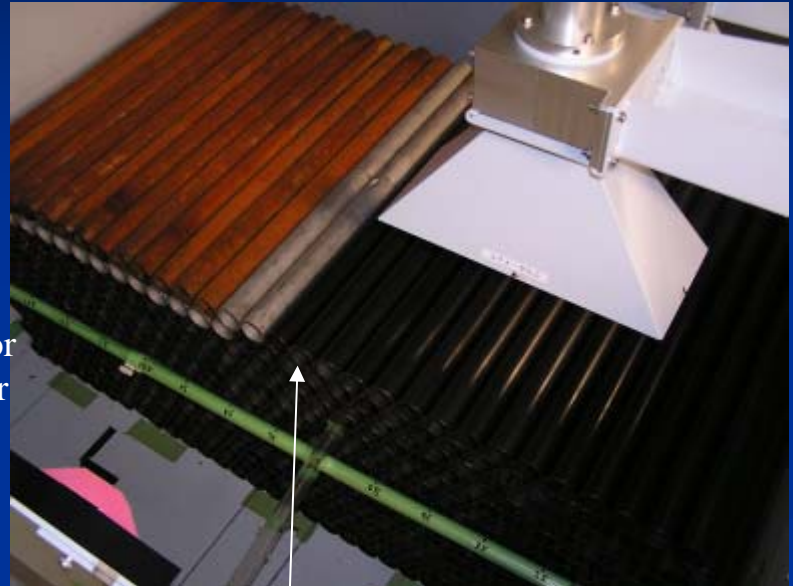
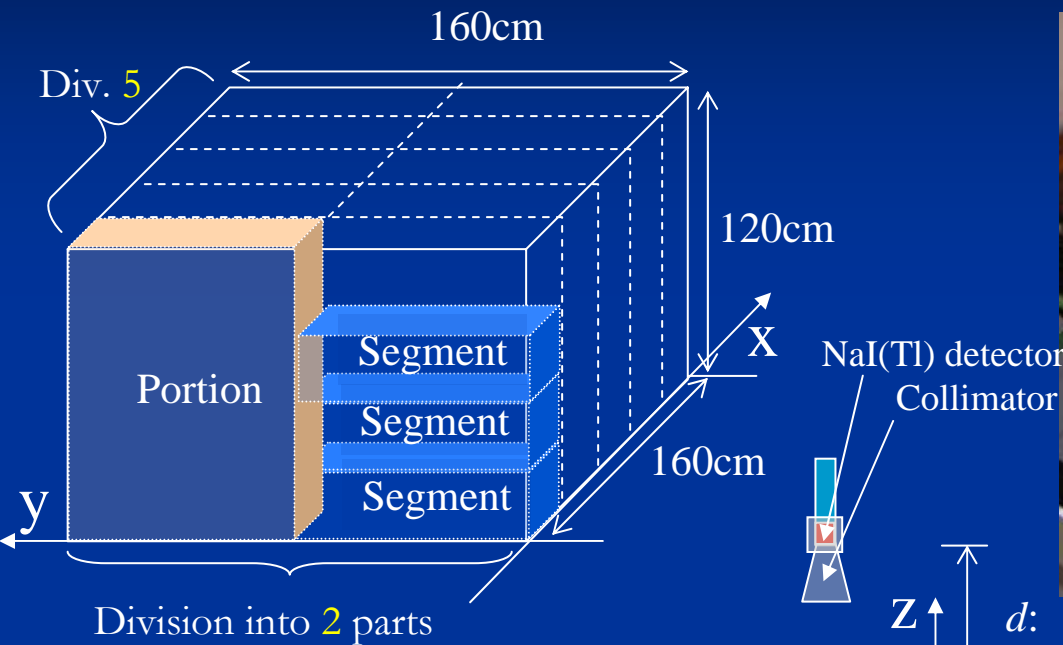

Co-60 source position

- x: 5, 15, 25
- y: 5, 25, 45, 65 (z=5, 25, 45)
- y: 15, 35, 55, 75 (z=15, 35, 55)
- z: 5, 15, 25, 35, 45, 55

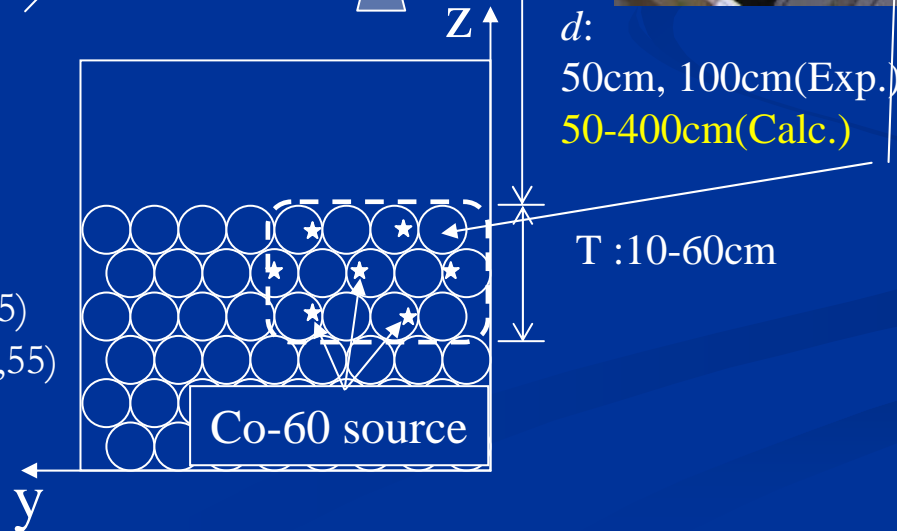

Mock-radioactive waste
JIS 40A, 100A, 250A pipes

Filling rate

250A: 0.075

100A: 0.121

40A : 0.214

Result

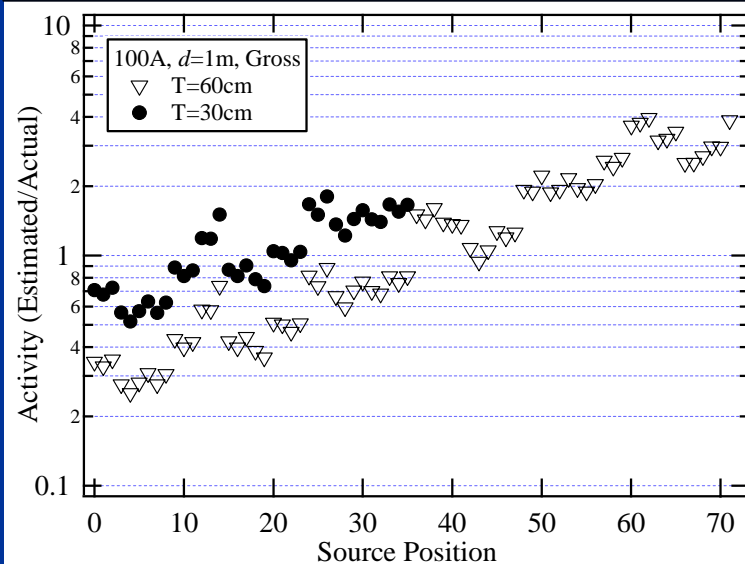
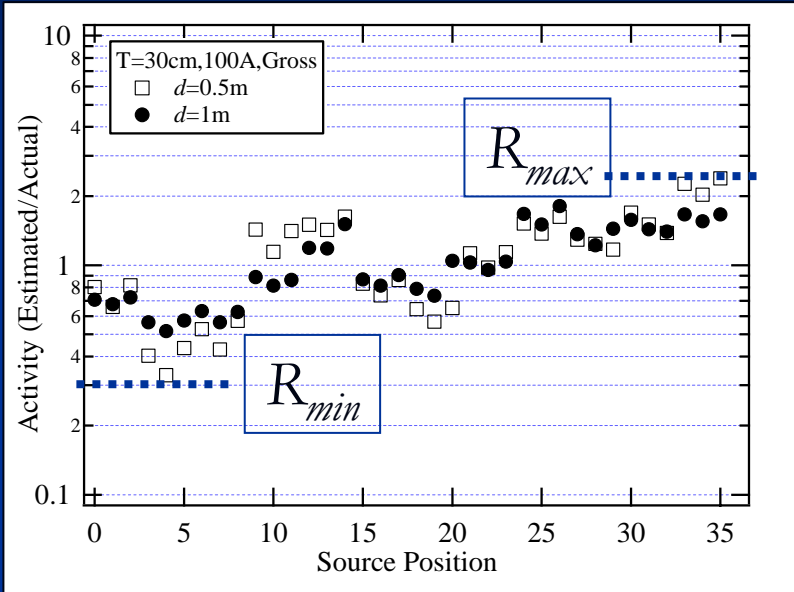

- A greater distance between the radioactive waste and the detector can suppress the uncertainty in calibration
- A thinner segment is preferable for suppressing the uncertainty in calibration. This is due to the decrease in the degree of the shielding effect

The calibration uncertainty factor for the activity estimation of a segment

$$U_f = \frac{\sqrt{R_{max} \cdot R_{min}}}{R_{min}}$$

Estimation of Standard Uncertainties in Activity Estimation of a Segment

- Since contamination exists at various positions in actual radioactive waste, its existence probability is assumed to be spatially homogeneous among a segment.
- The size of a segment can be selected in the placement process, over/underestimates beyond R_{max} and R_{min} never occur.
- Given that the attenuation of radiation can be expressed using exponential functions, a **log-uniform distribution** can be used as the probability distribution for the calibration uncertainty of a segment.

- Guide to the Uncertainty in Measurement, GUM[1], the variation for a uniform distribution, $u^2(x_i)$,

$$u^2(x_i) = a^2/3$$

a : the difference between the maximum (minimum) and its arithmetic mean value

- By adopting this relationship in the log-uniform distribution, the standard uncertainty in the log-uniform distribution:

$$u(x_i) = \exp(\ln(a)/\sqrt{3}) \quad R_{max}$$

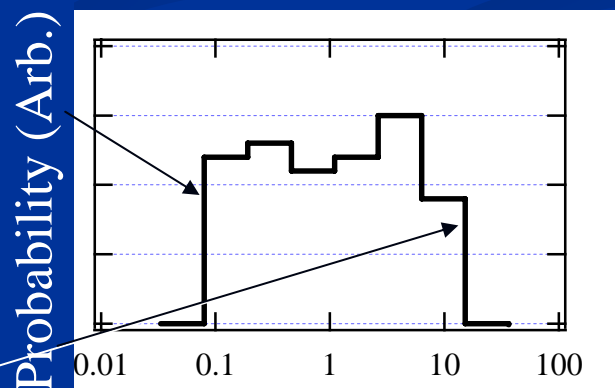
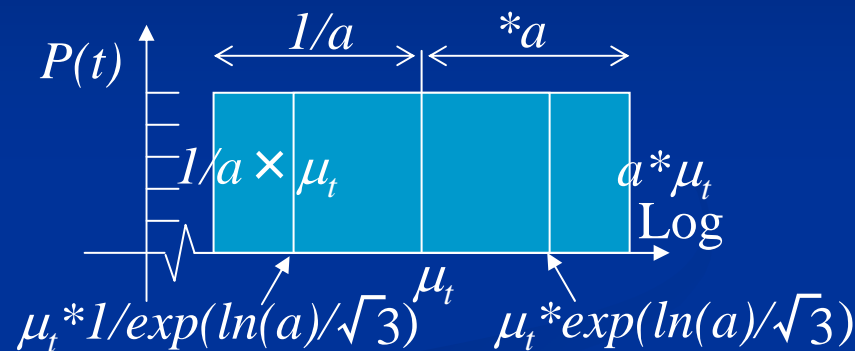
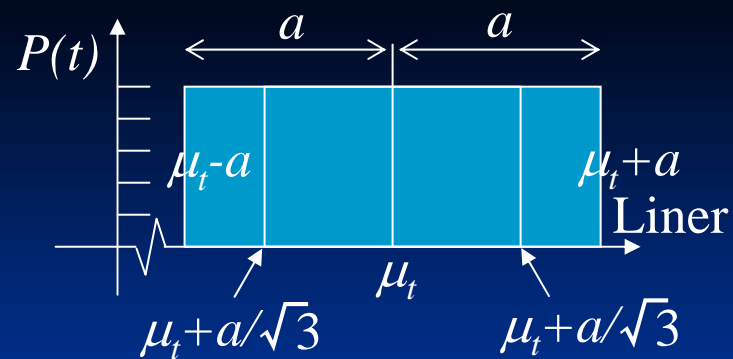

Ratio of activity (Estimated/Actual)

Standard Uncertainties $u(x_i)$ in Activity Estimation of a Segment

Experimental results, $d = 1.0\text{m}$					
Filling rate	Thickness of segment				
	10cm	20cm	30cm	40cm	60cm
0.075	1.20	1.25	1.25	1.54	1.88
0.121	1.17	1.36	1.44	1.71	2.21
0.214	1.14	1.47	1.69	2.29	3.78

Calculated results, Filling rate = 0.214					
d	Thickness of segment				
	10cm	20cm	30cm	40cm	60cm
0.5m	1.52	1.86	2.29	2.83	4.32
1.0m	1.31	1.59	1.96	2.39	3.61
2.0m	1.25	1.50	1.81	2.20	3.23
3.0m	1.22	1.46	1.75	2.11	3.07
4.0m	1.21	1.44	1.72	2.07	3.00

Estimation of Combined Standard Uncertainty in Activity Estimation of a Portion

- The degree of uncertainty in the activity estimation of a portion was estimated by conducting **Monte Carlo simulations**
- Uncertainty larger than the square root of 10 may be impossible to demonstrate whether the specific activities of the portions satisfy the transport requirement.
- The reference value of combined standard uncertainty to be 2 was chosen.

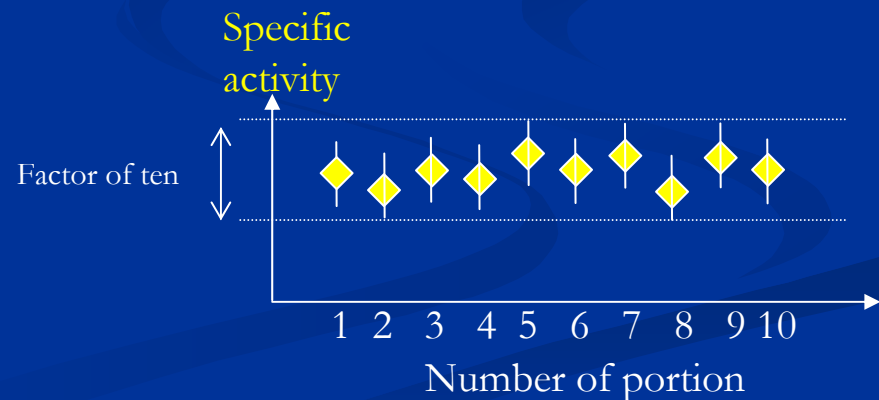
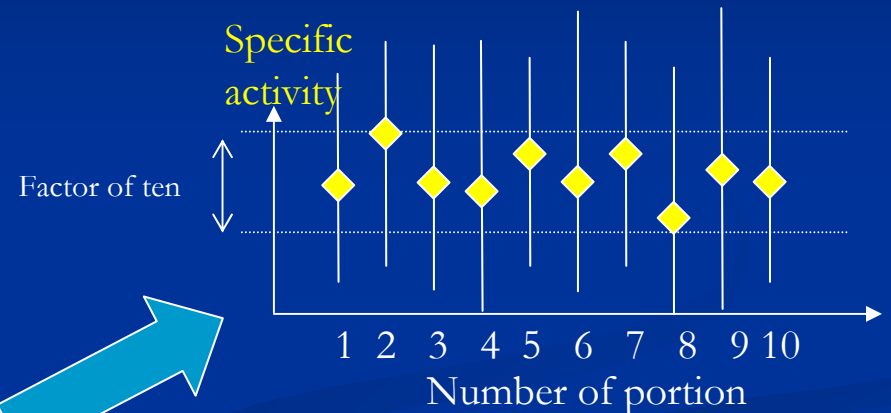

Applicable Scope

- Range where combined standard uncertainty in activity estimation of a portion is **less than 2** as functions of segment thickness, filling rate and the distance between the radiation detector and the surface.
- **d : 3.0m, filling rate:30 %**, the thickness of a segment should be less than **approximately 36 cm**.

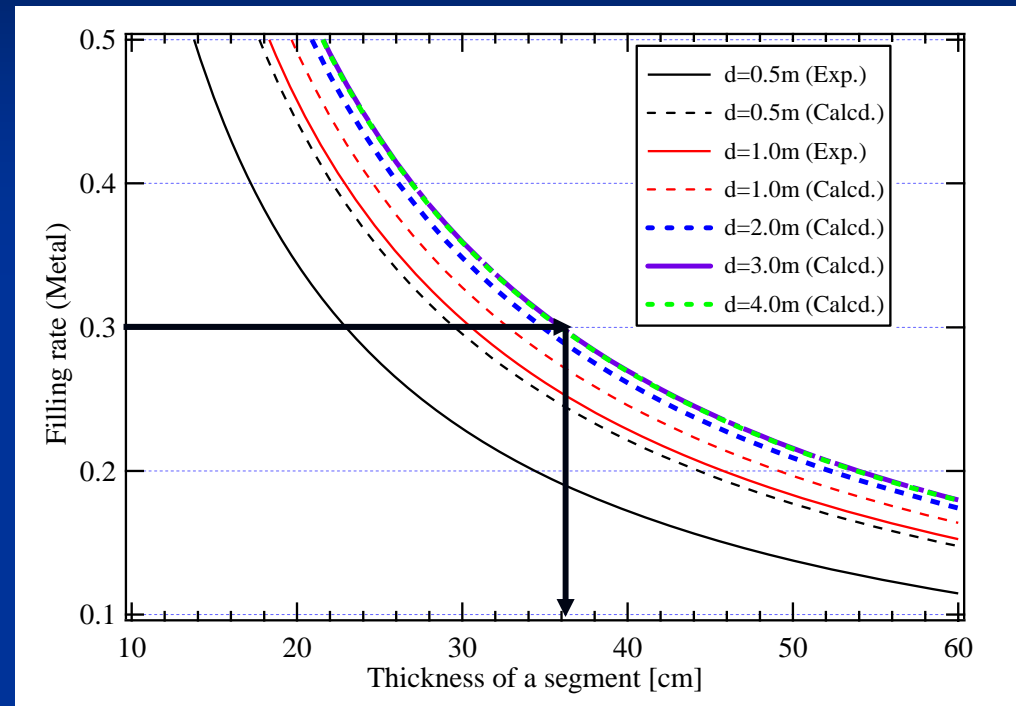

Using these results, rational radioactive transport can be achieved because an appropriate filling rate and segment thickness can be predicted while taking the uncertainties into account.

Conclusions

- A new specific activity distribution estimation method for large items of low-level radioactive waste has been developed by utilizing gamma-ray measurement, mass measurement, shape measurement by photogrammetry and MCNP Monte Carlo calculation techniques.
- The standard uncertainty in the activity estimation of a segment was experimentally obtained and that of a portion was estimated by Monte Carlo simulation by assuming that the probability density of uncertainty in the activity estimation of a segment is a log-uniform distribution.
- Application scope was clarified.

Future Work

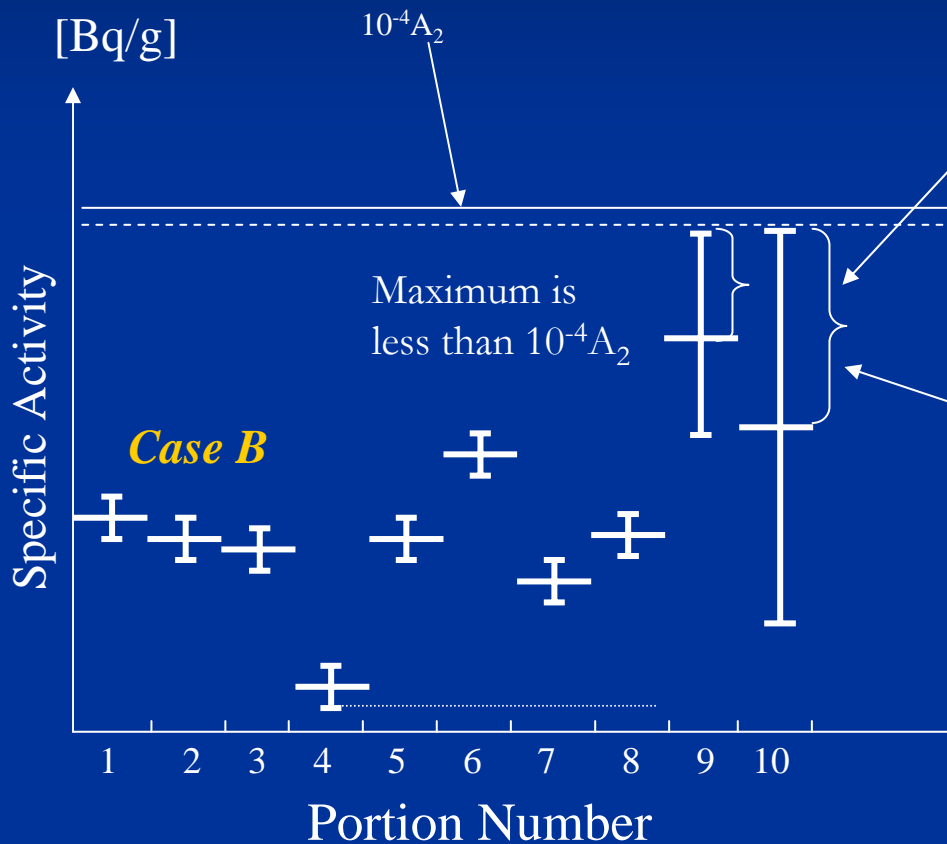

- Larger uncertainty can be acceptable for compliance with the transport requirement (**Case B**) according to the specific activity of a portion.
- Uncertainty with considering BG correction

Thank you for your attention!