

TESTING OF TYPE B PACKAGES IN JAPAN TO CONDITIONS DIFFERENT FROM THE REGULATORY PACKAGES TEST STANDARD

Chihiro Itoh

Central Research Institute of Electric Power
Industry (CRIEPI)

Toshiari Saegusa

Central Research Institute of Electric Power
Industry CRIEPI

Hidetsugu Yamakawa

Central Research Institute of Electric Power
Industry CRIEPI

Koji Shirai

Central Research Institute of Electric Power
Industry CRIEPI

ABSTRACT

A drop test of a spent fuel package with transport frame was performed. The drop height was 7.8m and the target was reinforced concrete floor. Drop tests of spent fuel packages without impact limiters were performed. The drop heights were 1.5, 5.0 and 17m and the target was a reinforced concrete floor. Dynamic crash tests simulating accidental drop of heavy object onto a spent fuel transport/storage package without impact limiters were performed. The heavy object was a slab made of reinforced concrete. The drop heights were 5 to 17m. A thermal test was performed using a spent fuel package specimen. During the thermal test in a furnace, the environmental temperature increased up to 1000 °C. An immersion test under a head of water at 3000 m for one hour was performed. The specimens were packages of spent fuel and high level wastes. In all the cases, the integrity of the specimens was maintained.

INTRODUCTION

The present paper summarizes the tests that have been performed on type B packages by CRIEPI in Japan to conditions different from the Regulatory Test Standard for impact, fire and immersion. The purpose of the testings was to demonstrate the integrity of packages under conditions different from the regulatory packages test standards or simulated real accidents during transport or storage whereas the packages have been designed and fabricated to the Regulations.

MECHANICAL TESTS

Drop test of a package with transport frame¹

A drop test simulating a hypothetical accident of a spent fuel package during handling activity at a harbor was performed.

Specimen package

The specimen package was NFT-32B type package. The specimen was full scale and its internal consisted of a real fuel basket with dummy weights simulating the weight of BWR fuel. Major

specifications of the NFT -32B type packages Type package used for the tests are shown in Table 1. The package is the largest and heaviest among the NFT type packages for BWR spent fuel.

Test conditions

In order to assume a realistic drop accident in this study, various drop/impact accident scenarios along the real transport route of high burn-up spent fuel from the power stations to the reprocessing plant were investigated. Of these scenarios, the scenario of “Package drop onto a loading wharf of a ship port in a horizontal orientation” was selected as the most severe accident. The drop height was 7.8m and the drop target was made of reinforced concrete which simulated a rigidity of the loading wharf, and it was put on the unyielding target.

The test was simulated by computer analysis using LS-DYNA3D, and the analysis was verified by the test. Then, the verified analysis method was used to analyze an accidental drop of another full-scale package (NFT-14P) onto a loading wharf of a ship port. The result was compared with a result of the analysis of the regulatory drop (9-m) test of the NFT-14P type package.

Test results

The containment of the package was maintained after the drop test (Figure 1), and the leak rate was maintained as required. No damage of the basket was observed. This demonstrated that criticality hazard would be prevented assuming insignificant damage to the spent fuel.

Figure 2 shows the calculated time history of stress generated during the drop of the NFT-14P type package. It also shows calculated results of time history of stress generated at the lower part of the package body during a regulatory horizontal 9m drop of the package. The stress generated for the regulatory drop test was larger than that for the realistic drop accident. The maximum stresses are within the design limit and the soundness of the package was maintained in both cases. It was further found that the severity of the regulatory drop test dominates that of the realistic drop accident at the loading wharf at a ship port.



Figure 1. Test of NFT-32B Package Specimen Simulating a Drop Accident at a Loading Wharf of a Ship Port

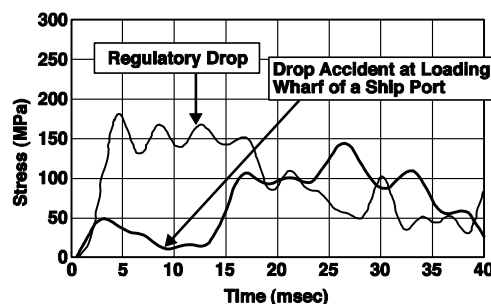

Figure 2. Calculated Results of Time History of Stress Generated at the Lower Part of the Package Body during the Horizontal Drop of NFT-14P Type Cask

Table 1. Major specifications of the NFT type packages used for tests and analyses

Package Type	NFT – 14P	NFT – 32B
Type	Wet and Multi-Layered Cylinder with Lead	Wet and Monolithic Layer Cylinder
No. of Fuel Assemblies per Package	14 PWR	32 BWR
Initial Enrichment	4.2 %	3.7 %
Burn-up (Average)	44 GWD/tU	46 GWD/tU
Cooling Time After Discharge	21 months	35 months
Decay Heat/Package	54 kW	22 kW
Package Length	6.3 m	6.4 m
Package Diameter	2.6 m	2.4 m
Package Maximum Weight	115 t	106 t

Drop tests of package without impact limiters²

When spent fuel packages arrive at their destination, such as storage facility, the impact limiters will be removed from the packages for handling. Drop accidents during handling of the packages without impact limiters were studied.

Specimen packages

The general view of the package used in these drop tests are shown in Figure 3, and the outline of the specifications are shown in Table 2. As shown in Table 2, ductile cast iron packages were selected for the test specimens because they were considered to be candidates from the economical point of view.

Reinforced concrete (RC) slab target used for the drop tests

An RC slab used as a target for the drop tests was designed and manufactured based on a conceptual design of a storage building. The outline of the specifications is shown in Table 3.

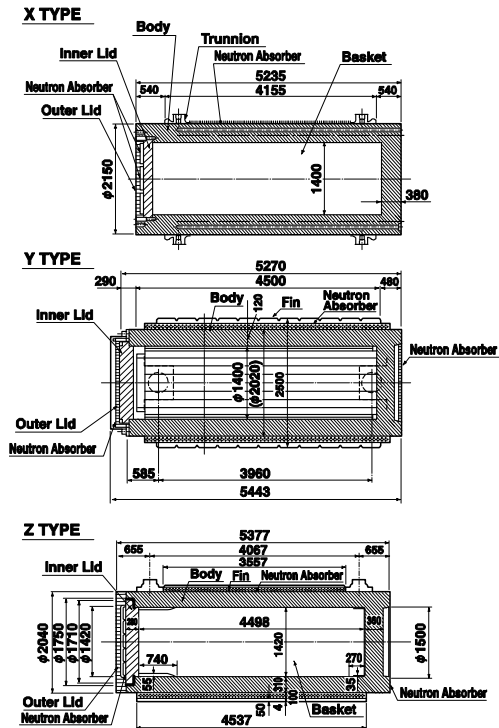

Figure 3. Specimen packages for drop tests without impact limiters

Table 2. Specifications of specimen packages for drop tests without impact limiters

Materials		X-Type Package	Y-Type Package	Z-Type Package
Lid	Inner/Outer Lid	Stainless Steel	Stainless Steel	Stainless Steel
	Lid Bolt	Stainless Steel	Alloy Steel	Alloy Steel
Body	Wall	Ductile Cast Iron	Ductile Cast Iron	Ductile Cast Iron
	Fin	Ductile Cast Iron	Ductile Cast Iron	Rolled Steel
	Trunnion	Stain Steel	Stainless Steel	Stainless Steel
Basket Plate		Borated Stainless Steel Stainless Steel	Borated Stainless Steel	Borated Stainless Steel
Weight (ton)	Inner/Outer Lid	3.5/2.2	4.0/2.2	4.8/2.3
	Body Basket	78.7	79.9	74.7
	Spent Fuel (52 BWR)	13.8	6.0	10.0
		14.6	14.6	14.6
Total		113.9	106.7	106.4

Table 3. Specifications for target RC slab for drop test without impact limiters

Specification	Value		Note
Demension	6m×6m×1.2m : 5 Slabs		For Vertical & Oblique Orientation Drop Test
	6m×8m×1.2m : 2 Slabs		
Concrete Strength	Design Strength	240 kg/cm ²	Standard Curing
	Measured Strength	320 kg/cm ²	
		282 kg/cm ²	
Reinforcing Bar			JIS Class : SD30A
	Designation : D22 · D25		
	Reinforcement Ratio : 1.3%		

Test conditions

The test conditions established are shown in Table 4. The most plausible drop orientations for package drop accident in a storage building will be vertical and oblique in case of failure of a lifting wire. Another possible accident is a drop in the horizontal orientation at the time of unloading from a truck. Accordingly, drop tests were conducted in three different drop orientations, i.e., vertical, horizontal and oblique. Drop heights were determined in accordance with the following considerations:

(1) Normal Operating height

The normal operating height at the time of handling was determined as 1.5 m based on the lifting condition.

(2) Maximum Lifting height

The maximum lifting height in the storage building was determined based on a conceptual design of the building as 7.5 m.

(3) Verification of the Package Safety Margin

To verify a safety margin of the structural integrity of the packages against drop accidents, a critical drop height was determined as 17 m based on a preliminary drop analysis.

Table 4. Conditions for drop tests without impact limiters

Drop Height		Orientation	Package	Note
Normal Operating Height	1.5m	Vertical	X	Verify the package integrity for free drop of the normal operating height
		Horizontal	Z	
		Oblique		Drop test was not conducted, because the strain growth during oblique dropping was sufficiently small as compared with that during vertical and horizontal dropping by prior drop analysis.
Maximum Lifting Height In Storage House	7.5m	Vertical	X	Verify the package integrity for free drop of the maximum lifting height in storage storage house subjected to conceptual design.
		Oblique	Y	
		Horizontal		Drop test was not conducted, because the package was not lifted up to this height in the horizontal orientation.
Verification Of the Package Margin	17.0m	Vertical	X	Verify a margin in the integrity of packages against a drop accident.

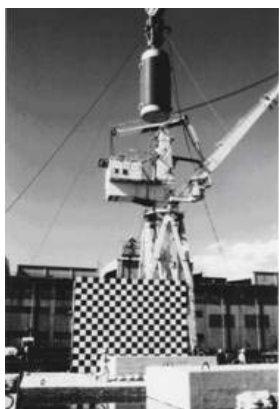

(a) Vertical drop test



(b) Oblique drop test from 17 m height



(c) Horizontal drop test from 5 m height

Figure 4. Drop tests of packages without impact limiters at different orientations

Test Results

Acceleration and strain obtained during the drop tests shown in Figure 6 are depicted graphically in Figure 7. Table 5 shows the results of leak-tightness tests of the packages after the drop tests. The test results obtained are summarized as follows:

- (1) The structural integrity of the packages without impact limiters is maintained against drop accidents at the normal operating height and the maximum lifting height based on the conceptual design of the building.
- (2) According to the results of leak rate measurement, the packages maintained its leak-tightness. Note that it is acceptable to have only one lid tight since both primary and secondary lids should always be in place during handling in the storage facility.
- (3) The assessment of integrity after the drop test at 17 m revealed that the packages had a sufficient margin against the drop accidents during handling in the building.
- (4) There was no damage of the basket, thus the criticality hazard would be prevented assuming insignificant damage to the spent fuel.

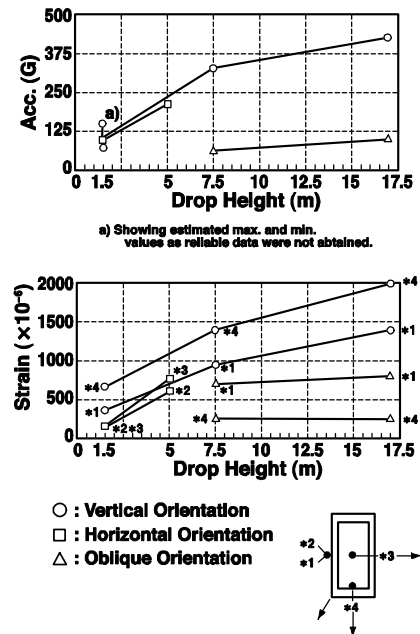

Figure 5. Measurements of acceleration and strain at the drop tests without impact limiters

Table 5. Results of leak rate measurements after the drop tests without impact limiters

Drop test orientation	Drop height (m)	Leak rate (Pa·m ³ /s)		
		Primary lid	Secondary lid	Design limit
Vertical	1.5	5×10^{-7}	3×10^{-9}	1×10^{-6}
	7.5	saturated signal	5×10^{-10}	
	17.0	saturated signal	3×10^{-10}	
Horizontal	1.5	5×10^{-10}	4×10^{-11}	
	5.0	saturated signal	2×10^{-7}	
Oblique	7.5	3×10^{-11}	2×10^{-11}	
	17.0	8×10^{-11}	6×10^{-11}	

Dynamic Crash Tests³

In some countries, spent fuel packages may be stored in buildings and subjected to earthquake. Spent fuel packages are designed to the IAEA transport regulations and are expected to withstand hypothetical building collapse resulting from an earthquake. Dynamic crash tests were conducted to simulate the drop of heavy object onto the package without impact limiters, representing building collapse.

Specimen package

In this test, the X-Type package among the three packages described in Table 2 was employed.

Heavy object – an (RC) slab

Based on a preliminary study, a roof slab of a storage building was selected as the heaviest drop object, which gives the most

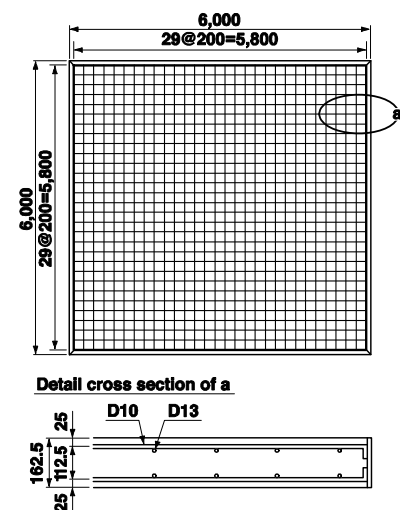

Figure 6. Design of dropping object (RC slab) onto a package without impact limiters

serious effect on the integrity of packages. A horizontal drop was considered as the most likely orientation in a building collapse. The reinforced concrete (RC) slab used in this test was designed and manufactured based on the specifications of the roof slab in a conceptual design of a storage building. The general view of the RC slab used in this drop test is shown in Figure 6, and the outline of its specifications is shown in Table 6.

Test conditions

Drop heights were determined by the following considerations:

1. Lifting height giving no damage to the package sealing boundary

boundary: According to a preliminary analysis for a drop accident from the height of 5 m, there would be no growth of plastic strains in both sealing boundaries between the inner lid and outer lid and the package body, and the sealing function of the package would be maintained in both parts. The drop height was established as 5.0 m that gives no damage to the package sealing boundary.

2. Maximum drop height based on the roof height

A dynamic response analysis was conducted on the aforementioned storage building. The maximum velocity of the roof slab at the time of collapse was calculated by increasing the seismic acceleration hypothetically until the building collapsed. (It is noted, however, the building concerned would not collapse by a limit earthquake for design.) The drop height was determined as 17.1 m by considering this velocity with the roof height of the storage building. According to a package analysis, the drop accident would not cause any plastic strains in the sealing boundary between the inner lid and the package body and the package would maintain the sealing function at the inner lid.

Table 6. Specifications of dropping object (RC slab) onto a package without impact limiters

Specification	Value	
Dimension	6m×6m×162.5mm : 2 Slabs	
Concrete Strength	Design/ Measured Strength	240 / 280 kg/cm ²
Reinforcing	JIS Class : SD30A/ Designation : D10 • D13	
	Reinforcement Ratio : 1.0%	

Test results

Figure7 shows the results of strain in the package specimens without impact limiters. Table 7 shows the results of leak tightness test at the dynamic crash tests. As the results, no leakage from the package lid and no strain larger than the yield strain in the package body were measured by the test. The package would maintain its integrity for the hypothetical building collapse. The test results were simulated by DYNA-3D code to verify the code.

Table 7. Results of leak tightness test at the dynamic crash tests of package without impact limiters

Drop Height	Part	The Leakage Rate (Pa · m ³ /sec)	
		Before Test	After Test
5.0(m)	Inner Lid	Less than 9.1×10 ⁻⁹	Less than 9.9×10 ⁻⁸
	Outer Lid	Less than 2.1×10 ⁻⁹	Less than 1.1×10 ⁻⁹
17.1(m)	Inner Lid	Less than 4.5×10 ⁻⁹	Less than 4.3×10 ⁻⁷
	Outer Lid	Less than 1.6×10 ⁻⁹	5.2×10 ⁻⁸

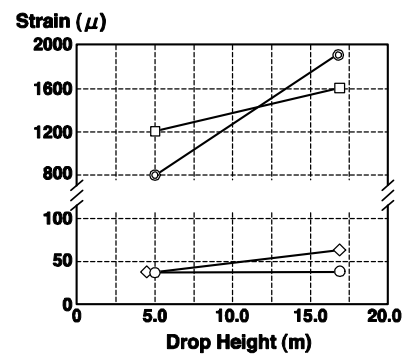

○ : Inner Lid Scaling Boundary
 ⊙ : Outer Lid Scaling Boundary
 □ : Center of Outer Lid
 ◇ : Lower Part of Cask

Figure7. Results of strain measurements of package without impact limiters subjected to dynamic crash tests

HIGH TEMPERATURE TEST⁴

The IAEA transport regulations stipulate a thermal test of 800 °C for 30 minutes. A thermal test at 1000 °C of spent fuel package performed incidentally is reported here.

Specimen package

A wet type specimen package was designed and fabricated to accommodate 27 BWR or 10 PWR spent fuel assemblies as shown in Figure 8. The specifications of the package are as follows:

Weight: about 104 t including 10 PWR assemblies

Outer dimension: 2600 (OD) × 6200 (length) mm

Materials: package body (SUS 304, Pb), fin (Cu coated with Ni), impact limiter (wood covered with steel), neutron shielding (silicon rubber).

Test condition

The fire test was originally designed to maintain a furnace temperature of 800°C, but hydrogen and carbon in the silicon rubber neutron shield burned during the test, causing the average furnace internal temperature be over 1000°C⁰, creating a very severe test environment. The specimen package was taken out of the furnace after 30 minutes, but the silicon rubber continued to burn for 60 minutes.

Test results

Observations after extinction of the fire showed that the silicon rubber had turned out to be white ash and the fin tips were partially melted and lost. The wooden material of the impact limiters was also burned as fire entered from cracks on the outer steel plate that were formed in drop test I. The wood in the impact limiters continued to smolder for five days after the test.

The temperatures of the O-ring component forming the sealing boundary in the fire test and of the lead gamma shielding and the cavity pressure are presented in Table 8. The values obtained in the experiment were smaller than those in the safety analysis for both the maximum allowable material temperature, and the design pressure.

Table 8. Maximum temperature of component and pressure in the package cavity during the test

Component and cavity	Measurement	Design limit
Lead (°C)	205	327
O-ring (°C)	170	230
Cavity internal pressure (MPa)	1.16	6.37

ENHANCED WATER IMMERSION TEST⁵

A water immersion test under a head of water at 3000 m for one hour was performed in addition to the 15 m and 200m immersion tests required by the IAEA transport regulation. The specimens were packaging designed for high level wastes (HLW).

Additionally, internal pressure in the cavity of the packaging was continuously monitored during the immersion test and any leakage of water during the test would have been detected by a water sensor attached inside the cavity of the packaging.

Specimen packages

The specifications and external view of the package for HLW used for the water immersion tests are shown in Figure 9. The package body was made of forged carbon steel that was covered with neutron shielding materials.

The contents of the package (basket, HLW canister, and impact limiters) were removed during the water immersion tests.

Test condition

Immersion test at a head of water of 15 m, 200 m, and 3000m were performed.

Test results

The maximum strain at the package body was within an elastic range and no rupture was observed during the test. On the other hand, the strains and displacements of the lid plate showed nonlinear behavior causing a permanent displacement after unloading. However, the leak rates did not show any differences before and after the immersion test of 3000m water depth. Results are summarized as follows.

- (1) No leakage was detected at any sealing boundary during the immersion test and no reduction in the sealing characteristics was observed by comparison with tests performed before and after the immersion tests;
- (2) The stress intensity of the package at main body was very small for the 200 m test. Most of the package body was within the elastic limit for the water pressure of 3000 m, and the allowable stress intensity of the material did not exceed at any part ;
- (3) Deformation by the water pressure is 1 mm or less for the inside cylinder and 2 mm or less for the cover at 3000 m;
- (4) The shielding tests performed before and after the immersion test indicated that there was no reduction in the shielding performance for gamma rays or neutrons.

It is confirmed by the demonstration tests that the package will retain its integrity against the immersion tests of the IAEA transport regulation with a very large safety margin to the water pressure equivalent to a head of 3000 m.

References

1. Ito, C., Yamakawa, H., Saegusa, T., Demonstration of the safety of spent fuel transport casks under regulatory tests and realistically severe accident, Proceedings of PATRAM 2001, Chicago, USA.
2. Kato, Y., Hattori, S., Ito, C., Ozaki, S. and Kato, O., Storage Cask Drop Test on Reinforced Concrete Slab, Proc. PATRAM 1992, Vol. III, P.1443-1450
3. Kato, Y., Hattori, S., Ito, C., Shirai, K., Ozaki, S. and Kato, O., “Drop Test of Reinforced Concrete Slab onto Storage Cask”, PATRAM’1992, Vol. III, P1451-1458
4. Nagakura, T., Abe, H., Yasuda, M., Esashi, Y., Maki, Y. and Shiomi, S., Demonstration Test of 100 ton Class Spent Fuel Transport Cask, Proc. PATRAM 1986, Vol. I, P.283-291
5. Itoh, C., Gomi, Y. And Kato, O., Immersion test for Cask Transporting Vitrified High-Level Radioactive Waste”, RAMTRANS, Vol.9, No.3, p.209-214 [1998]

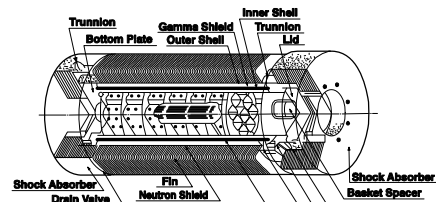

Figure 8. Specimen package for spent fuel used for thermal test

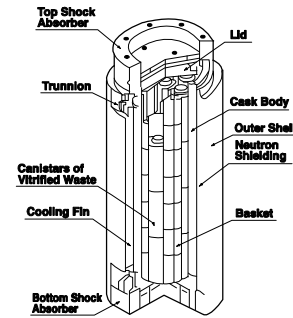

Figure 9. Specimen package of HLW for water immersion test