

CONCEPTION AND PRODUCTION TECHNOLOGY OF DUAL PURPOSE TRANSPORT CASKS WITH ADVANCED SAFETY

Matveev V.Z., Morenko A.I., Shapovalov V.I.

Russian Federal Nuclear Center - All-Russian Research Institute of Experimental Physics
607190, Sarov, 37 Mira Prospect, Russia, tel. (83130) 43306, matveev@vniief.ru

**Maslov A.A., Orlov V.K., Semenov A.G.,
Sergeyev V.M., Uferov O.I., Visik A.M.**

Bochvar Institute of Inorganic Materials (VNIINM)
123060, Moscow, 5-A Rogova street, tel. (499) 190-2425, post@bochvar.ru

ABSTRACT

This poster is given up to concept of a new generation of dual-purpose transport casks (transport and temporary storage) with advanced safety. According to this concept the basic cask, which intended for transportation and temporary storage of spent fuel elements of the VVER-type reactors, there is a capability to produce the dual-purpose packages for spent fuel of all types of the Russian and foreign power reactors. At the expense of minor adaptations of such cask it is possible to execute operations with spent fuel elements having the wide range of burnup and storage period in pool, and also with fuel elements inclusive mixed uranium-plutonium fuel. Due to use of high-strength alloy on a base of depleted uranium for the gamma shield it is possible to create the cask which can be conveyed by railway and motor transport, and in some cases even by air. The siloxane rubber is used for secure fulfillment of all neutron protection requirements. Calculations and experiments have shown that such casks will meet to all IAEA safety requirements in the different operating conditions, accidents and also at probable terrorist effect. The industrial production technology of such casks was developed and tested during manufacturing of the cask model (scale 1:5). The estimation of an economic efficiency of the creation of such casks production on one Russian plant was carried out. It was shown that the investments should be paid back within the first three years.

INTRODUCTION

In Russia and abroad there is an objective necessity for a new generation of casks for transportation, storage and disposal of accumulated spent nuclear fuel reserves and radioactive waste. The containers currently used in Russia and other countries are intended only for transportation. Storage and disposal of the spent nuclear fuel can not be carried into practice with them. The problem can be resolved by creation of the multi-purpose universal containers intended, both for transportation and storage, and for spent fuel and radioactive waste disposal. The basic requirements to such containers are:

- Conformity to the TS-R-1 requirements;
- Maximum safety at operating conditions, accidents and also at probable acts of terrorism;

- Maximum capacity per mass and size unit;
- Minimum overall dimensions per capacity unit adapted to all kinds of transports;
- The specific cost (cost per 1 t of uranium transferred) compared to the specific cost of metal-concrete designs.

Based on the listed requirements the profound study of shielding materials was carried out. The relative mass and dimensional parameters of different shields are shown in fig. 1

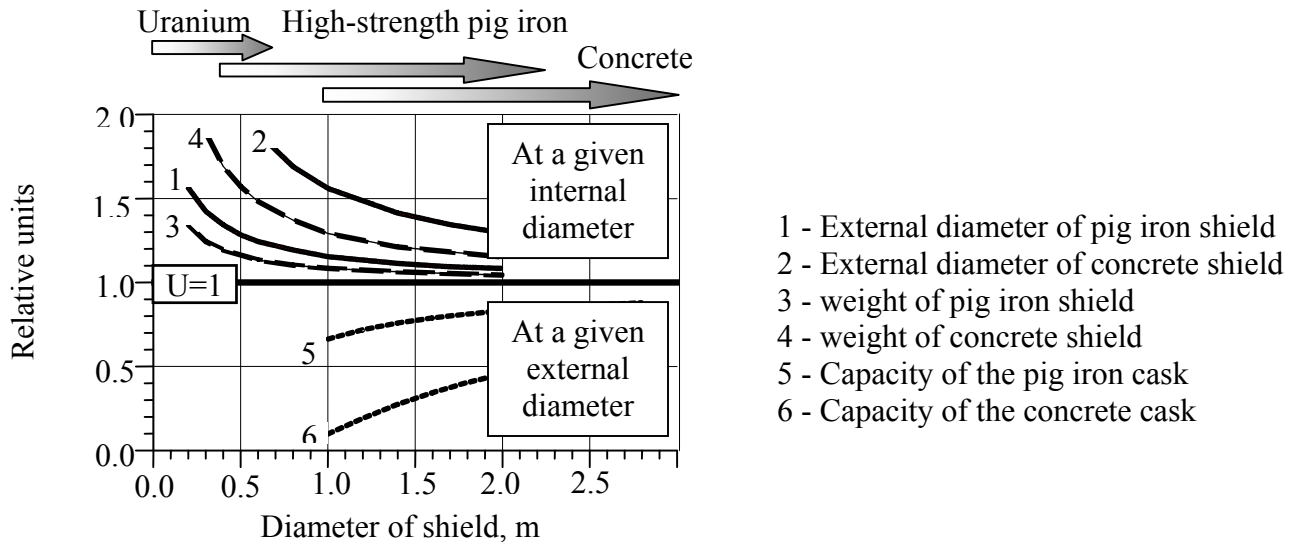

Fig.1. The mass and dimensional parameters

The combination of electronic and nuclear density of uranium and low-alloyed uranium makes these materials the best one for use as a gamma radiation shield for designs of universal containers. On the other hand, the materials of universal containers should provide a maximum design safety not only at operating conditions and accidents, but also at probable acts of terrorism. Therefore the materials used must have a high strength property. The comparative parameters of as-cast biological shield materials are shown in table 1.

Table 1. Parameters of biological shield materials

PARAMETER	MATERIAL		
	High-strength cast iron (HF)	Steel 1020	Uranium alloy
Density, g/cm ³	6.8 – 7.0	7.3 – 7.5	18.3 – 18.5
Ultimate strength σ_B	400 MPa	420 MPa	>800 MPa
Yield strength σ_{02}	380 MPa	240 MPa	600 MPa
Percentage elongation δ	< 5 %	18 %	6 %
Impact strength	10 J/cm ²	18 J/cm ²	50 J/cm ²
Fracture	Brittle fracture at -40°C	Brittle at -20°C	Tough fracture at - 40°C

The mechanical characteristics of uranium alloys in the best way meet the requirements for structural materials of biological shield. The concept of a dual-purpose universal transport cask with advanced safety was proposed for spent nuclear fuel transportation and storage. This concept combines both the ideas of depleted uranium effective utilization and depleted uranium use as structural and shielding material. Meeting of all TS-R-1 safety requirements as well as advanced cask stability at accidents and terrorist attacks are provided due to metallic depleted

uranium utilization. For Russian Agency for Atomic Energy (ROSATOM) accumulating huge quantity of depleted uranium (processed waste of the uranium productions) the development of a new generation casks on a base of metallic depleted uranium is the most rational and perspective way. It allows solving a problem of the accumulated depleted uranium stockpiles utilization rather effectively because now they do not find any application and thus create an ecological hazard to an environment. The similar technical policy concerning a new generation of casks for spent nuclear fuel is being performed now in USA with regard to not smaller uranium stockpiles. These stockpiles were created as a result of production of fissile materials in frames of military programs. In DOE there is a program, valid up to 2010, on creation of multi-purpose containers on a base of depleted uranium for spent nuclear fuel storage, transportation and disposal, because depleted uranium provides the most effective gamma shield and maximum safety.

A NEW GENERATION CONTAINERS ON A BASE OF DEPLETED URANIUM

R&D activities to create new generation dual purpose containers on a base of depleted uranium intended for spent nuclear fuel transportation and storage were started by our institutes at the beginning of the 90-th and are going on till the present time. As a result of such activities the large amount of computational, theoretical, exploratory and technological investigations were carried out. As a result:

- As-cast uranium alloys, in particular the special uranium alloy BZ-2 was developed. The properties of this alloy under different operating conditions of the gamma-shielding unit were investigated. The efficiency of BZ-2 under such conditions within 50 years was demonstrated. The small containers with uranium alloys designed were already used for transportation, storage and management of high-level radioactive materials in an industry, science and medical engineering. The subsequent technological investigations allow us to recommend the uranium alloys designed not only for small shield at transportation and management of high-level radioactive materials but also as a material for multiton radioactive shield of transport casks;
- New know-how of gamma shield units manufacturing was developed and tested in a production scale. We have applied the process of uranium alloy casting directly into a leakproof ring jacket mould. Further rings were connected by argon-arc welding in the single unit being simultaneously a structural load-bearing element [1]. For prevent an interaction between stainless steel and uranium the especial coating was developed. It protects steel reliably up to temperature of 1400°C;
- The engineering design of a dual-purpose package TUK-117, intended for transportation and storage of VVER-1000 spent nuclear fuel assemblies (capacity - 36 assemblies) was developed. In accordance to the requirements of national and international Regulations the computational and theoretical substantiation of safety was made. Besides, the safety of package at accidents and acts of terrorism on nuclear power plants, storage sites and processing plants was computed;
- The preliminary design of dual-purpose package, intended for transportation and storage of 540 spent spark elements of plutonium production uranium-graphite ADE-type reactors was developed, and the preliminary computational and theoretical investigations of its different safety aspects were carried out.

Dual-Purpose TUK-117

The engineering design of dual-purpose package TUK-117 [2] that is intended for temporary storage and transportation of VVER-1000 36 spent nuclear fuel assemblies involves the manufacturing of multiton radiation uranium shield using the know-how described above. Mass and overall dimensions of TUK-117 provide realization of indispensable operations with the container and basket inside nuclear power plant, container depot and stationary spent nuclear fuel

assemblies depot. They also allow transportation of the container in a horizontal state on special goods-carriage, made pursuant to Russian Standard 02-BM. Besides the TUK-117 design provides a possibility of transportation by a water transport and enables the local displacement by auto-car transport on special trailers. TUK-117 consist of: the shielding container 1 – strong cylindrical leakproof shell (vessel) and basket 2, which is set inside of the shielding container and serves for the ordered disposition of the 36 VVER-1000 spent nuclear fuel assemblies. General view of a TUK-117 is shown in a fig. 2.

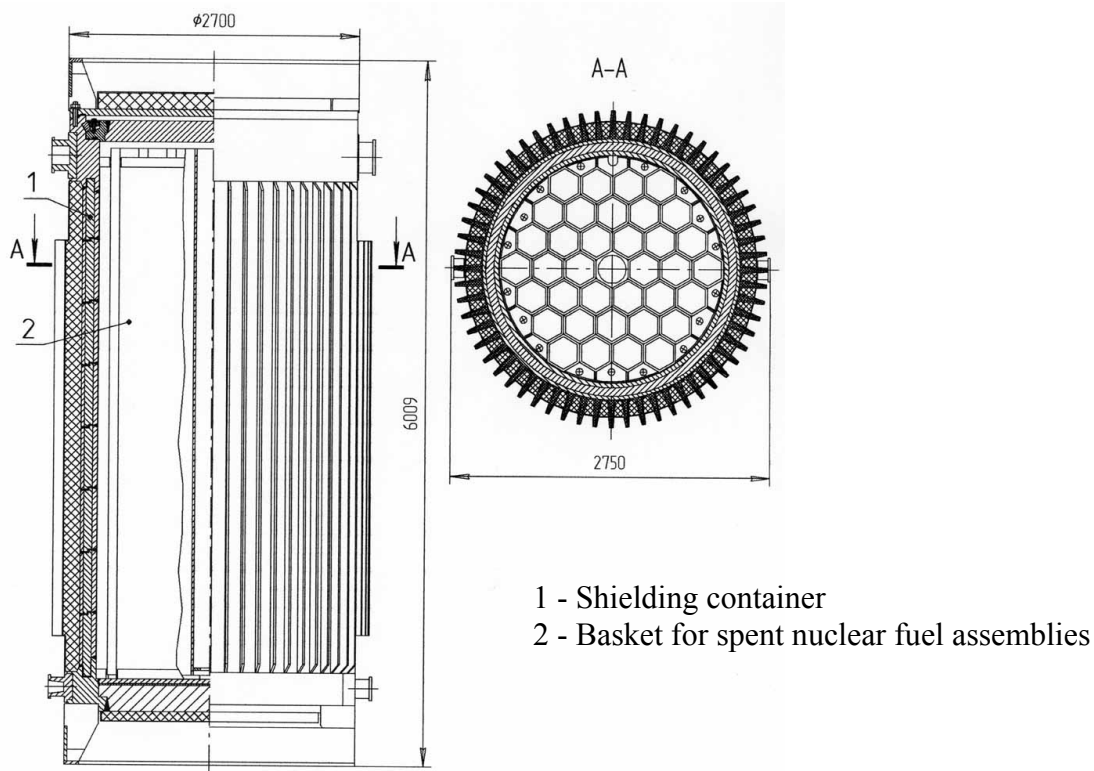

Fig. 2. General view of TUK-117

Main parameters of TPCS-117 are:

- Capacity - 36 VVER-1000 spent nuclear fuel assemblies,
- Mass of empty package, not more than 102.5 t,
- Mass of loaded package, not more than 144.5 t,
- Effective life, not less than 50 years.

The shielding container of TUK-117 consists of body and two pressure sealing covers. The body of shielding container looks like a multilayer cylindrical sleeve consisting of:

- Internal power shell,
- Lateral uranium gamma-shield,
- External power shell,
- Lateral neutron shield,
- Bottom with the neutron shield and lower shock absorber,
- Heat-output ribs with outside facing (lateral shock absorber),
- Two top lifting eyes for a container lifting,
- Two lower lifting eyes for overturning of container in a horizontal state.

The internal and external power shells are made of a stainless steel 12Cr18Ni10Ti. The thickness of the internal power shell is 40 mm; thickness of the external shell is 30 mm. The lateral gamma shield is made of BZ-2 alloy on a base of depleted uranium and its thickness is 72

mm. Internal power shell, lateral uranium gamma shield and external power shell form a three-layer cylindrical shell, which is the basic supporting element (Biological gamma shielding unit) of a container design. This unit is collected of 8 ring elements. Leakproof welds weld rings with each other. The bottom is welded to the lower face end of unit. 60 longitudinal heat-output ribs having a U-profile and manufactured of a sheet stainless steel 15 mm in thickness are welded on Biological gamma shielding unit outside surface. These ribs act as a lateral shock absorber side by side with a function of the heat-output. 60 facings made of 5-mm sheets of stainless steel have a leakproof weld with heat-output ribs. The fragment of heat-output ribs, outside facings and lateral neutron shield is shown in fig. 3. The space between ribs and facings is filled with siloxane rubber and forms the lateral neutron shield 140-mm in thickness. Top and bottom neutron shield and shock absorbers are set on an external side of covers.

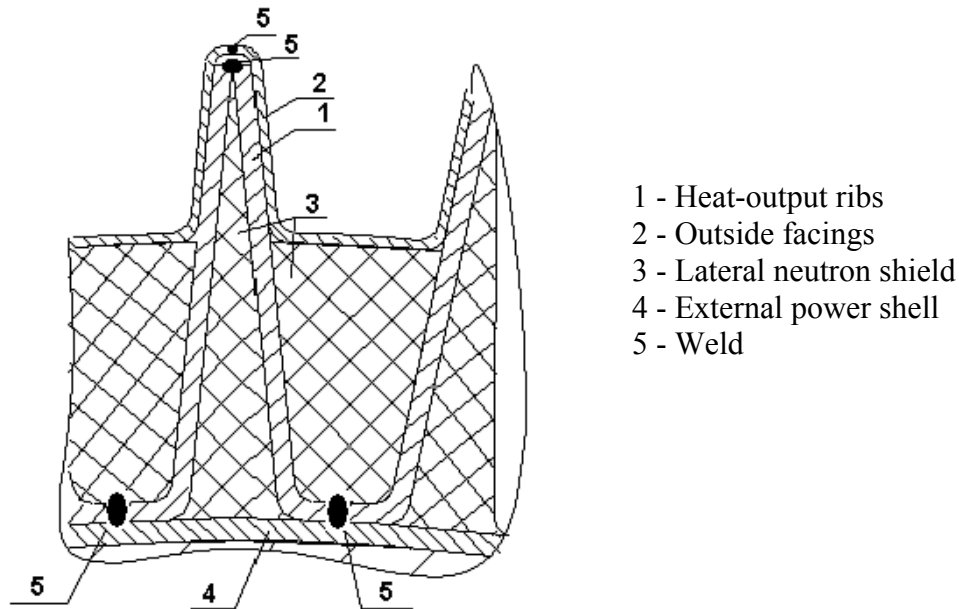

- 1 - Heat-output ribs
- 2 - Outside facings
- 3 - Lateral neutron shield
- 4 - External power shell
- 5 - Weld

Fig. 3. Fragment of heat-output ribs, outside facings and lateral neutron shield

The general view of the basket used in TUK-117 for ordered disposition of 36 VVER-1000 spent nuclear fuel assemblies is shown in a fig. 4.

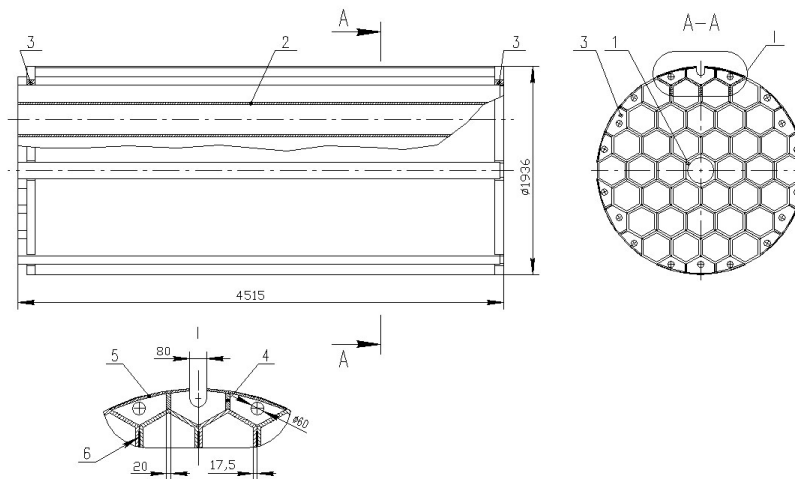

Fig.4. General view of a basket

The basket used in TUK-117 represents a welded construction consisting of following main elements:

- Central hexahedral tube for its holding during the process of installation into the container, taking out from the container and local displacement outside of the container (position 1 in fig. 4);
- 36 technological hexahedral tubes for the spent assemblies installation (position 2 in fig. 4);
- 6 lower and 6 upper support segments (position 3 in fig. 4);
- 12 heat-output ribs (position 4 in fig. 4);
- 18 heat-output facings (position 5 in fig. 4).

The structural members of a basket are manufactured of aluminum alloy AMG-6 (Aluminum alloy with ~6 wt % Mg), having the low density, high physical, mechanical, thermal and processing properties, and also improved corrosion resistance in aggressive acid-alkaline medium. The boron plates for neutron absorption (position 6 in fig. 4) were included in a basket structure also. The large capacity basket designed for TUK-117 differs by a design simplicity and technology. It has no analogy in domestic and foreign container building.

Gamma shield unit is made as a three-layer (steel – uranium-steel) cylindrical shell made up of 8 elemental rings in a height. Pressure-tight welds on internal and external shells connect rings with each other. Cycle of ring element manufacturing includes the following operations:

- Manufacturing and preparation of the jacket mould;
- Melting and casting of uranium alloy BZ-2 into the prepared jacket mould;
- Machining of the open face end;
- Leakproof welding of the finished face end (argon-arc welding);
- Machining of the ring element up to the final sizes.

In a fig. 5 the model of the gamma shield unit (scale 1:10), welded of 4 rings is shown. All technological operations were optimized during this manufacturing process.

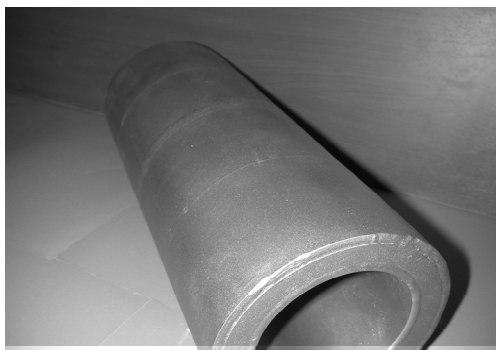

Fig. 5. Model of the gamma shield unit (1:10)

The results of the technological researches have shown a capability and expediency of combination of a casting uranium rings process with casing in a stainless steel shell (12Cr18Ni10Ti). Jacket mould represents the welded construction consisting of a bottom and two coaxial shells, which are welded to it (all made of 12Cr18Ni10Ti stainless steel). Steel sheets are bended and subsequent argon-arc weld makes the shells. The protective coating on a base of phosphate is sprayed on the internal surface of the jacket mould for preventing of interaction of molten uranium alloy BZ-2 and stainless steel. Before coating the internal surfaces of the foundry form are treated by sandblasting to increase an adhesion between coating and stainless steel. Melting and casting of uranium alloy BZ-2 are carried out in an industrial vacuum induction furnace equipped for obtaining of gamma shield unit ring-type elements. Uranium

alloyed materials used for preparation of BZ-2 are selected of the waste and defective goods taking into account the content of alloyed elements and specification of BZ-2.

Dual-Purpose Package for Transportation and Storage of Spent Spark Elements

Dual-purpose package for transportation and storage of spent spark elements of plutonium production uranium-graphite ADE-type reactors consist of the shielding container and internal space for disposition of spent fuel (fig. 6).

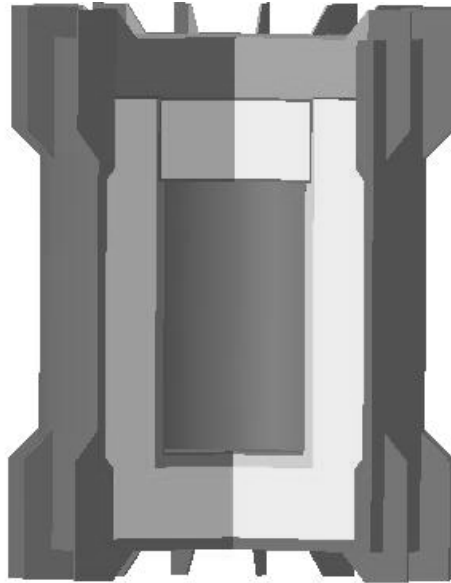

Fig.6. The design-layout scheme of dual-purpose package for transportation and storage of spent spark elements

The development of this package was stipulated the necessity to export the spent spark elements accumulated stockpiles to enterprise “MAYAK” for reprocessing. Now there is no suitable container for SSE transportation. Using technical and technological decisions tested at development of TUK-117 the preliminary design of dual-purpose package on a base of depleted uranium intended for transportation and disposal of spent spark elements was made. Design were developed for loading of 540 elements.

Basic parameters of package for 540 elements are:

- Mass of empty package, not more than 6.2 t;
- Mass of loaded package, not more than 6.5 t;
- External diameter - 930 mm;
- External size with shock absorbers - 1030 mm;
- Height - 1360 mm;
- Height with shock absorbers - 1460 mm;
- Internal diameter - 690 mm;
- Height of internal space - 1035 mm.

Designs of dual-purpose containers provide a capability of transportation by railway, water transport and enable transportation by motor transport on especial trailers. The results of computational investigations confirm the design’s meeting to national and IAEA safety requirements at normal operating conditions and accidents. Package retains stability at probable terrorist acts also.

ECONOMICAL PARAMETERS

The estimation of efficiency of the investments in production of new generation containers was made for one of the Russian firms. An overall costs of the project – 3.4 million. USD. A volume and directions of the demanded investments:

- Development and improvement of engineering designs - 570 thousand. USD,
- Modernization and advancing of production - 545 thousand. USD,
- Manufacturing of prototypes and interdepartmental tests for conformity to the IAEA safety requirements - 1 million. 100 thousand. USD.
- Updating of design documentation, manufacturing of first serial units, tests - 1 million. 70 thousand. USD.
- Final correction of documentation and transfer it to series production -115 thousand. USD.

The financial parameters are given in tab. 2.

Table 4. Financial parameters

Parameter	The forecast in view of the investments		
	1 st year	2 nd year	3 rd year
Volume of implementation	2	10	10
Profit	400 000 USD	2 000 000 USD	2 000 000 USD

CONCLUSIONS

1. Usage of metallic depleted uranium has ensured creation of dual-purpose packages with a maximum load of spent fuel.
2. The dual-purpose transport packages with depleted uranium gamma shield completely meet up-to-date national and IAEA safety requirements and provide defense against terrorist acts. The warranty service life of such containers exceeds 50 years.
3. The greatest effect of metallic uranium use is supposed to be attained with the design of small-sized casks.

REFERENCES

1. The patent of Russian Federation №2089341, cl. B22D19/10, publ. 06.12.1994..
2. Proceedings of the International conference on safety of nuclear materials transport, IAEA, Vienna of July 7-11, 2003.