

**Proceedings of the 15th International Symposium on the  
Packaging and Transportation of Radioactive Materials  
PATRAM 2007  
October 21-26, 2007, Miami, Florida, USA**

**Predicting the Response of the Impact Limiter in the HI-STAR Family of  
Transport Packages Using a Benchmarked LS-DYNA Dynamic Model**

Kris P. Singh, John (Xuejun) Zhai, Alan I. Soler  
Holtec International, 555 Lincoln Drive West, Marlton, NJ 08053, U.S.A.

**ABSTRACT**

HI-STAR spent fuel transport casks are protected by AL-STAR impact limiters against excessive impact loads under the hypothetical 9-m drop condition postulated in 10CFR71. The aluminum honeycomb is used as the energy-absorbing material in the AL-STAR impact limiter, which was evaluated in a series of 1/4-scale 9-m drop tests conducted at the Oak Ridge National Laboratories (ORNL) in the late 1990s to demonstrate regulatory compliance of the HI-STAR 100 package design. The test data was recently used to provide the data points for the LS-DYNA benchmarking analyses reported in this paper. The LS-DYNA model based on the actual configuration of the 1/4-scale test model is used to simulate the one unsuccessful and four successful tests documented in the HI-STAR 100 1/4-scale test report. Results predicted by LS-DYNA show an excellent agreement with the scale model test data in respect to all key metrics, namely, maximum deceleration, extent of crush, duration of impact, and overall profile of the deceleration curve. The failure of the impact limiter attachment bolts, observed in the initial side drop test, is also correctly predicted by LS-DYNA. The LS-DYNA benchmarking analysis indicates that the structural response of an aluminum honeycomb impact limiter and preloaded bolt joints under the hypothetical drop condition can be accurately predicted through a finite element (FE) analysis.

**KEYWORDS**

Impact Limiter, LS-DYNA, Benchmarking, HI-STAR, Aluminum Honeycomb

**INTRODUCTION**

The structural integrity of a spent fuel transport cask package under accident conditions is normally evaluated through 9-m drop tests as specified in 10CFR71 [1]. In the late 1990s, Holtec International conducted a series of 1/4-scale 9-m drop tests at ORNL to demonstrate that the AL-STAR impact limiter can effectively protect a loaded HI-STAR 100 subject to hypothetical drop accidents as a part of the company's HI-STAR 100 licensing effort (Docket No. 71-9261).

With the advances in computer hardware and FE software, the drop tests conducted 10 years ago can now be effectively simulated by commercially available FE codes, such as LS-DYNA

[2]. The “Evaluation by Analysis” approach using analysis computer codes, as an alternative to a physical test, has been recognized by the USNRC in its Interim Staff Guidance [3]. The objective of this paper is to summarize the results of the simulation of the ¼-scale model tests on LS-DYNA to determine whether LS-DYNA is a reliable prognostic tool for characterizing the impact response of the HI-STAR series of casks. All of the casks use anatomically identical aluminum honeycomb base impact limiters, referred to as AL-STAR. The scale model tests were originally carried out in the 1997-98 time frame in support of the transport certification of the first HI-STAR package, labeled HI-STAR 100 [5].

Guided by the initial series of tests, the company developed the AL-STAR impact limiter for HI-STAR 100 with the following distinguishing features: (i) A snugly fitting skirt around the machined forgings to provide lateral stability during drop events; (ii) A rigid “backbone” connected to the skirt to serve as the mounting surface for the crush material (aluminum honeycomb), which is insensitive to temperature and humidity, and is resistant to fire; (iii) The rigid “backbone” core allows the deformation profile of the crush material to be well defined during drop events.

The drop test program is well documented in a Holtec report [4], which provides the principal source of information for the benchmark effort. The impact limiter tests were not all successful; failure of fasteners joining the bottom impact limiter to the cask in the first of two “side drop” tests forced a redesign of the attachment system. This failure, while disappointing at the time, provides valuable information for this study, because the mark of a valuable simulation tool is its ability not only to predict success, but also its ability to predict failure. Because the impact limiters used in all HI-STAR packages are of the same genre as the ones simulated in the ¼-scale tests in respect of all design features that typify their shock absorption behavior, the benchmarking of LS-DYNA on these scale model tests provides a sound technical basis for utilizing this code and analysis methodology to analyze all AL-STAR impact limiter models that have been developed by Holtec to equip subsequent HI-STAR models (Models HB, 180, and HB).

The accelerometer and high-speed photography data collected from the scale model test provide the means to benchmark the LS-DYNA prediction model with respect to (i) the peak deceleration, (ii) the maximum crush, and (iii) the duration of crush. In addition to these three quantitative benchmarks, two qualitative benchmarks can be applied, namely: (iv) the contour and size of the crushed impact limiter surface, and (v) the shape of the accelerogram. Of the above, the shape of the accelerogram is a less definitive benchmark indicator because the filtering of the raw deceleration data, necessary to remove high frequency noises, also affects the fidelity of the deceleration time-history curve. Nevertheless, the overall shape of the deceleration curve, particularly the profile of its peak, is a valuable benchmarking tool.

The above five benchmark parameters provide a comprehensive basis for assessing the competence of the LS-DYNA model. However, it is important to bear in mind the intrinsic limitations of the scale model with respect to certain important aspects of the package’s performance. Specifically, the potential of leakage from a gasketed joint, a decidedly key design interest, cannot be inferred from any scale model tests, the HI-STAR 100 package scale model tests being no exception. Indeed, recognizing the futility of seeking a reliable answer to the question of post-crash bolted joint integrity, the USNRC consented to building

the HI-STAR 100 scale model without a gasketed joint (the gasketed joint integrity under the drop events was analyzed separately using a classical plate-and-shell theory formulation in the HI-STAR 100 SAR [5]). However, the HS-DYNA simulation of the performance of the bolted connection between the cask and the impact limiter in both successful and unsuccessful tests allows this benchmarking study to demonstrate whether LS-DYNA can predict failure of bolted fasteners.

## **SCALE MODEL DROP TESTS**

The tested HI-STAR 100 cask scale model consists of two thick walled steel cylinders that represent the overpack and the MPC, respectively. The model was properly scaled down to be  $1/4^{\text{th}}$  the dimension, and  $1/64^{\text{th}}$  the weight of the HI-STAR 100 cask. Other inertia properties of the “rigid” cask were also proportionally preserved as demonstrated in [6]. The AL-STAR impact limiter was also volumetrically scaled down in the manner of the cask. Thus, the length (axial dimension), skirt diameter and O.D. of the AL-STAR scale model, as well as the thickness of backbone members, were made equal to  $1/4$  of those dimensions of the full-size impact limiter. The fasteners utilized to attach the impact limiters were reduced in size by using a scaled diameter in the unthreaded region.

Four drop orientations were considered in the  $1/4$ -scale HI-STAR 100 drop tests, namely, top end drop, CGOC drop (bottom impact limiter impacts ground), side drop, and slapdown drop (top impact limiter impacts ground first). Among them, only the side drop and slapdown drop involve participation by both impact limiters. Dummy impact limiters with equivalent mass and mass moment of inertia properties were used in the end and CGOC drop tests.

A total of five 9-m drop tests were performed at the ORNL from December of 1997 through February of 1998 using the  $1/4$ -scale HI-STAR 100 package per [4]. The top end and CGOC drop tests were performed first with satisfactory results. After each drop event, the impact limiter remained attached to the cask and no bolts were found to be broken. Filtered decelerations were also less than  $240g$ 's. However, the subsequent side drop test failed all 8 bottom impact limiter attachment bolts in shear, although the peak deceleration was acceptable. Because of the unsuccessful side drop test, the bottom impact limiter-to-overpack attachment design was modified to incorporate the following changes: (i) the number of attachment bolts was increased from 8 to 16, (ii) the size of attachment bolts was increased to more closely match  $1/4$  of the full-size attachment bolts, (iii) the attachment bolt material was changed from SA193-B7 to SA193-B8S, the same material of the top impact limiter attachment bolts, (iv) eight alignment pins between the cask bottom and bottom impact limiter end plate were added to increase the shear capacity of the impact limiter to cask connection. Following the design modification, the slapdown and the second side drop tests were performed successfully with no bolt joint failure. The earlier successful top end and CGOC drop tests were deemed valid and therefore not repeated subsequent to the design changes.

## **LS-DYNA NUMERICAL SIMULATION**

Two LS-DYNA FE models are developed to simulate the  $1/4$ -scale HI-STAR 100 package drop tests. The first model is used to simulate the end, CGOC and the first side drop tests, and the second one is used to simulate the slapdown and second side drop tests performed after

the design modification on the bolt connection between the bottom impact limiter and the cask. The two LS-DYNA models are constructed according to the dimensions specified in design drawings of the 1/4-scale test model. Because of symmetry of the drop event, only a half model is needed for the analysis.

The HI-STAR 100 package half model developed for simulating the first three tests consists of 50,604 nodes and 74,692 elements. The model developed for the slapdown and second side drop tests consists of 62,198 nodes and 87,111 elements. Shell elements are used to model the thin impact limiter members, such as radial gussets and enclosure skin. The overpack, MPC, impact limiter honeycomb blocks, and other thick backbone components are modeled using solid elements. The impact limiter end plate that directly touches the cask end is modeled by thick shell elements. Note that the impact target, i.e., a 12' thick reinforced concrete pad with a 6" thick armored steel plate surface [4], is modeled by rigid solid elements.

Figure 1 shows the LS-DYNA model for the slapdown drop test. To achieve proper balance between accuracy and efficiency, the FE grid sizes of the MPC model and the majority of the overpack model are relatively coarse while the top end of the overpack, which is connected to the rest of the overpack model through a tied contact command in LS-DYNA, is meshed with fine grids due to the radial bolt joints with the top impact limiter. The impact limiter attachments bolts are modeled in detail with sufficiently fine grids as shown in Figure 2 so that the LS-DYNA model can not only predict the bolt connection failure for the initial side drop test but can also demonstrate the structural integrity of bolt connection in other four successful drop tests. Based on the exact locations of the working accelerometers attached to the 1/4-scale HI-STAR 100 test model, deceleration results are extracted at the corresponding nodal points on the LS-DYNA model for comparison with the measured data from the drop tests.

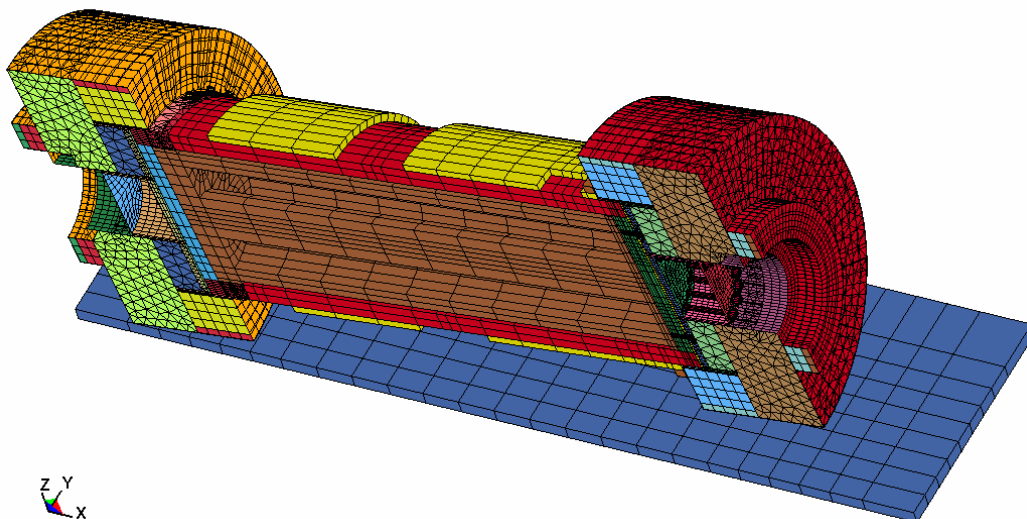

Figure 1: LS-DYNA Model of the 1/4-Scale HI-STAR 100 Slapdown Drop Test

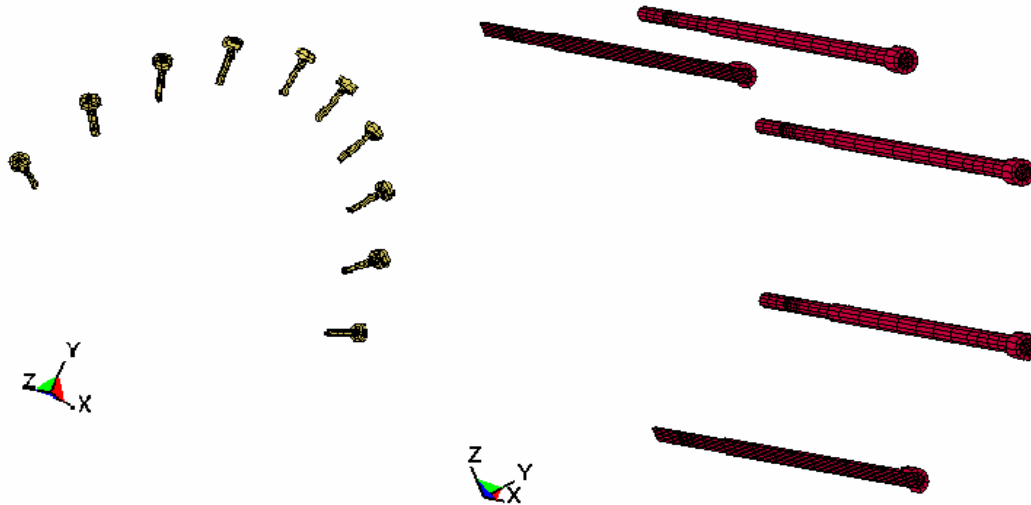

Figure 2: LS-DYNA Model of Impact Limiter Attachment Bolts

The AL-STAR impact limiter of the HI-STAR 100 package consists of a steel backbone structure, five types of aluminum honeycomb blocks and a thin stainless skin. The two impact limiters attached to the ends of HI-STAR 100 are essentially identical except for the attachment bolt connection with cask. To capture the interaction between impact limiter steel components and aluminum honeycomb blocks and that between impact limiters and the ground, the impact limiter is modeled in great detail following the exact configuration and dimensions of the scale test model. Finally, the behavior of impact limiter aluminum honeycomb blocks is characterized by the LS-DYNA material model type 26 (MAT\_HONEYCOMB) based on the material properties documented in [4] and [7]. The LS-DYNA honeycomb material model was developed with a built-in strain rate effect.

LS-DYNA assumes material models that relate true stress to true strain. Therefore, true stress-strain relations of the aluminum honeycomb blocks are established based on the engineering stress-strain properties. Because of the honeycomb configuration, which is modeled with solid elements in LS-DYNA, the nominal cross-sectional area of the honeycomb block remains essentially unchanged under compressive load. Therefore, the true stress of the aluminum honeycomb block is considered to be same as the engineering stress under the compressive loading condition. The true strain ( $\epsilon_t$ ) of the aluminum honeycomb under compressive load can be calculated from the engineering strain ( $\epsilon_e$ ) using the following relationship [6]:

$$\epsilon_t = -\ln(1 - \epsilon_e)$$

Similarly, true stress-strain curves of the steel materials are used in conjunction with the appropriate strain rate factors to characterize the steel members (including the impact limiter attachment bolts) of the 1/4-scale HI-STAR100 package LS-DYNA model in all drop test simulations.

The top impact limiter is attached to the cask using 20 radial bolts, and the bottom impact limiter is attached to the cask using 8 or 16 axial bolts. All impact limiter attachment bolts are

explicitly modeled using solid elements with the bolt cross-sectional area equal to the effective stress area of the threaded section of the bolt. In addition, all attachment bolts are properly preloaded to reflect the initial stress condition in the bolt prior to the drop test. The initial tensile stress of the impact limiter attachment bolt due to preloading is determined based on the actual torque applied to the attachment bolt (documented in Table 5.1 [4]) and an appropriate torque factor. Preloading of impact limiter attachment bolts is realized in LS-DYNA by specifying an initial stress to the bolt cross-section during the dynamic relaxation phase prior to the transient impact simulation of each drop test.

## BENCHMARKING RESULTS

The LS-DYNA simulation of the ¼-scale HI-STAR 100 drop tests can predict the transient response of each structural component involved in the cask drop, including all measured test results. The measured test results reported in [4] include the three most important quantitative benchmarks discussed earlier in the introduction, namely, the peak impact deceleration of the cask, the impact duration, and the total crush depth of impact limiter. For the five 9-m drop events involving a ¼-scale HI-STAR 100 package, quantitative results obtained from the ¼-scale drop test and from those predicted by the corresponding LS-DYNA analyses are listed in Table 1. The results summarized in the table consistently demonstrate that the LS-DYNA model developed for the benchmarking study accurately predicts the consequence of an HI-STAR 100 package drop accident characterized by the three quantitative results.

**Table 1: Comparison of Test Results and LS-DYNA Simulation Results**

Drop Case		Deceleration <sup>(1)</sup> (g's)		Crush Depth (in)		Impact Duration (ms)	
		Measured	Predicted	Measured	Predicted	Measured	Predicted
1. End Drop		215.74	228.43	2.47	2.49	10.5	10.6
2. C.G. Over Corner		155	150.41	4.19	4.44	15.5	15
3. Side Drop-1 <sup>(2)</sup>		< 240	213.3	N/A	N/A	N/A	11.0
4. Slap-Down	Primary	196	200.5	2.675	2.65	11	10.6
	Secondary	236	249.9	2.86	2.67	10.3	10.1
5. Side Drop-2		182.6	197.7	2.75	2.783	11.8	11.8

Notes: (1) Averaged value of working accelerometers; (2) Failed drop test.

The shape of the predicted deceleration time history also matches the corresponding accelerogram obtained from the test reasonably well. This is clearly demonstrated in Figure 3, where selected deceleration data points from the accelerogram obtained from the primary impact of the slapdown test (measured at accelerometer 3) are superimposed with the predicted time history. Note that both predicted and measured time histories are filtered with the same cut-off frequency. In addition, the deformed shape of the impact limiters predicted by LS-DYNA, as shown in Figure 4, also matches that shown in the corresponding pictures taken after the slapdown drop test.

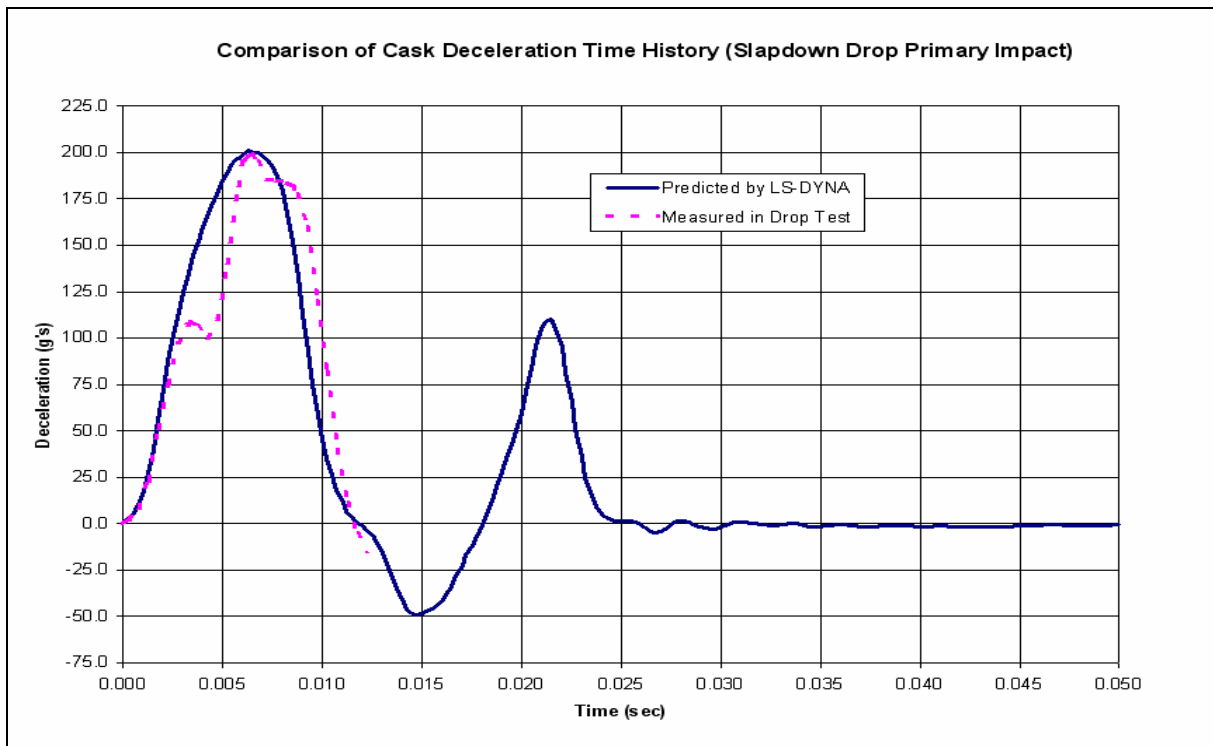

Figure 3: Filtered Deceleration Time History Comparison – Slapdown (Primary Impact)

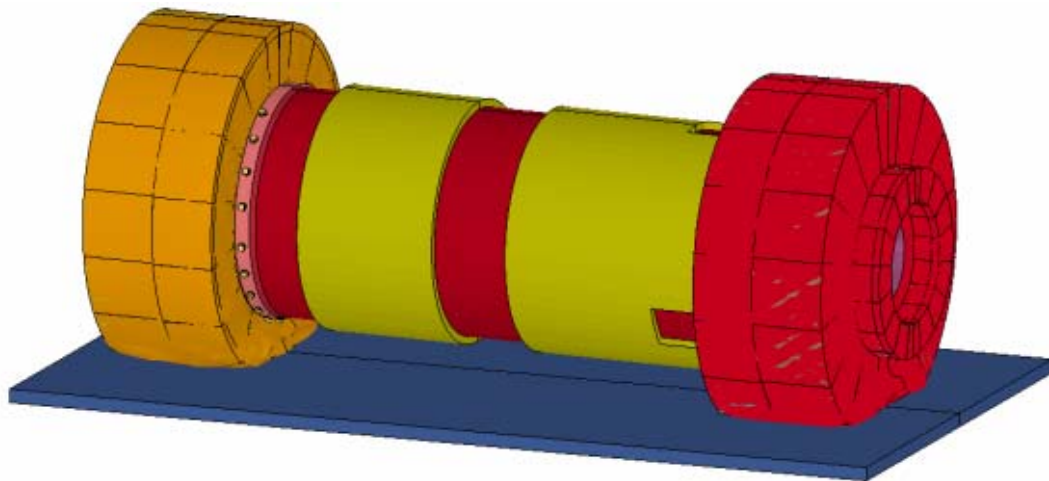

Figure 4: Deformed Shape of Impact Impact limiter after 9-m Slapdown Drop

Finally, LS-DYNA simulations of the ¼-scale drop tests correctly predict the complete shear failure of all bottom impact limiter attachment bolts as shown in Figure 5, which had occurred in the first side drop test. The failure location of the bolt connection predicted by LS-DYNA is also consistent with the photographs taken during the test. For other four successful drop tests, the LS-DYNA simulations predict no attachment bolt failure, which is again consistent with the test results.

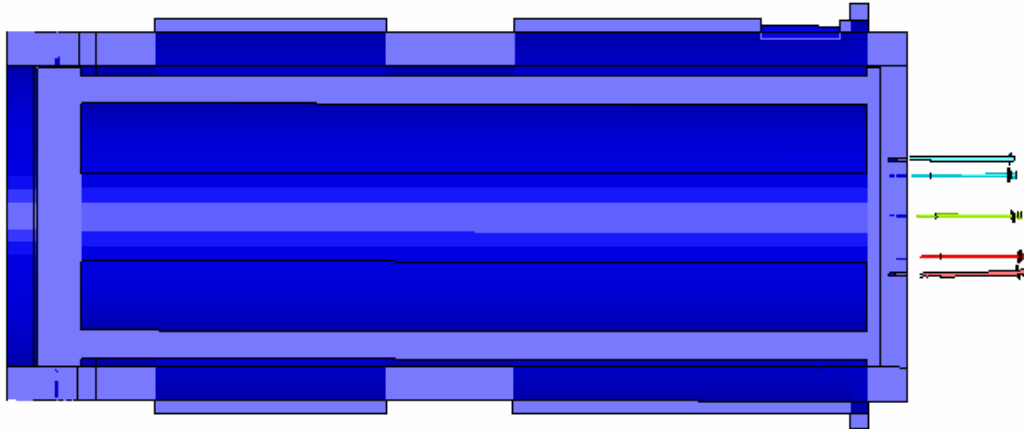

Figure 5: Attachment Bolt Failure Predicted by LS-DYNA for the Initial Side Drop Test

## CONCLUSIONS

Results of the LS-DYNA simulation of the four successful and one unsuccessful AL-STAR scale model drop tests show an excellent agreement with the test data with respect to all key metrics. This successful benchmarking provides a sound technical basis to utilize the benchmarked LS-DYNA model to predict response of all HI-STAR models equipped with AL-STAR impact limiters. The ability of LS-DYNA to simulate the performance of the fasteners in the scale model tests provides the transport package designer the additional ability to peer into the response of the bolted joints and predict their sealworthiness with confidence. In contrary to the “go, no go” result from a physical test, the LS-DYNA analysis provides information on the actual margins such as the margin against bolt failure and gasket decompression. In a broader sense, this paper provides a robust evidence of the ability of a suitably discretized LS-DYNA based FE model to perform accurate structural evaluations of a spent fuel transport package under hypothetical accident conditions.

## REFERENCES

- [1] Title 10, Code of Federal Regulations, Part 71 (10CFR71), “Packaging and Transportation of Radioactive Materials”, 2003.
- [2] Livermore Software Technology Corporation, LS-DYNA Version 971.
- [3] Spent Fuel Project Office Interim Staff Guidance – 21 (IGS-21), “Use of Computational Modeling Software”, April 5, 2006.
- [4] Holtec Report HI-981891, “Impact Limiter Drop Tests Report – Second Series”, Revision 3.
- [5] Holtec Report HI-951251, “HI-STAR 100 SAR”, Revision 12.
- [6] Holtec Report HI-961590, “HI-STAR 100 ¼ Scale Test Model”, Revision 0.
- [7] Holtec Documentation Package No. DOC-5014-1, “Documentation Package for ¼ Scale Impact Limiter Drop Tests”.
- [8] Holtec Position Paper DS-307, “Construction of True-Stress-True-Strain Curve for LS-DYNA Simulations”, Revision 2.