

ANF-18: A New Transport Container for Fresh PWR Fuel Assemblies According to IAEA Requirements

W. Jahreiß
Framatome ANP GmbH
Bunsenstr. 43
D - 91058 Erlangen

U. Philippczyk
Advanced Nuclear Fuels GmbH
Am Seitenkanal 1
D - 49811 Lingen

W. Paulinyi
Advanced Nuclear Fuels GmbH
Am Seitenkanal 1
D - 49811 Lingen

T. Quercetti
Federal Institute for Materials
Research and Testing
Unter den Eichen 87
D - 12205 Berlin

Introduction

The shipment of non-irradiated PWR uranium fuel assemblies (including enriched reprocessed uranium or ERU) from the fabrication facility to power plants will be performed using the new ANF-18 transport container. The ANF-18 container design fully meets the requirements of the IAEA Safety Standards Series, No. TS-R-1 (ST-1, Revised) [1] for transportation by road, rail and sea.

The required tests in accordance with the IAEA standards have already been completed for the ANF-18 transport container. The criticality analyses have been performed, the safety analysis report prepared and approval applied for. It is expected that containers of this design will go into service in the course of 2002.

All drop and fire tests for the ANF-18 container were performed at the test site of the Federal Institute for Materials Research and Testing (BAM) in Lehre, Germany.

Safety Requirements

The IAEA requirements [1], which are binding regulations throughout the world, require evidence for shipping containers for unirradiated fuel assemblies that such containers are capable of withstanding serious accidents without the release of radioactive substances or an unacceptable rise in reactivity. Such evidence can be provided on the basis of analysis, by analogy considerations or by tests on full-scale prototypes or on models. The evidence must essentially involve an imaginary accident sequence consisting of a drop from a height of 9 m onto an unyielding target, a drop onto a circular bar from a height of 1 m and a fire test of 30 minutes duration with a flame temperature of at least 800°C. These tests are preceded by verification that the container can also withstand the stresses from normal transport conditions (stacking test, penetration test and drop test from 1.2 m). The dropping positions of the containers must be chosen so that maximum damage is produced with regard to any effects on criticality safety.

ANF-18 Shipping Container

The ANF-18 shipping container for unirradiated PWR fuel assemblies was developed on the basis of the currently used Type III-E shipping container. The ANF-18 shipping container (Fig. 1) comprises a two-section enclosure (base and cover) and a rigid fuel assembly support (cradle) complete with L-

shaped doors to protect the fuel assemblies against the effects of accidents. The cradle is suspended in the base by means of rubber shock absorbers. The cover and base are bolted together.

The fuel assembly support (reverse T with internal rigid structure) and the hollow-section L-shaped doors form two shafts for accommodating two fuel assemblies. The inside of the shafts are lined with boron austenitic steel plates which are connected to the cradle and the L-shaped doors. The doors, which are opened for loading and unloading are connected to the support structure by means of hinged joints. The doors are locked by means of retaining pins inserted along the center partition (vertical part of T).

The boron steel plates of the fuel assembly support structure are covered with plastic in the areas of the bottom and top-end pieces and spacers to prevent direct contact of the structural components of the fuel assemblies with the boron steel. Furthermore, the plastic padding also reduces the radial clearances between fuel assemblies and the closed shaft.

Bottom-end supports (bolted) and top-end adapters (retaining pins) with integrated clamping bolts located at the top-end adapter, are used to secure the fuel assemblies in their axial position.

The side walls of the hood-type cover are designed as a “sandwich” structure with austenitic steel plates on either side and an aluminum honeycomb structure in between. The head and bottom ends of the cover and the base are also designed as an aluminum “sandwich” structure (with austenitic steel cover) and serve as shock absorbers.

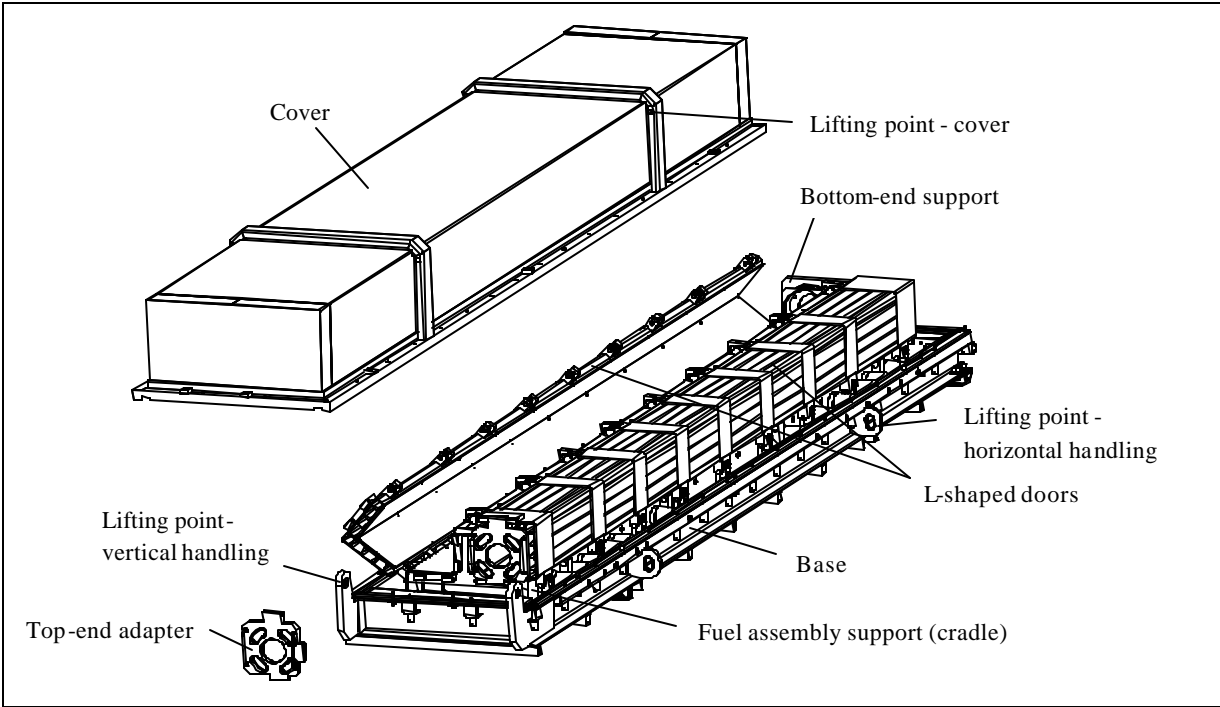

Fig. 1 ANF-18 Shipping Container

The following features characterize the ANF-18 shipping container (Fig. 2):

- IAEA requirements (Safety Standards Series No. TS-R-1), including tests to be performed, are fully met.

- Loading with 5 wt.-% ^{235}U -enriched nuclear fuel with the theoretical pellet density is demonstrated for all PWR fuel assembly designs (14x14 to 18x18 rod array).
- Criticality safety was conservatively demonstrated for a criticality safety index $\text{CSI} = 1$. Up to 50 containers (equivalent to 100 fuel assemblies) can consequently be transported and stored as a unit.
- The proven handling procedures at the power plants are retained. The container can also be handled without the cover.
- In terms of radiation protection, the smooth stainless steel surfaces are easy to survey and, if necessary, also easy to decontaminate.
- The dimensions (5866 mm x 1136 mm x 792 mm) and gross weight (max. 4700 kg) of the loaded shipping container ensure economic transport. A truck with a payload of 25 tonnes can transport 5 shipping containers packed with 10 fuel assemblies.

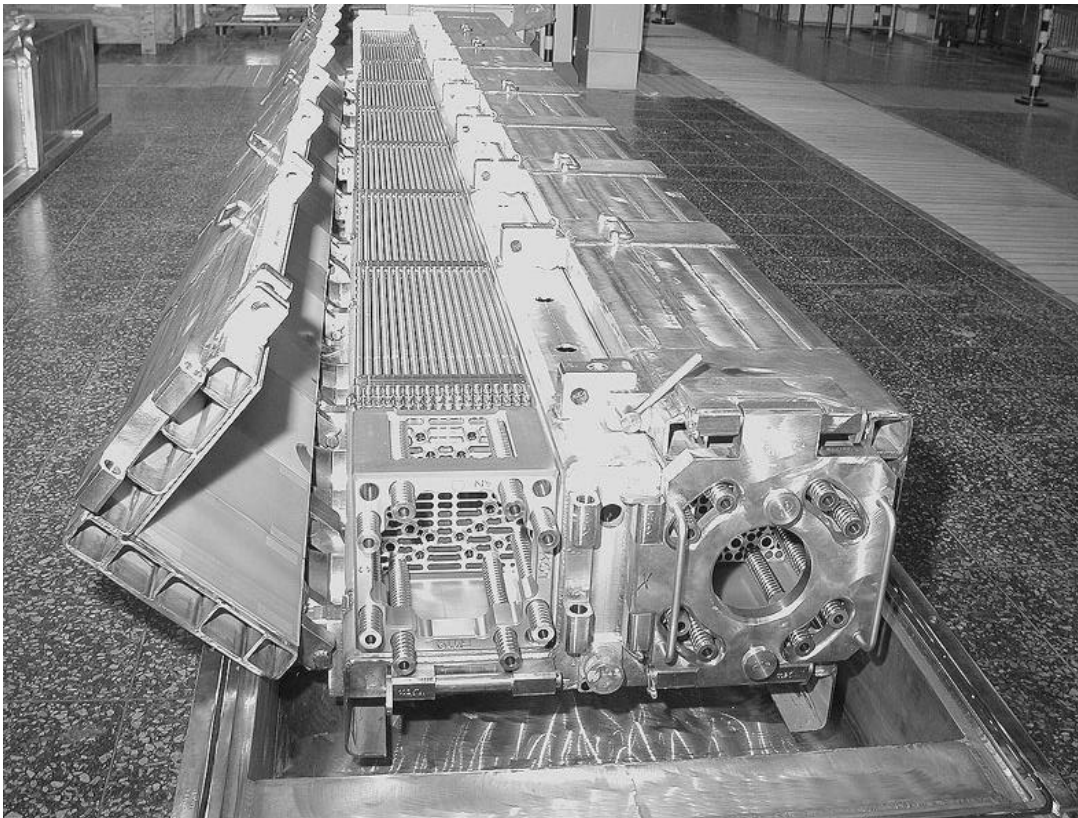

Fig. 2 ANF-18 Shipping Container loaded with Fuel Assemblies

Analytical Investigations

Development of the ANF-18 shipping container was accompanied by structural dynamics investigations using the DYNA-3D FEM code [2].

The computer simulations of drop tests according to IAEA specifications served on one hand to verify the state of development. Thus deficiencies could be detected at an early stage and design improvements could be made. On the other hand, the results of the analyses were used as a basis to identify and substantiate the "most damaging position" required by the IAEA for the drop tests (Fig. 3).

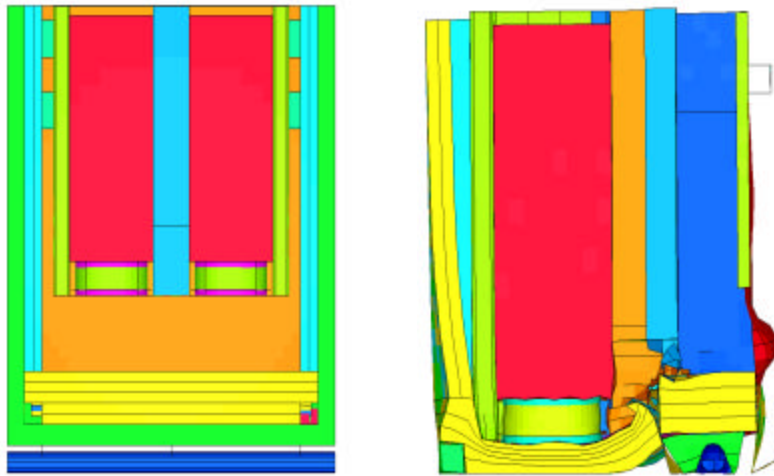

Fig. 3 ANF-18 Computer Simulation of the Vertical Drop Test from a Height of 9 m

Tests for ANF-18 Shipping Container

All mechanical tests detailed below were performed on the same prototype. The container was loaded with two dummy assemblies (16x16 and 18x18 rod array) which were identical to the standard fuel assemblies with the exception of the pellets (uranium dioxide was substituted with lead). The dummy rods were filled with helium at an enveloping pressure and welded leaktight.

During the stacking test, the container was loaded for 24 hours with a weight exceeding five times the weight of a loaded container (25000 kg).

The penetration test was performed by dropping a 6-kg steel bar with a diameter of 3.2 cm onto the side wall of the container from a height of 1.2 m.

The drop-test sequence for the ANF-18 shipping container comprised the following:

- free drop of the container, with a longitudinal inclination of 15°, from a height of 1.3 m onto a side wall,
- free drop of the container, with a longitudinal inclination of 15°, from a height of 9.6 m onto the same side wall,
- dropping the container, with a longitudinal inclination of 25°, from a height of 1.1 m onto the bar (Fig. 4). The bar was targeted to impact the container in line with the center of gravity on the same side as that impacted in the two previous tests.
- dropping the container, with a lateral inclination of 20°, from a height of 1.1 m onto the bar. The bar was targeted to impact the container in line with the center of gravity on the container bottom.

The drop heights, which were increased slightly compared to the IAEA requirements, compensate the maximum gross weight.

Fire-resistance testing of the fuel rods was performed in the laboratory furnace using representative dummy rod sections and with an ANF-18 test segment (shortened model of the full-scale ANF-18) at the BAM facility in Lehre. Figure 5 shows the ANF-18 test segment after the fire test.

The ANF-18 test segment was prepared consistent with the results of the drop test from 1.1 m onto a bar (bottom plate penetrated) and then subjected to a 30-minute fire test at a mean flame temperature

of approximately 900°C. The mean temperature at the surface of the container reached 836°C, while a maximum of 514°C was measured at the fuel rod positions.



Fig. 4 ANF-18 Bar Drop Test from a Height of 1.1 m

The stacking test only produced marginal permanent deformation of the shipping container. The penetration test produced only a local indentation in the outer plate of the container cover. Following the 1.3-m free drop and the 9.6-m free drop tests, the container did exhibit local deformations at the points of impact. Some bolts for the container cover were damaged but the container cover remained securely connected to the base. The 1.1 m-bar drop test onto the side of the container did result in local compression of the “sandwich” structure of the cover and the hollow-sections of the L-shaped doors at this position. The 1.1-m bar drop test onto the bottom of the container resulted in a penetration of the steel plate by the bar.

The dummy rods and the spacers of the dummy assemblies exhibited some deformation, but spacer strips were not fractured. The cross sectional area of the dummy assemblies was not enlarged. Following completion of the drop tests, holes were drilled into all cladding tubes in order to verify that the dummy rods remained leaktight.

The thermal test with the representative dummy rod sections for 14 x 14, 15x15, 16x16, 17x17 and 18x18 rod arrays in the laboratory furnace was performed at 650°C for 60 minutes. The insulating effect of the container was conservatively taken into account. The diameter of the cladding increased by roughly 1 mm. However, no ballooning occurred, and the cladding tubes remained gastight.

The thermal test with the ANF-18 test segment in the fire did not result in any significant deformation of the fuel assembly support or the L-shaped doors. The maximum temperature at the fuel rod positions was 514°C. This demonstrates that the thermal test with the representative dummy rod sections (650°C / 60 minutes) was performed on the basis of very conservative assumptions.



Fig. 5 ANF-18 Test Segment After Fire Test

Criticality Analyses for ANF-18 Shipping Container

Criticality safety was demonstrated for ANF-18 shipping containers loaded with uranium fuel assemblies of the 14 x 14, 15x15, 16x16, 17x17 and 18x18 type using the program system SCALE-4.4a [3]. In every case, a maximum ^{235}U enrichment of 5.05 wt.-% (nominal value plus 0.05 wt.-% tolerance) and a theoretical pellet density of 10.96 g/cm³ were assumed for the nuclear fuel. Neutron poisons capable of being burnt off (e. g. gadolinium) were conservatively ignored.

In the criticality investigations it was shown that, with an enveloping consideration of the effects of the IAEA test sequence with a criticality safety index $\text{CSI} = 1$ (10 x 10 x 1 array of damaged containers), this container meets the relevant IAEA requirements. The design limit $k_{\text{eff}} \leq 0.95$ is fully met.

References

- [1] Regulations for the Safe Transport of Radioactive Material, 1996 Edition (Revised) Safety Standards Series No. TS-R-1 (ST-1, Revised) Requirements, IAEA, Vienna 2000
- [2] DYNA-3D: A Nonlinear, Explicit, Three-Dimensional Finite Element Code for Solid and Structural Mechanics-User Manual, University of California, Lawrence Livermore National Laboratory, UCID Report, UCRL-MA-107254 Rev. 1, 1993
- [3] SCALE 4.4a: Modular Code System for Performing Standardized Computer Analyses for Licensing Evaluation for Workstations and Personal Computers NUREG/CR-0200, Rev. 6; NUREG/CR-6182, Vol. 1; ORNL/NUREG/CSD-2/R6 V. 1-3; ORNL/TM-12663/V1, 2000